



Code: 101504
Original Instructions

Hinge Jig with Clamping Plate



- Contains four adjustable hinge apertures
 - It has six bradawl holes
 - Can be used for hinges between 50mm(2") - 127mm(5") x 6.5mm - 35mm.
- Other Equipment required:-
- 16mm diameter guide bush.
 - Philips screwdriver to adjust hinge apertures.

Engraved marking allows easy hinge measurement and setting.

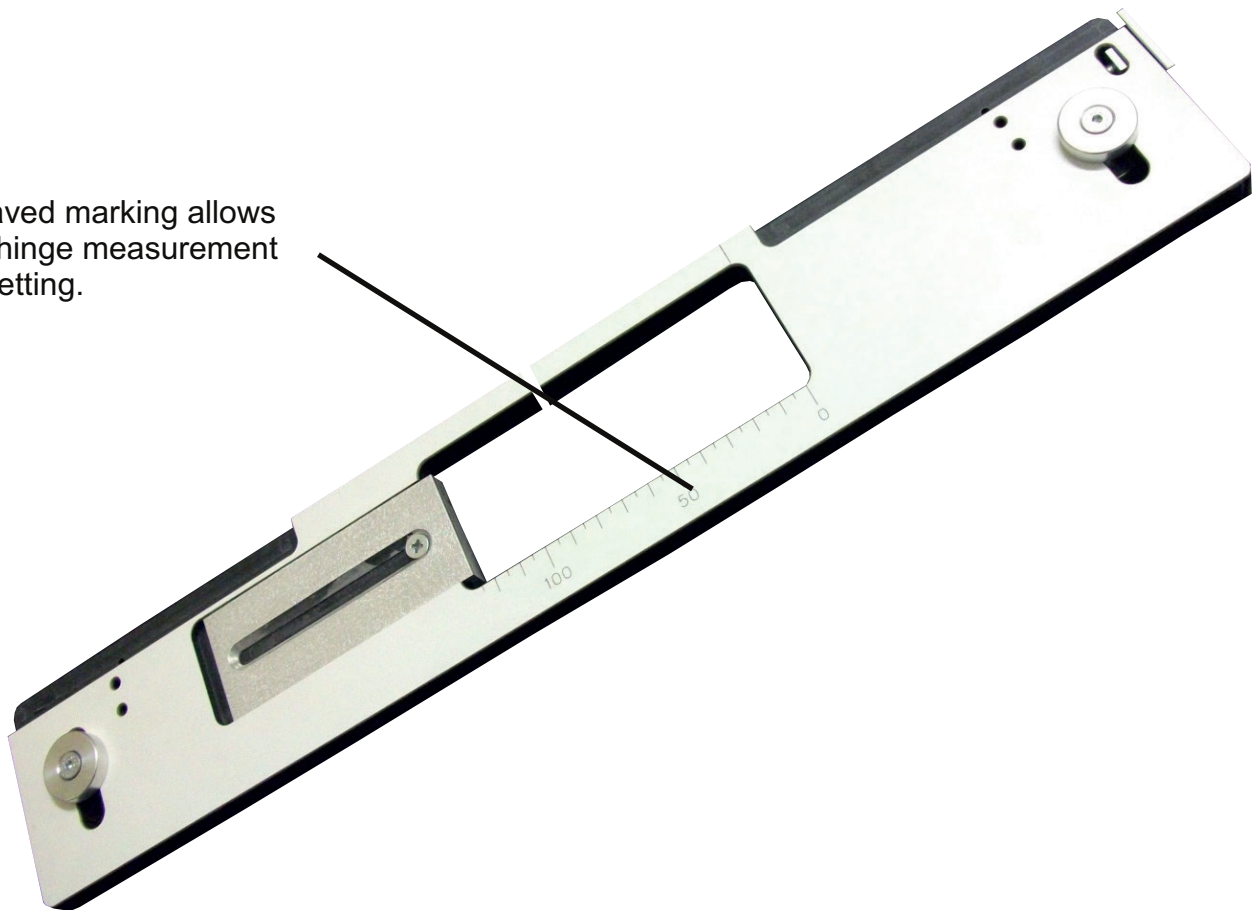

A sliding plate allows hinge length adjustment.

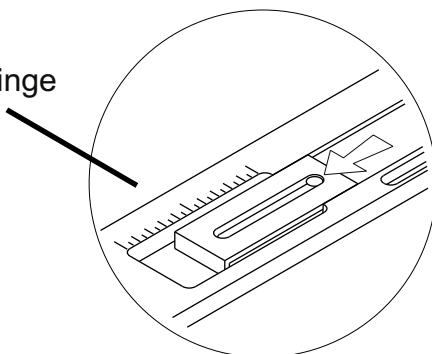

Hinge sizes possible

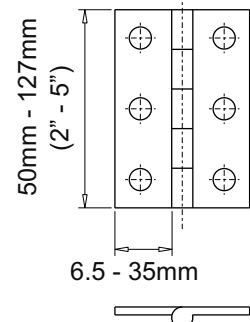

1. Set up the Hinge Length

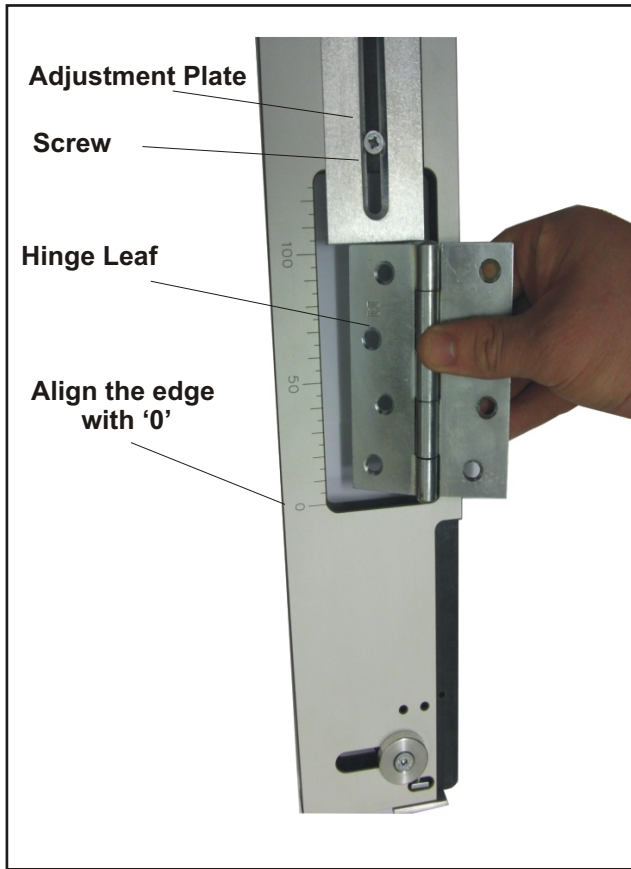

1. Adjust the length of the aperture using the engraved markings.
2. Loosen the screw so that the adjustment plate is free to slide.
3. Align the leaf of the hinge with '0' as shown in the photo left.
4. Slide the adjustment plate so that it touches the edge of the hinge. Tighten the screw to secure the adjustment plate in place.

NOTE: If the length setup was done correctly then the length of the hinge aperture on the jig should be 4mm longer than that of the hinge itself. This is due to the guide bush and cutter offset - please see diagram below.

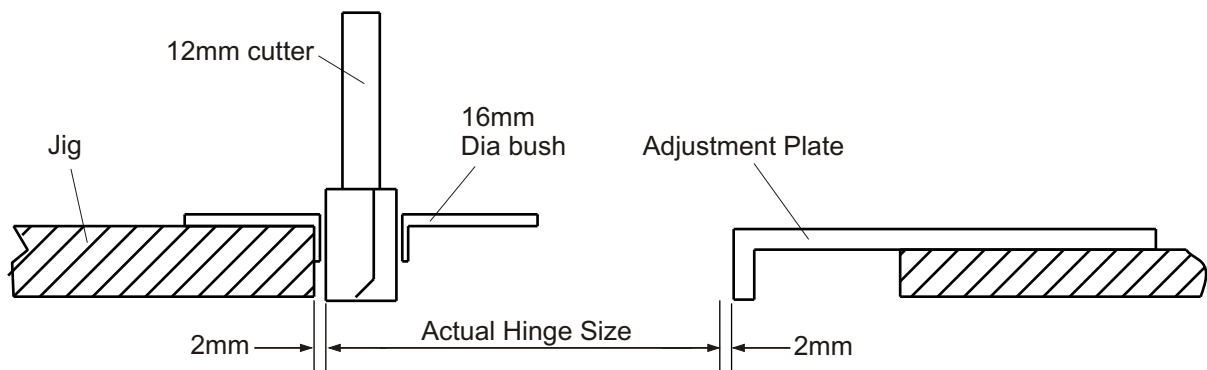

2. Set up the Hinge Depth

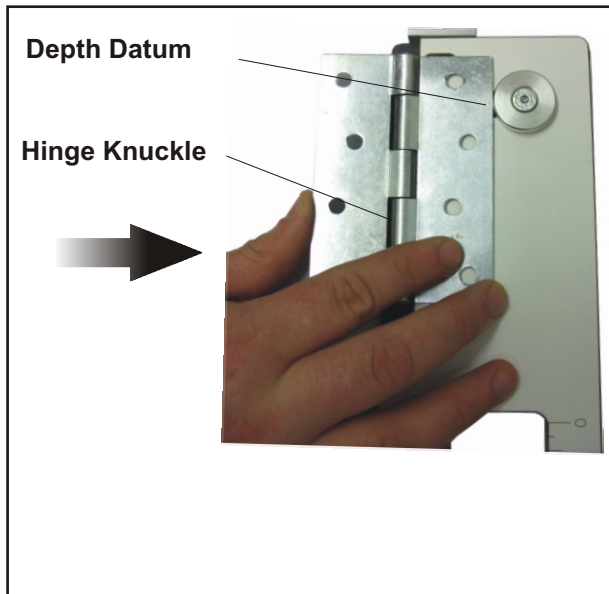

1. Loosen the screw of the depth datum.
2. Place the knuckle of the hinge in the top slot as shown in the diagram, and push in the direction shown.
3. Move the depth datum so it butts up against the edge of the hinge.
4. Tighten the depth datum by hand.
5. Repeat this sequence when using the bottom slot.

3. Rout Hinge Recesses in Door

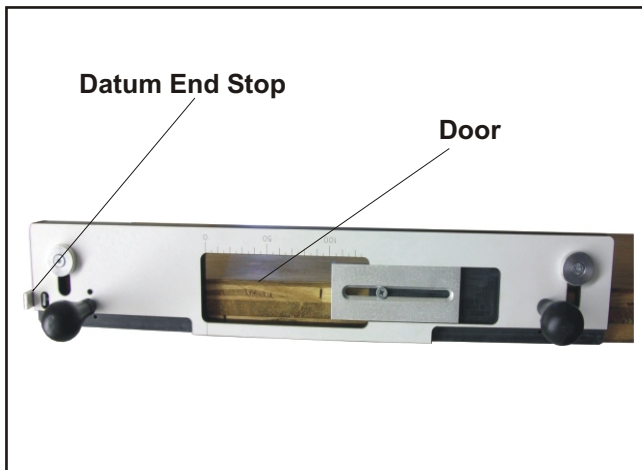

1. Lay the door down on its front edge and secure in position.
2. Loosen the screw securing the datum end stop and rotate 90 degrees - as shown in the photo left.
3. Tighten the screw to secure datum end stop.
4. The end stop hooks over the top of the door and positions the hinges in the correct place. Make sure the end stop is pushed against the top of the door.

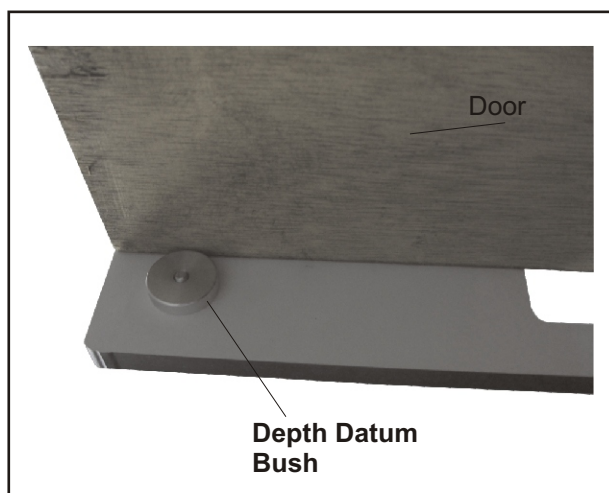

5. Make sure all two depth datum bushes are against the opening face of the door

Rout Hinge Recesses in Door cont...

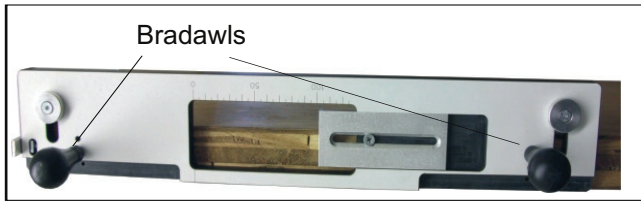

Pic.1

Pic.2

Pic.3

6. Secure the jig to the door with bradawls (not included) or use the clamp plates provided (Pic.1).
7. Set your router to the depth or slightly deeper than the hinge (Pic.2) - refer to your router manual for instructions on how to do this.
8. Continue to rout the apertures into the door.
9. Remove the bradawls and the jig from the door.
- 10 Chisel the corners of the recess to fit the hinge. UJK Corner Chisel (103864) sold separately (Pic.3).

5. Rout Hinge Recesses in Frame

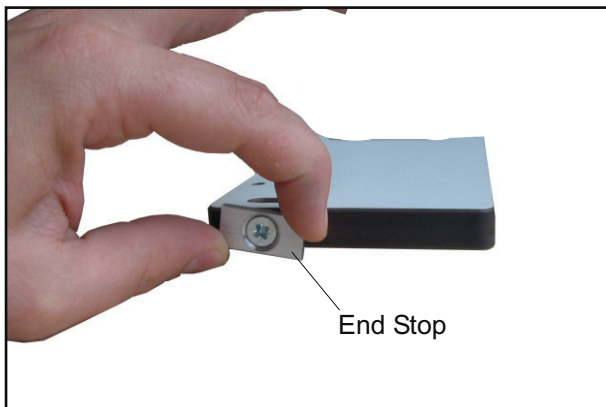

11. Loosen the screw which secures the end stop.
12. Turn the end stop back 90 degrees so that it is in line with the jig. Tighten to secure in place.
13. No further adjustments are needed for the frame.



14. The hinge recesses on the door have to be mirrored onto the frame. To do this, the side which was face up when routing the door, has to be faced against the frame.
15. Butt the jig up inside the frame as shown on the photo left. The end stop will shift the hinge recesses down by 3mm - this will give a 3mm gap between the top of the door and frame.
16. Make sure the depth datum bushes are against the open side of the frame
16. Locate the bradawls.
17. Continue to rout the recesses for the hinges.

USING THE CLAMPING DEVICE

The Clamping Device is designed so that there is no need to use bradawls or screws to secure the jig

IMPORTANT: MAKE SURE YOU POSITION THE CLAMPING DEVICE WITH THE SIDE MARKED (A) FACING TOWARDS THE DOOR/FRAME



1. Use the aluminium bushes (depth datum) to secure the Clamping Device to the jig.
2. Set the hinge depth as explained in page 3 of the instructions.
3. Now the side marked (A) on the Clamping Device will be aligned with the edge of the depth datum

