



Model ATGP-FA-I

T-GLIDE ADVANCE FENCE SYSTEM OWNER'S MANUAL



85-008105-00
Rev A - 05062025

TABLE OF CONTENTS

SAFETY	2
UNPACKING YOUR FENCE SYSTEM	3
INSTALLING THE FENCE RAILS - CABINET SAW	4
INSTALLING THE EXTENSION TABLE, LEGS, AND MAIN TUBE	7
ADJUSTING YOUR FENCE SYSTEM	14
USING YOUR FENCE SYSTEM	17



www.SawStop.eu/support

EN - Additional translations of this manual are available from the above URL.
IT - Ulteriori traduzioni di questo manuale sono disponibili all'URL sopra indicato.
NL - Bijkomende vertalingen van deze handleiding zijn beschikbaar via de bovenstaande URL.
SV - Ytterligare översättningar av denna bruksanvisning är tillgängliga via ovanstående URL.
FI - Oppaan muita käännöksiä on saatavilla yllä olevasta URL-osoitteesta.
DA - Der kan findes yderligere oversættelser af denne vejledning på ovennævnte webadresse.
NB - Ytterligere oversettelser av denne håndboken er tilgjengelige på ovenstående internettadresse.
PT - Traduções adicionais deste manual estão disponíveis no URL acima.
CS - Další překlady tohoto návodu jsou k dispozici na výše uvedené adrese URL.
PL - Dodatkowe tłumaczenia tej instrukcji dostępne są pod powyższym adresem WWW.

Copyright SawStop, LLC
Patents Pending
All Rights Reserved

Original Instructions - T-Glide Advance Fence System

Updates to this manual and additional related documentation such as exploded views and parts lists are available at SawStop.eu or SawStop.uk

SAFETY

1. You **MUST** install a rip fence before using your saw. Using the saw without a rip fence could result in serious personal injury.
2. Never perform a ripping operation freehand or a serious injury may result.
3. Always use a push stick or push block when your hand comes within 6 inches of the blade. Attempting to use the rip fence for narrow cuts without a push stick or push block could result in a serious injury.
4. Do not use the miter gauge when making rip cuts.
5. While making bevel cuts, use the fence only on the right side of the saw blade to prevent the blade from possibly contacting the fence. The brake will activate if the spinning saw blade contacts the metal in the fence.



UNPACKING YOUR FENCE SYSTEM

While unpacking your saw, verify that you have all the components shown below for your specific fence system. Depending on your rip-width capacity needs, the T-Glide Advance Fence System is available with either 36" (910mm) or 52" (1320mm) rails. Although the components pictured below are from the 52" (1320mm) system, the components from the 52" (1320mm) system are nearly identical.

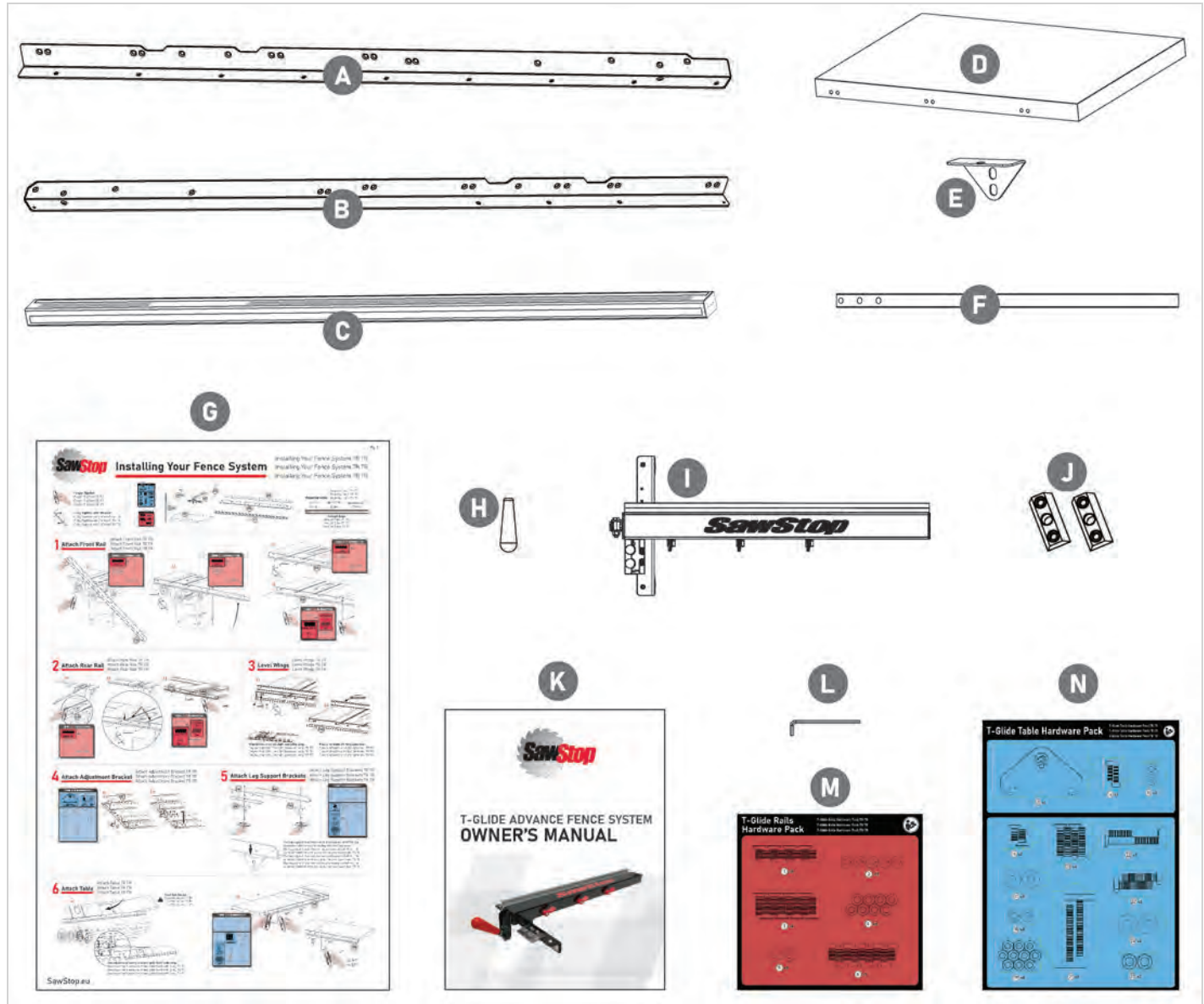

- | | | |
|----------------------------|--------------------------|--------------------------------|
| A. Front Rail | F. Support Leg (2) | K. Owner's Manual |
| B. Rear Rail | G. Assembly Poster | L. 5mm Hex Wrench |
| C. Main Tube | H. Fence Handle | M. T-Glide Rails Hardware Pack |
| D. Extension Table | I. T-Glide Advance Fence | N. T-Glide Table Hardware Pack |
| E. Leg support Bracket (2) | J. Sliding Wedges (2) | |

If any components are missing from your shipment, contact the SawStop Service department for assistance.

INSTALLING THE FENCE RAILS - CABINET SAW

Follow the steps below to install your fence system on a SawStop Professional Cabinet Saw.

NOTE:

Though the illustrations below depict the installation of the 52" (1320mm) fence rail option, the instructions for installation of the 36" (910mm) system are similar. Additionally, the saw model depicted may look slightly different from your saw.

1. Locate the T-Glide Rails Hardware Pack (pictured at right). Begin mounting the front rail (A) (the longer of the two rails) to the front edge of your saw. Center the notches in the rail (X) with the two miter slots (Y) in the table and align the two holes in the rail between the notches with the two corresponding holes in the front edge of the table. Thread an M8 x 16 countersunk socket-head bolt (1) into each hole.

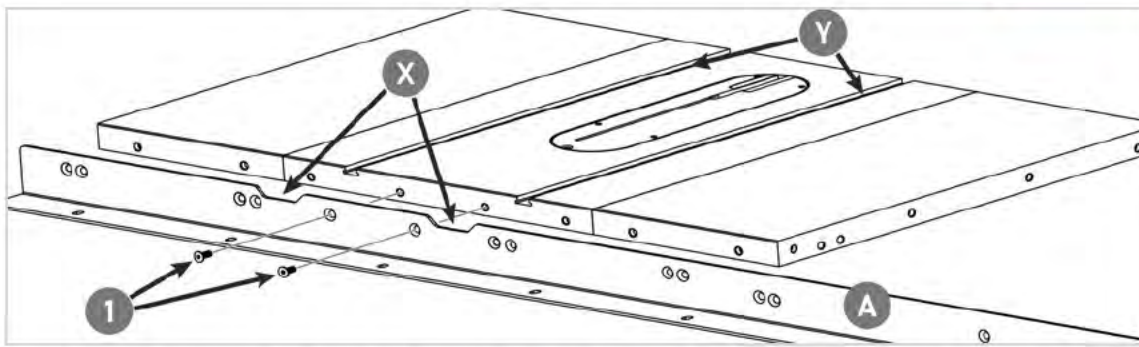

Aligning the two holes between the notches aligns all the other holes used in mounting the rail to your saw. Not all the holes are used to mount the rail to your saw; different holes are used for different saws. Thread the bolts into the corresponding holes, and tighten them using a 5mm hex wrench.

2. Take two more M8 x 16 countersunk socket-head bolts (1) and thread one into the hole to the right of the notches and the other into the hole to the left of the notches. Tighten the bolts with the included 5mm hex wrench.

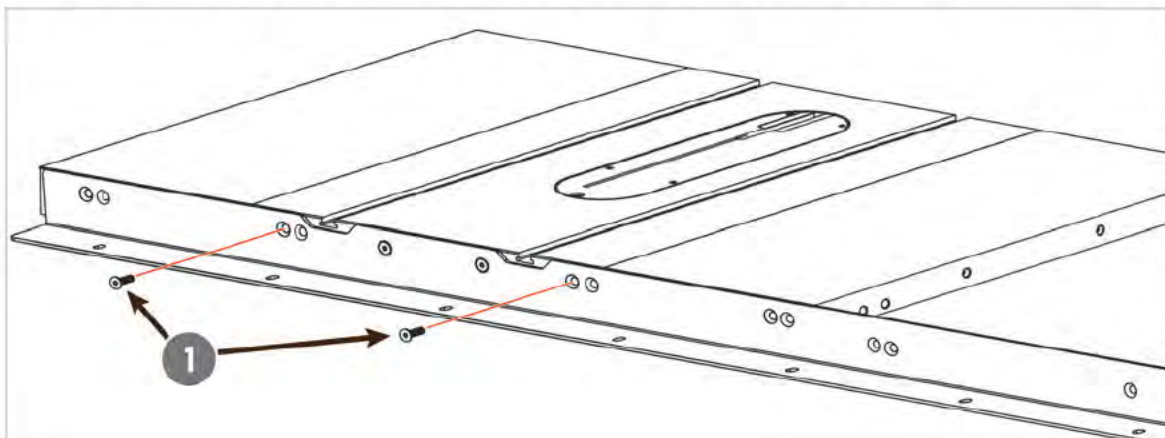

3. Take two M8 x 25 countersunk socket-head bolts (2) and insert one bolt through the corresponding hole in the end of each extension wing. Place an M8 washer (3), an M8 lock washer (4), and an M8 hex nut (5) on the threaded end of each of the bolts. Hand tighten the nuts; do not fully tighten them.

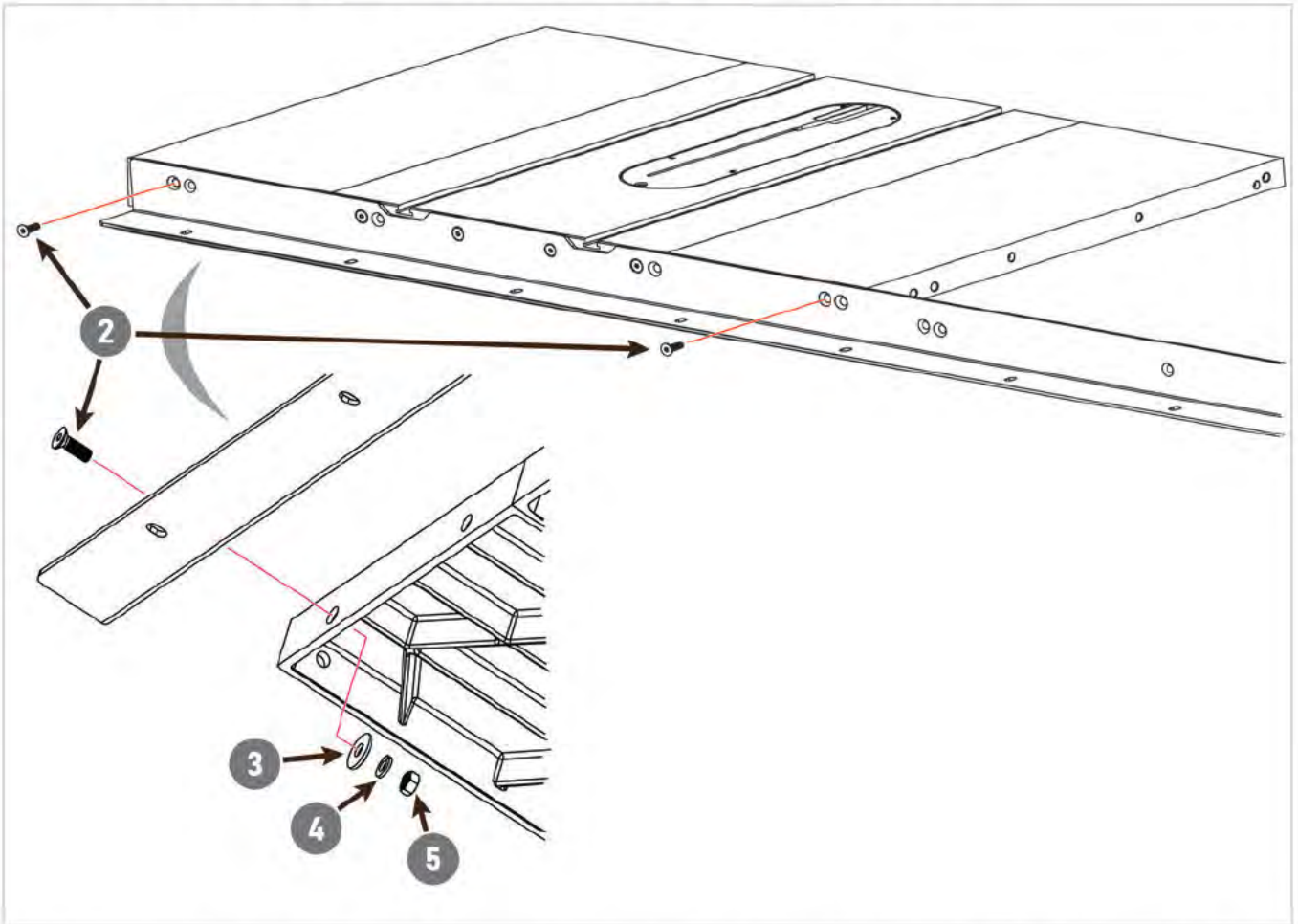

4. Begin mounting the rear rail (B) (the shorter of the two rails) to the rear edge of your saw by centering the notches in the rail (X) with the two miter slots (Y) in the table and aligning the left-most hole between the notches (X) with the corresponding hole in the rear edge of the table.

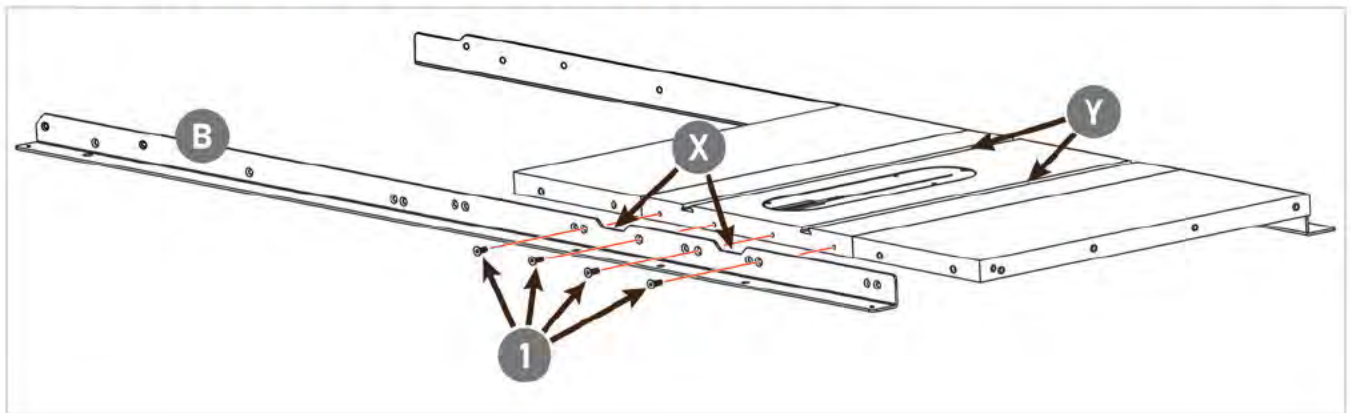

There are three holes in the rail between the notches, one solitary hole and two holes paired together. The left-most hole is the solitary hole. Not all the holes are used to mount the rail to your saw; different holes are used for different saws. Aligning the left-most hole aligns all the other holes used in mounting the rail to your saw. When the holes are aligned, mount the rail to the saw by threading an M8 x 16 countersunk socket-head bolt (1) into each of the four open holes in the rear edge of the table and tighten the bolts using a 5mm hex wrench.

5. Finish mounting the rear rail to your saw by inserting an M8 x 25 countersunk socket-head bolt (2) through the open hole at the end of each extension wing, and placing an M8 washer (3), an M8 lock washer (4), and an M8 hex nut (5) on the threaded end of each bolt. Hand tighten the nuts; do not fully tighten them.

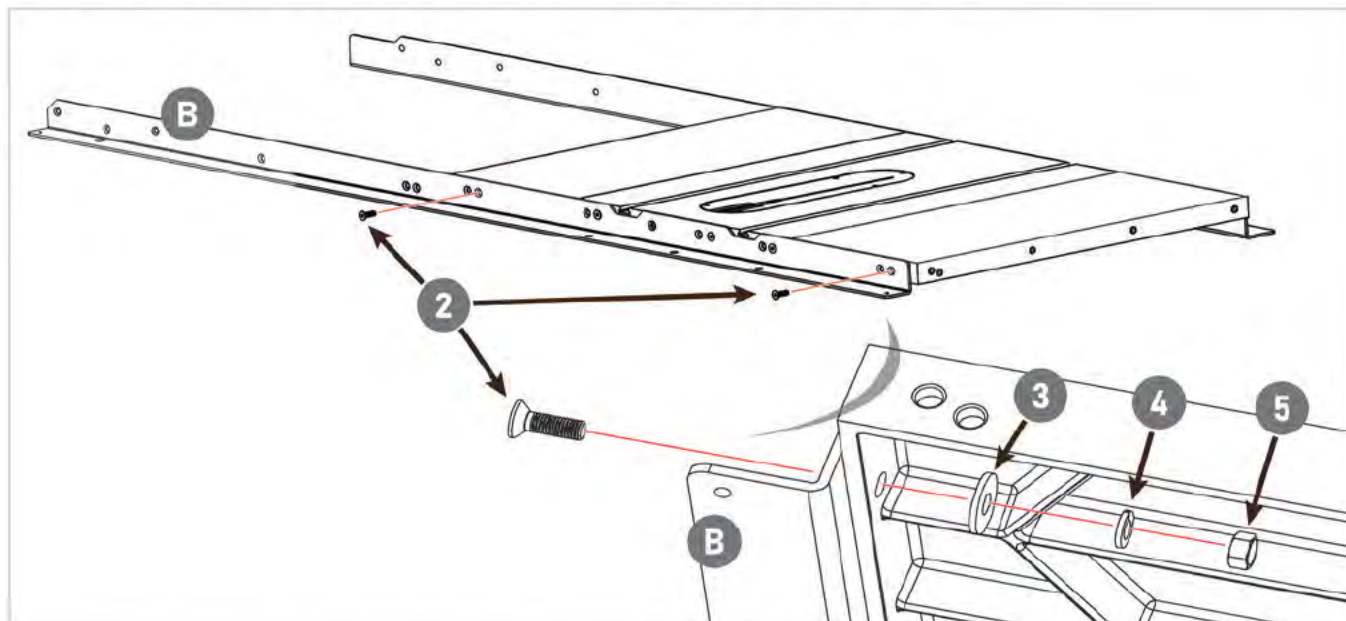

6. Use a straight-edge (Z) to level the front edge of the left extension wing to the cast iron table top. You may have to pull up or push down on the outer edge of the extension wing to level it.

Once the front edge of the left extension wing is level, use the included 5mm hex wrench and a 13mm wrench to fully tighten the nut on the bolt that mounts the left extension wing to the front rail. Repeat this process to level the front edge of the right extension wing and the rear edges of the left and right extension wings.

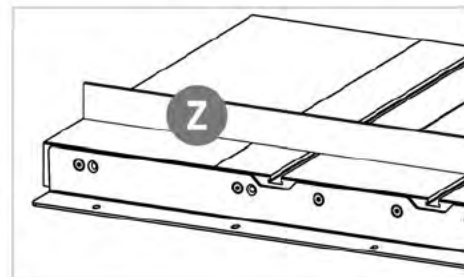

INSTALLING THE EXTENSION TABLE, LEGS, AND MAIN TUBE

1. Remove the adjustment bracket, two M6 x 18 socket cap screws (14), and two M6 lock washers (15) from the T-Glide Table Hardware Pack, and place a lock washer on each screw.

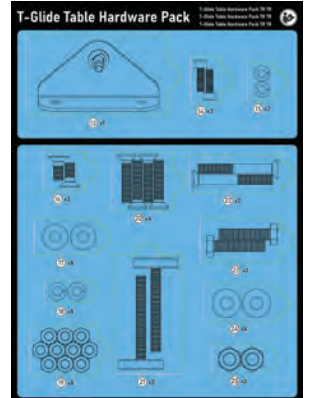

Position the adjustment bracket (13) against the inside edge of the extension table, align the holes, and thread the screws into the holes. Tighten the screws with a 5mm hex wrench.

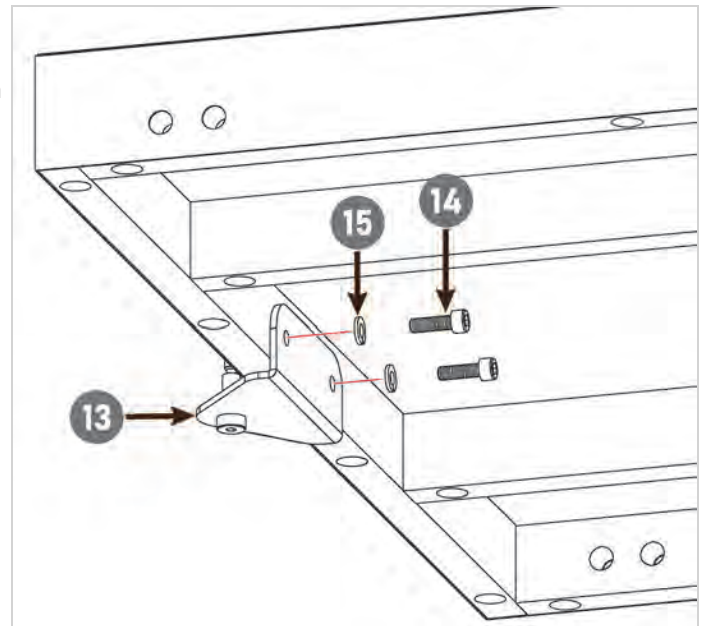

2. Locate the two leg support brackets. Remove the two M8 x 20 countersunk socket-head bolts (16) from the T-Glide Table Hardware Pack (0) along with two M8 washers (17), two M8 lock washers (18) and two M8 hex nuts (19). Mount one leg support bracket to the underside of each of the rails. Hand tighten the nuts; do not fully tighten them.

Once mounted, the brackets should create a shelf as shown below.

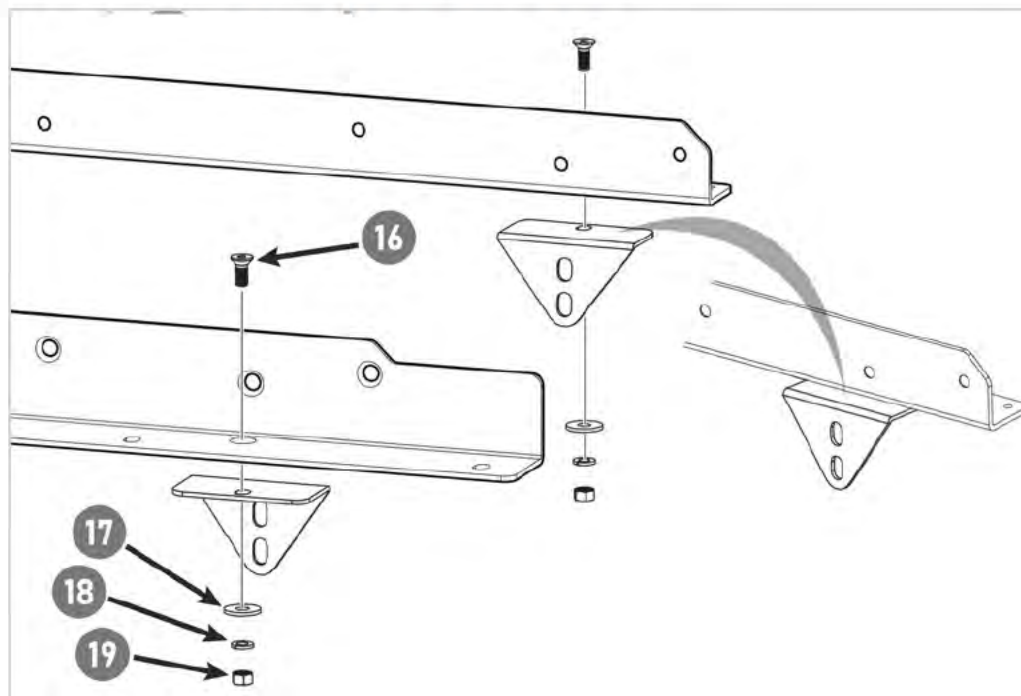

3. Place the extension table between the rails and slide it towards the extension wing. Be careful when positioning the extension table because it is not yet secured to the rails and could fall.



You will need to tilt the extension table slightly for the adjustment bracket to fit under the extension wing. The adjustment bracket includes a screw that extends upward and the underside of the extension wing includes a hole to receive the screw. Fit the screw into the hole, and then turn the screw until the extension table is roughly flush with the extension wing. The opposite end of the extension table will rest upon the leg support brackets but will not be level because the leg support brackets are at different elevations and are not intended to support the extension table once it is fully installed.

- The extension table mounts to the rails with bolts that pass through holes in the rails and extension table as shown.

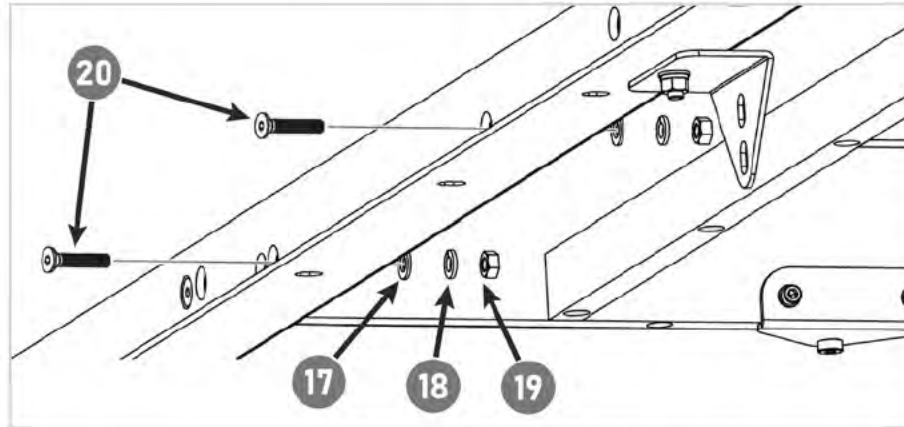

If you have an extension table for a 36" (910mm) fence system, take two M8 x 35 countersunk socket-head bolts (20) and insert one through the hole in the front rail closest to the saw and the other through the hole in the rear rail closest to the saw. If you have an extension table for a 52" (1320mm) fence system, take four M8 x 35 countersunk socket-head bolts (20) and insert one bolt into each of the two holes in the front rail closest to the saw, and one bolt into each of the two holes in the rear rail closest to the saw.

Place an M8 washer (17), an M8 lock washer (18), and an M8 hex nut (19) on the threaded end of each bolt and hand tighten the nuts. Do not insert bolts through the outermost holes in the front and rear rails at this time.

- Locate the two support legs and remove the two feet from the T-Glide Table Hardware Pack along with two M8 hex nuts. Thread an M8 hex nut onto the threaded shaft of each foot so that the nut is close to the rubber base, and then thread the foot into the bottom of the support leg as far as possible.

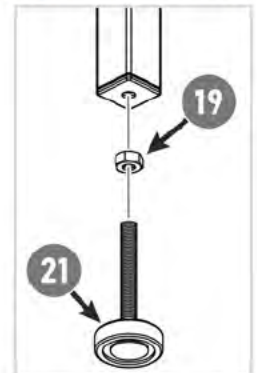

- The support legs attach to the outer ends of the rails and extension table with M8 x 65 countersunk socket-head bolts (22). Align the top hole in one support leg with the outermost hole in the front rail, and the top hole in the second support leg with the outermost hole in the back rail. Make sure the legs are positioned against the inside of the extension table. Insert an M8 x 65 (22) bolt through the holes in the rails, extension table and legs. Place an M8 washer (17) and an M8 lock washer (18) on the threaded end of each bolt and then thread an M8 hex nut (19) onto each bolt. Hand tighten the nuts; do not fully tighten them.

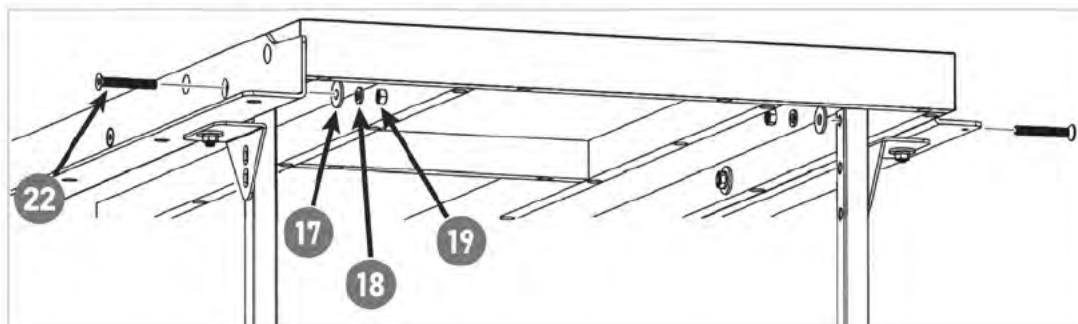

- Attach each support leg to the corresponding leg support bracket with an M10 x 40 hex head bolt (23), two M10 washers (24), and an M10 lock nut (25) as shown. Fully tighten the bolts using two 17 mm wrenches.

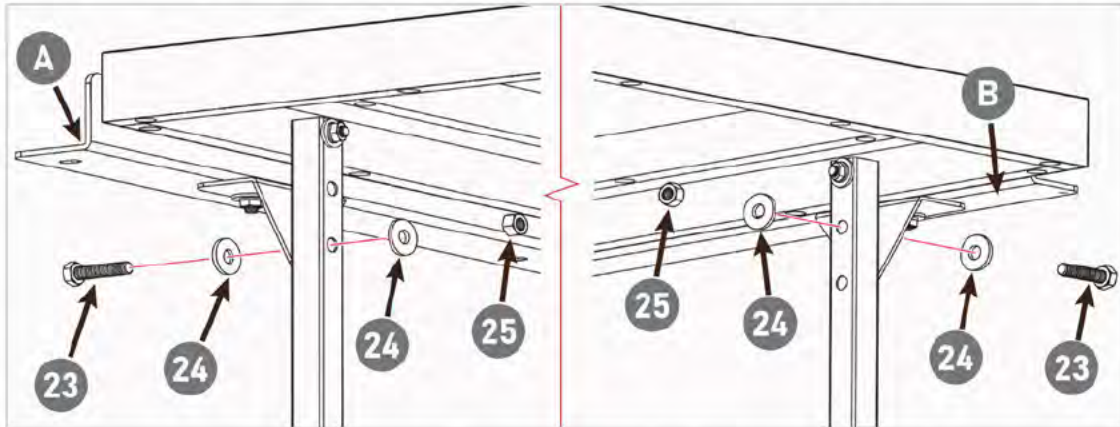

Note that the leg support brackets align with different holes in the front (A) and rear (B) legs because the brackets are at different elevations.

- Use a straight-edge to level the front edge of the extension table to the saw table. You may have to pull up or push down on the extension table to level it. Once the front edge of the extension table is level, use a 5 mm hex wrench and a 13 mm wrench to fully tighten the nuts on the bolts along the front rail. Repeat the process to level the rear edge of the extension table. Also fully tighten the bolts (16) you installed during step 2 that attach the leg support brackets to the front and rear rails.
- Place the straight-edge lengthwise across the middle of the table and level the middle of the extension table. Using a 5mm hex wrench, turning the screw in the adjustment bracket (15) you installed in step 2, rotate the adjustment screw clockwise to raise the center of the adjustment table or counter-clockwise to lower.
- Turn the foot (21) on the bottom of each support leg you assembled in step 5 to adjust its position until it is in solid contact with the ground. Once the foot is in contact with the ground, fully tighten the hex nut (19) against the bottom of the leg using a 13mm wrench.
- Locate the main tube and the T-Glide Rails Hardware Pack. If you have a 36" (910mm) fence system, remove seven M8 x 16 hex head bolts (6) and seven M8 lock washers (4) from the T-Glide Rails Hardware Pack. If you have a 52" (1320mm) fence system, remove nine M8 x 16 hex head (6) bolts and nine M8 lock washers (4) from the T-Glide Rails Hardware Pack.

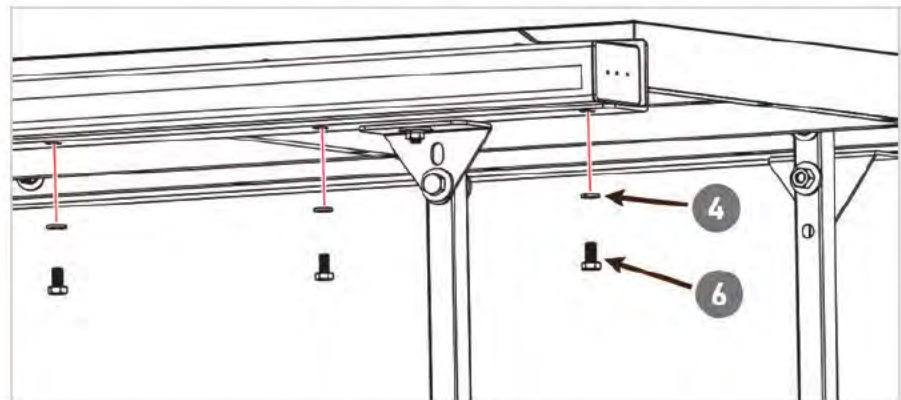
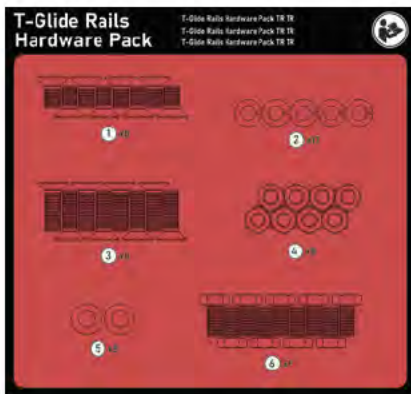

Position the tube on the front rail with the rulers facing up and the 12-inch ruler on the left. The powder coated surfaces of the tube and rail can be slick, so be careful that the tube does not fall off the rail. Align the holes in the rail with the holes in the bottom of the tube. Place an M8 lock washer (4) on each M8 x 16 hex head bolt (6)

and insert the bolts through the rail and into the threaded holes in the bottom of the tube. Hand tighten the bolts; do not fully tighten them.

SET LOCKING FORCE AND ALIGN MAIN TUBE

1. Locate the fence and the red fence handle (H). Thread the handle into the cam lock on the front of the fence.

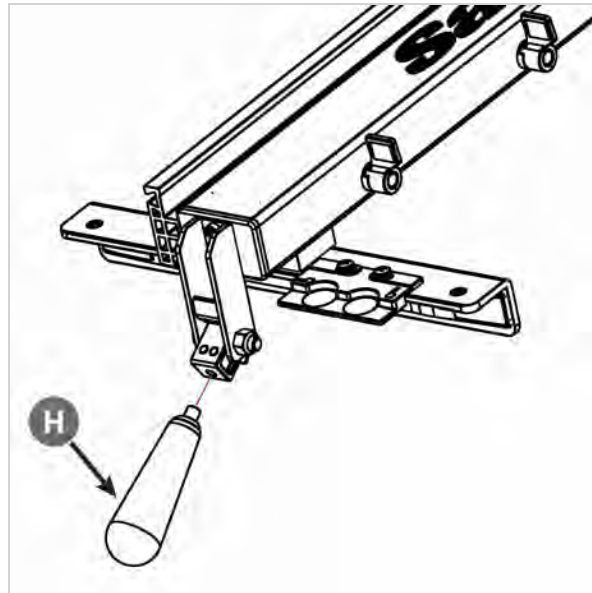

2. The holes in the bottom of the front rail are oversized to allow you to adjust the position of the main tube (C) on the rail. To set the main tube in the correct position, first pull the main tube (C) away from the table as far as possible. Next, place your fence (I) down on the tube near the left end.

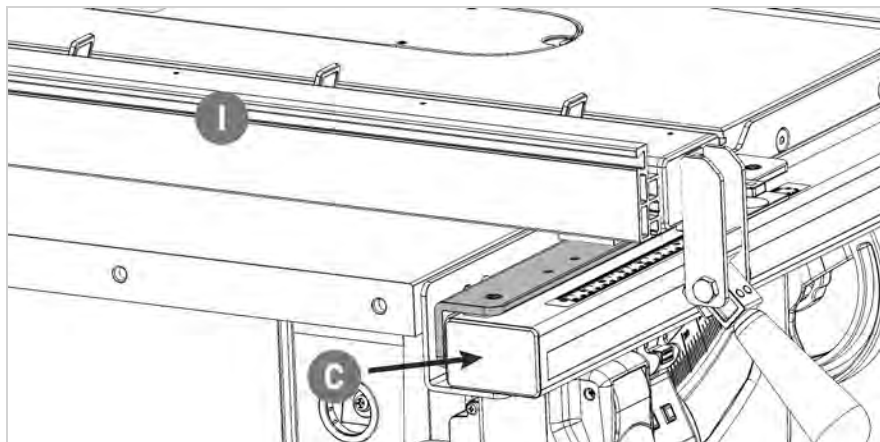

3. Press down on the red fence handle to clamp the fence to the front tube. If the fence does not clamp tightly enough to hold its position against a moderate amount of force, you can increase the clamping pressure by turning both parallelism adjustment screws (X) clockwise using a 5mm hex wrench. Be sure to turn both screws an equal amount. Those screws are located in the vertical portion of the fence cross-bracket.

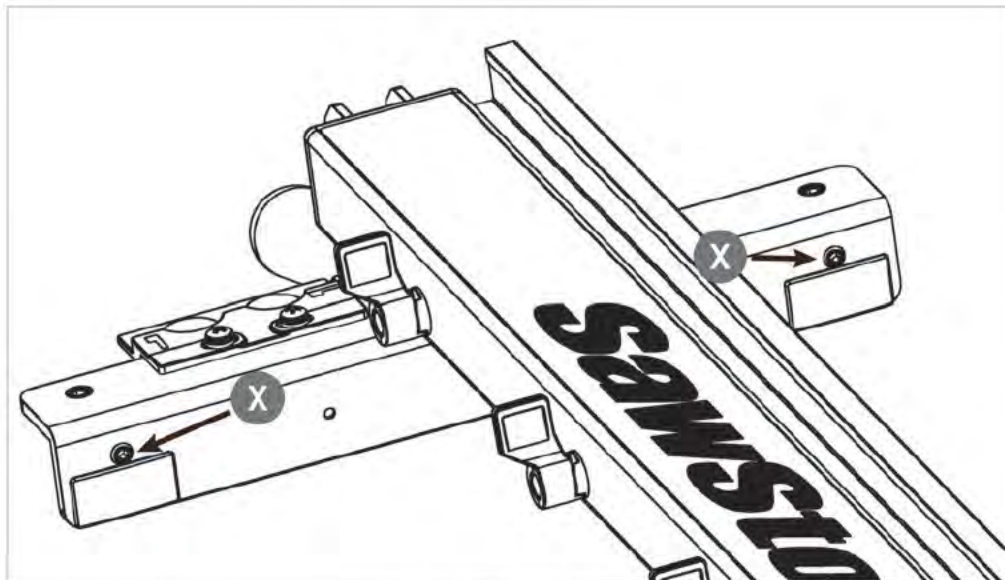

Alternatively, if too much force is required to push the fence handle down to clamp the fence to the front tube, you can reduce the clamping pressure by turning both parallelism adjustment screws (X) counter-clockwise. Be sure to turn both screws an equal amount.

4. Once the fence is tightly clamped to the front tube, move the left end of the tube toward the saw until there is only a small gap (approximately 1/32 inch or 0.8mm) between the front rail and the rear of the fence. (Consider stacking up a few playing cards to serve as a spacer.)

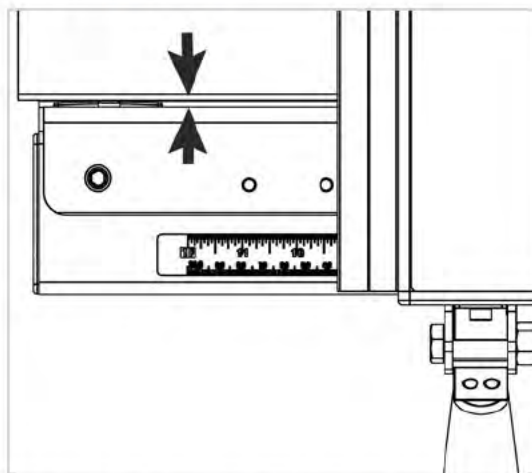

Tighten the left-most M8 x 16 hex head bolt that holds the tube to the front rail using a 13 mm wrench.

5. Next, move the fence to the right end of the tube, repeat the above process to position the tube, and tighten the right-most screw. Once both ends of the tube are adjusted correctly, tighten the remaining M8 x 16 hex head bolts to mount the front tube to the front rail.

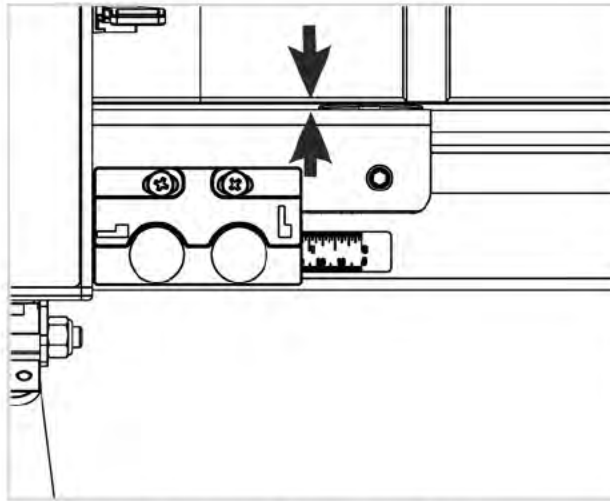

The fence should now slide smoothly along the front tube without binding and without excessive play.

Congragatulations! Your fence system is now assembled.

ADJUSTING YOUR FENCE SYSTEM

Although the fence is factory-adjusted to nominal settings, it is usually necessary to make final adjustments once your rails and extension table have been installed on the saw.

The fence allows you to precisely set the width of your rip cuts. The precise width of cut is shown by the cursor indicator lens on the front of the fence.

- Read the measurement from this lens when the adjustable fence face is installed in the high fence (vertical) position.
- Read the measurement from this lens when the adjustable fence face is installed in the low fence (horizontal) orientation. For more information about the low fence feature, see page 20.

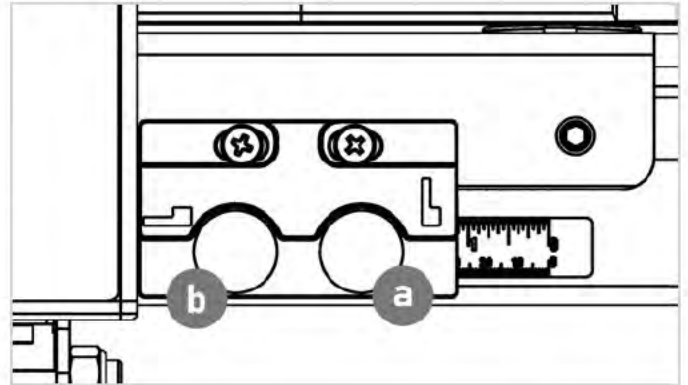

If necessary, you can adjust the position of the indicator lenses on the front of the fence. To verify the position of each indicator lens, clamp the fence to the front tube and use a ruler to measure the distance from the blade to the fence plate and compare it to the measurement shown on the proper indicator lens. If adjustment is necessary, loosen the two Phillips screws indicated below and slide the indicator lens to the right or left until the cursor is directly over the correct measurement. Tighten the screws to secure the position of the indicator lens.

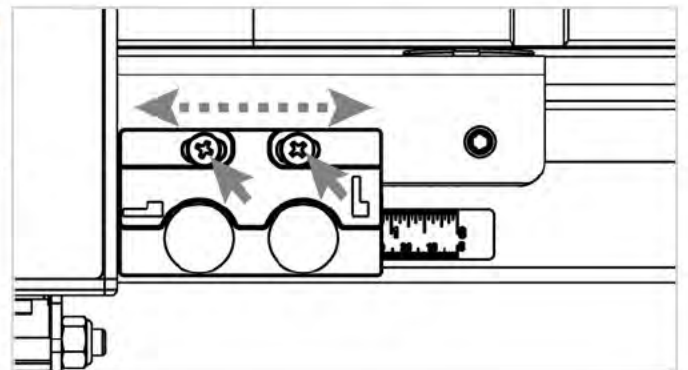

NOTE:

If needed, the lens can be removed and relocated to the opposite side of the main fence tube when the fence is used on the left side of the blade. For detailed instructions see **REVERSING THE FENCE** on page 21.

The next step is to align the face plates to be parallel to the miter slots. Begin by sliding the fence along the front tube until the left face plate is flush with the right edge of the right miter slot. Lock the fence handle and check that the face plate is flush with the miter slot edge along its whole length. You can check this either visually or by running your finger along the face plate and miter slot edge.

If there is any misalignment, you can correct it by turning one of the two parallelism adjustment screws in the vertical edge of the fence cross-bracket (see step 3 instructions on page 11).

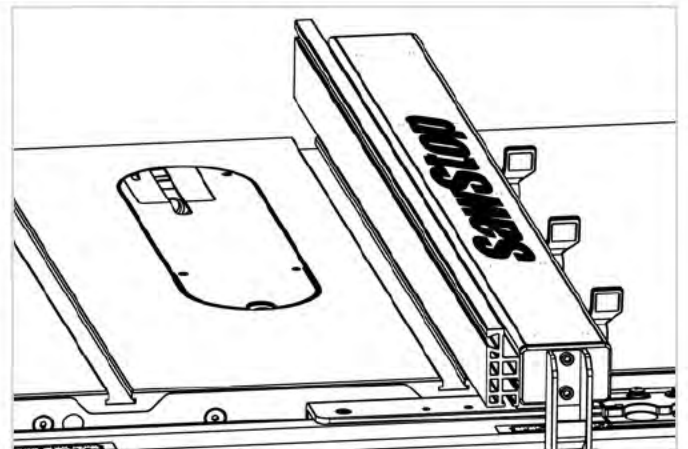

Next, adjust the face of the fence to be perpendicular to the table top. The angle between the face and the table is set by the two plastic leveling screws in the horizontal portion of the cross-bracket.

To adjust the angle of the face plate, confirm the fence is not locked in place by lifting the large red handle upward. Also, confirm that the adjustable fence face is secure by setting the three red locking levers to the locked position.

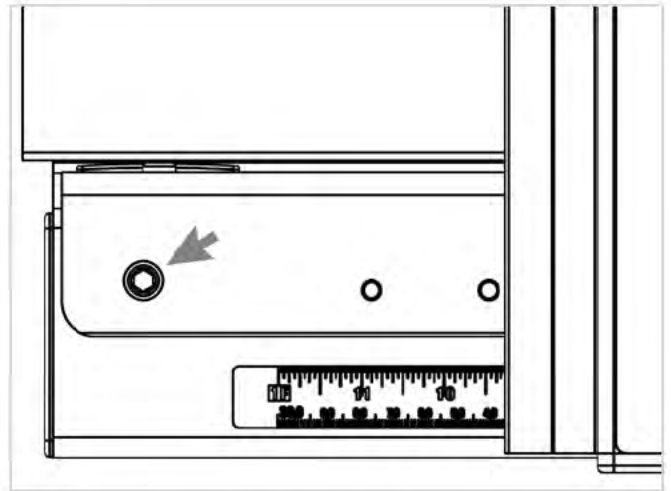

Next, place a square on the table top and against the aluminum adjustable fence face. Use a 6 mm hex wrench to adjust the leveling screws as necessary until the face plate is parallel to the vertical blade of the square.

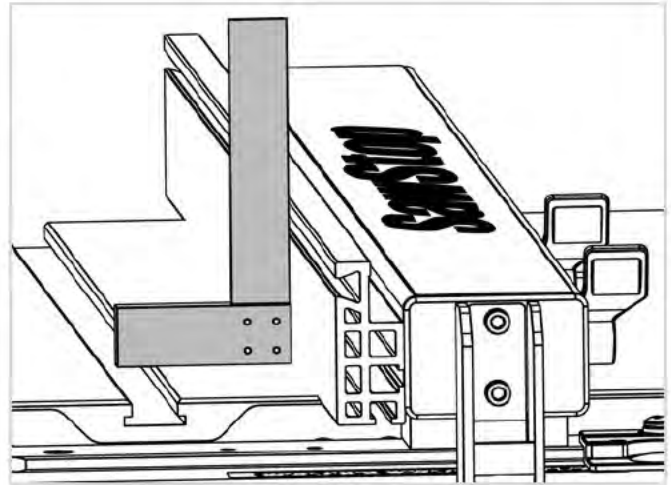

i NOTE:

You may find that after adjusting the face plate the end of the cross-bracket has been raised or lowered such that it is too close or too far away from the main tube. If this is the case, turn both plastic leveling screws the same amount in order to ensure the position indicator lenses are close to, but not touching, the front tube or rulers.

ADJUSTING THE LOCKING LEVERS

Adjusting the clamping force may be needed if one of the levers doesn't provide enough friction when in the locked position or doesn't disengage to allow the adjustable fence face to slide freely when in the unlocked position. The locking levers used to secure the adjustable fence face require a few degrees of rotation to lock or unlock the fence face. The clamping force of these levers is properly set at the factory so it is unlikely that any adjustment is required. Should you wish to change the clamping force of one or more of the locking levers, follow the instructions below.

1. Move all three locking levers (d) to the unlocked position by rotating them counter-clockwise then remove the adjustable fence face (e) from the main fence body.

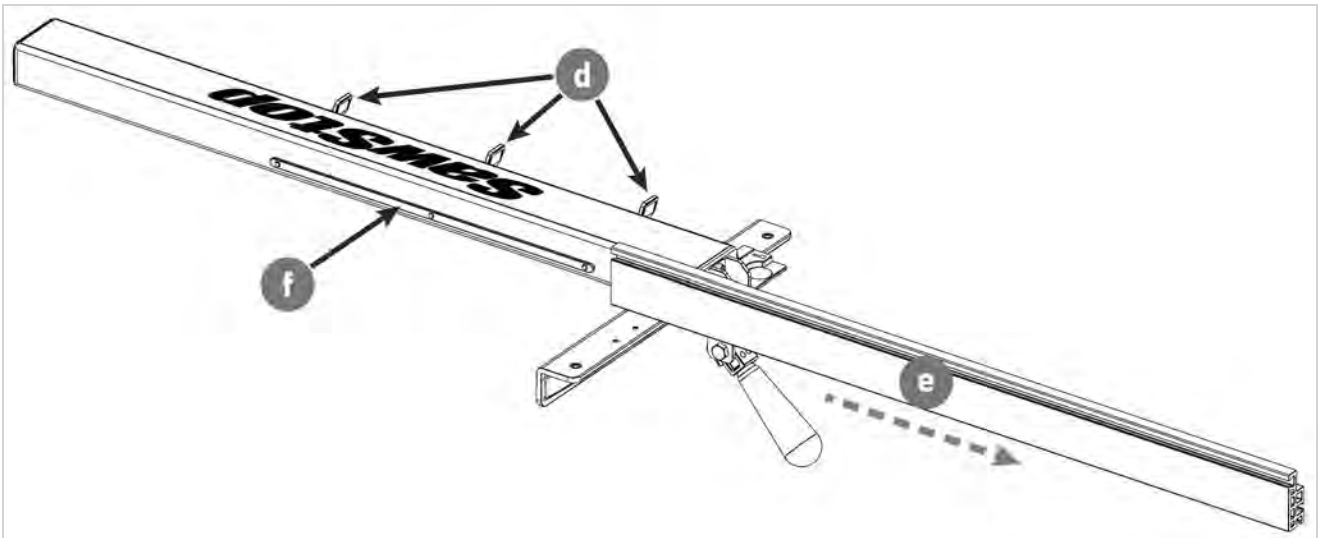

2. Immediately opposite of the locking knob that needs to be adjusted, press the locking bar (f) flush to the main fence body while simultaneously pressing the locking knob against the fence body. Note the hex bolt head that is now exposed.

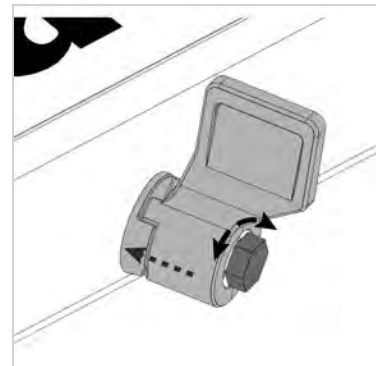

3. To increase the clamping force of this locking knob, rotate the hex bolt clockwise a small amount. To decrease the clamping force of this locking knob, rotate the hex bolt counter-clockwise a small amount.
4. Reassemble the adjustable fence face (e) onto the main fence body and test your adjustment. Repeat the above steps until sufficient clamping force is achieved.

Congratulations! Your fence system is now installed, adjusted and ready to use.

USING YOUR FENCE SYSTEM

GENERAL INSTRUCTIONS

1. To use the rip fence (I), lift the red handle up to the unlocked position and place it on the table so that the fence bracket is resting on the upper rear edge of the front tube (C). You can use the fence on either the left or right side of the blade for non-bevel cuts. If you plan to make bevel cuts, use the fence only on the right side to prevent the blade from possibly contacting the fence.

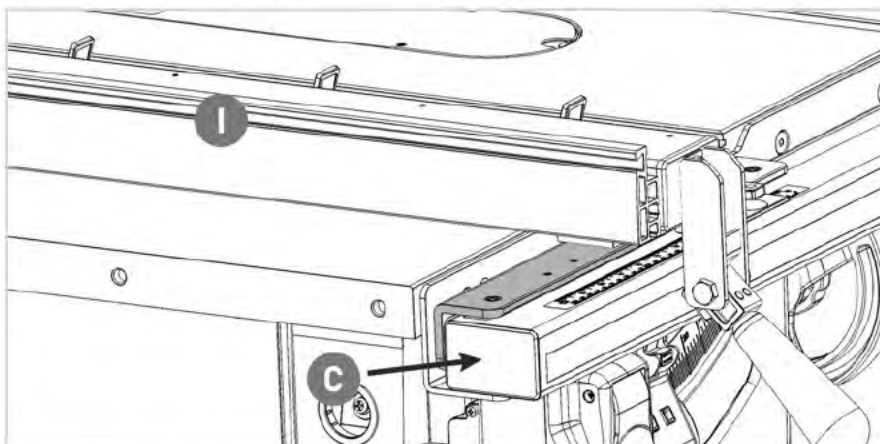

2. Slide the fence to the left or right until the distance between the blade and the fence is approximately equal to the desired width of cut. Be mindful of pinch points when adjusting and locking the fence position.
3. Adjust the position of the fence until the cursor on the indicator lens is directly over the desired width of the cut.

NOTE:

The adjustable, aluminum face of the SawStop T-Glide Advance Fence is designed to be removed from the main fence body and re-installed on the opposite side of the fence body if needed. When using the fence, the adjustable face must be installed so that it is facing the blade. For instructions on this aspect of setting up your fence, see **REVERSING THE FENCE** on page 21.

4. Once the fence is in the correct position, push the red locking handle down to the locked position. The fence is now locked in place and ready for use.

RIP CUTS AND CROSS CUTS

Use the following instructions for setting up your SawStop T-Glide Advance Fence for rip cuts and cross cuts. For more details regarding rip cuts, cross cuts and several other cut types, please read the **Safety and General Use Instructions for Table Saws** manual included with your saw or found online at SawStop.eu.

WARNING:

Maintain a minimum clearance of 1/8" (3mm) between fence and blade. Do not contact the rip fence with the spinning blade as it contains conductive materials. Contact will activate the safety system. When making narrow cuts, employing a low fence can help. (See **USING THE LOW FENCE** on page 20.)

Ripping

It is critical that you use the rip fence when making rip cuts. Never cut any workpiece freehand. Doing so can cause the workpiece to bind which can result in kickback. Learn more about safety and kickback prevention in the **Safety and General Use Instructions for Table Saws** manual included with your saw or found online at SawStop.eu.

For rip cutting, perform the following steps:

1. Position the fence along the ruler at the desired width of cut and lock it in place.
2. Set the blade height. For safety, position the blade just a small amount above the thickness of the workpiece.
3. Open the three locking levers on the side of the main fence body to release the sliding fence face. Rotate the locking levers counter-clockwise.

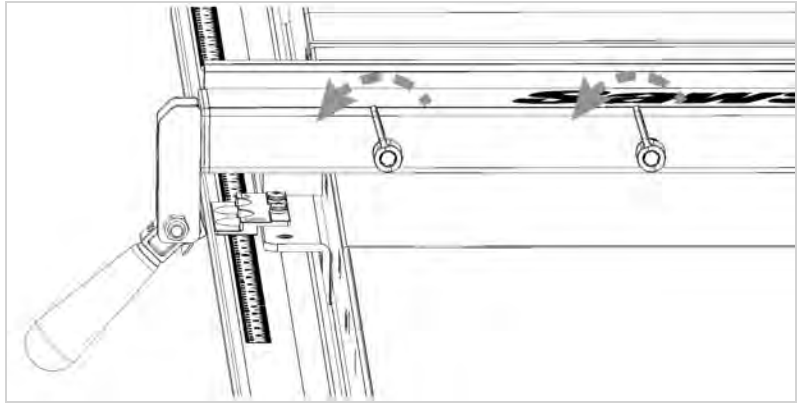

4. The front end of the adjustable fence face (e) should be positioned at an imaginary line at 45° on the table from the front end of the saw blade (s).

This position provides added support to align the workpiece prior to contact with the blade while simultaneously minimizing the potential for kickback.

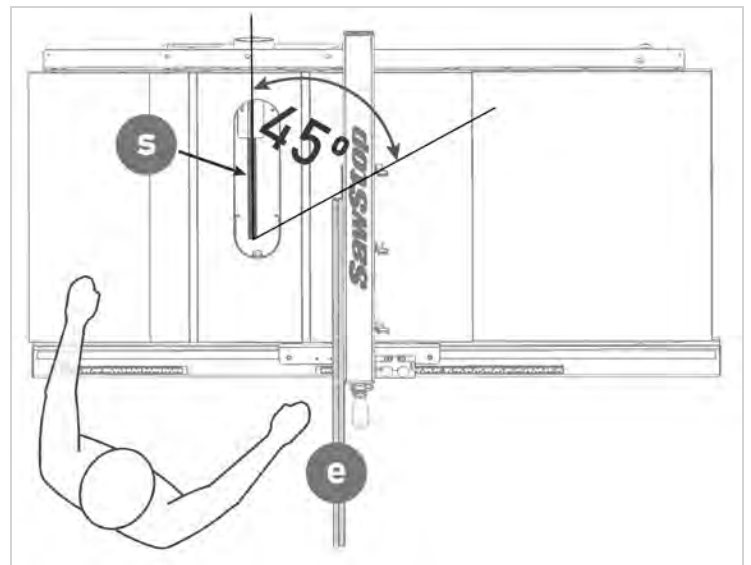

5. Lock the adjustable face in place by closing the lock levers you opened in step 3. Rotate the locking levers clockwise.
6. Position the workpiece flat on the table and flush against the rip fence. When cutting long material, ensure adequate support so the workpiece does not move or shift as it moves past the edge of the table.
7. With the power switch on, pull the Start/Stop paddle to spin the blade.
8. Hold the workpiece squarely and firmly against the rip fence face and table. Push the workpiece slowly and smoothly toward and past the blade.

Cross-cutting

Cross cutting (cutting perpendicular to the grain of the wood) is primarily performed with the miter gauge and crosscut fence included with your saw to move the workpiece past the blade. Optionally, your SawStop T-Glide Advance Fence can also play a role to help achieve safe and accurate cross-cuts by following the steps below.

1. Position the fence along the ruler at the desired length of cut and lock it in place.
2. Set the blade height. For safety, position the blade just a small amount above the thickness of the workpiece.
3. Open the three locking levers on the side of the main fence body to release the sliding fence face. Rotate the locking levers counter-clockwise.

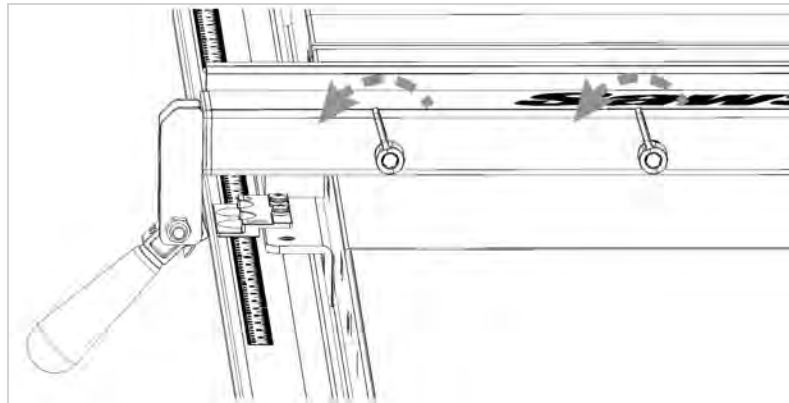

4. Pull the adjustable fence face rearward so that the front end is even with the first tooth of the blade (closest to the operator) as shown.

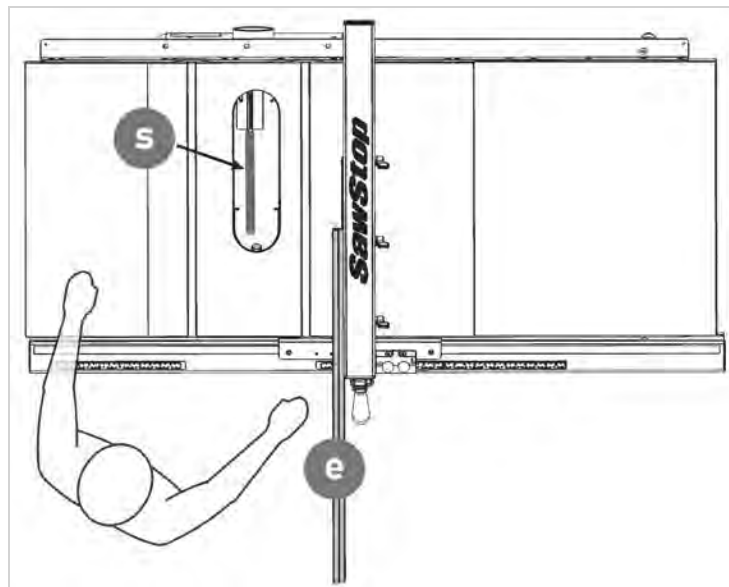

5. Lock the adjustable face in place by closing the lock levers you opened in step 3. Rotate the locking levers clockwise.

6. Place the workpiece (f) against the miter gauge body (g) and against the fence (e). Keep the workpiece clear of the blade.

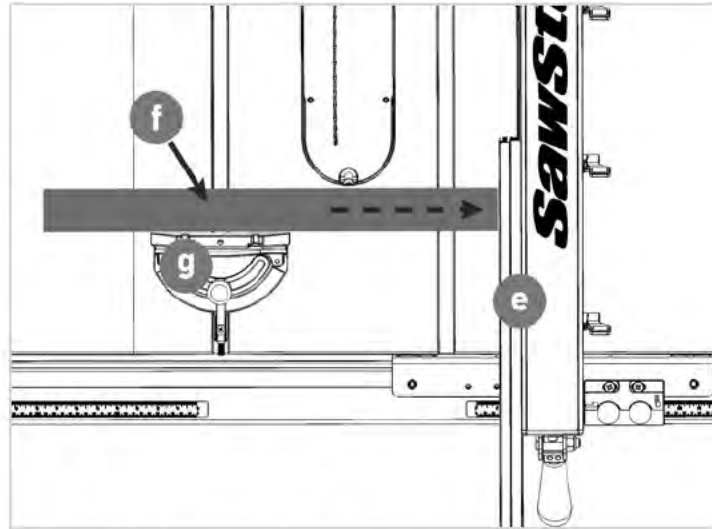

7. With the power switch on, pull the Start/Stop paddle to spin the blade.
8. While holding the workpiece firmly against the miter gauge body, move the miter gauge and workpiece across the saw table and through the blade.
9. After the cut is complete, note the off-cut piece sits safely in the gap between the blade and main fence body, thus preventing kickback.

USING THE LOW FENCE

When making narrow cuts, employing a low fence provides multiple advantages including improved visibility and providing better control over smaller, thinner workpieces. Perform the following steps to deploy the low fence.

1. Open the three locking levers (d) on the side of the main fence body to release the moveable fence face (e). Rotate the locking levers counter-clockwise.

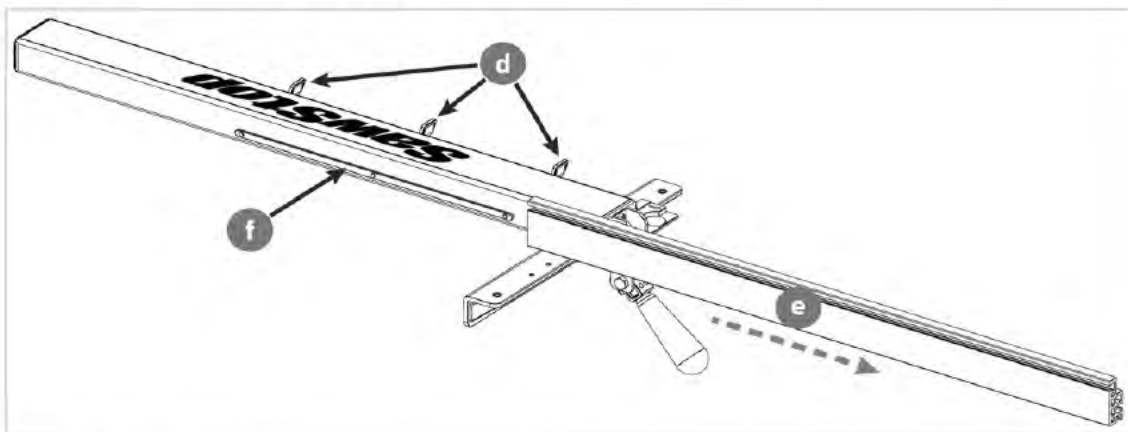

2. Slide the moveable fence face (e) rearward and completely separate it from the locking bar (f).

3. Rotate the moveable fence face (e) 90 degrees as shown and align the T track on the narrow edge of the extrusion with the locking bar (f) that is mounted to the main fence body. Slide the extrusion onto the locking bar.

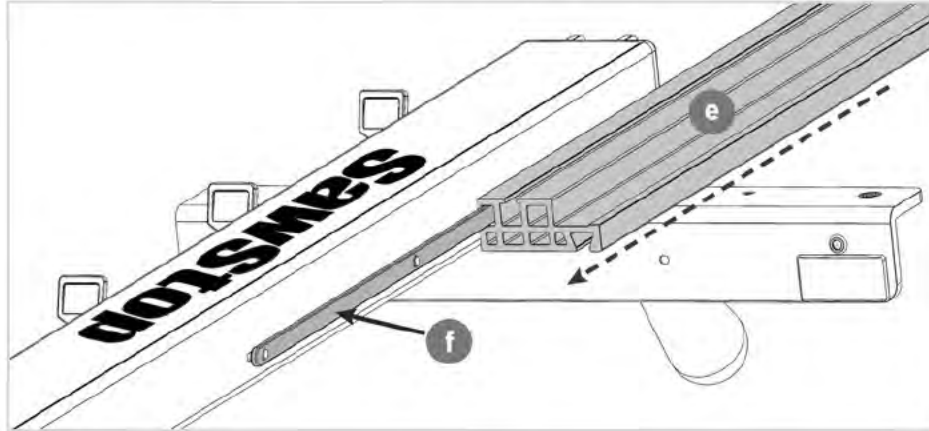

4. Lock the adjustable fence face in place by closing the locking levers you opened in step 1. (Rotate the locking levers clockwise.)

REVERSING THE FENCE



WARNING:

This saw is equipped with a left-tilting blade. Using the fence to the left of the blade increases the chance of contact with the fence and safety system activation. Take care to maintain adequate clearance between the top of the blade and fence.

The adjustable, aluminum face of the SawStop T-Glide Advance Fence must be installed so that it is facing the blade.

- a. When the fence is positioned to the right of the blade, the adjustable face must be installed on the left side of the main fence body.
- b. When the fence is positioned to the left of the blade, the adjustable face must be installed on the right side of the main fence body.

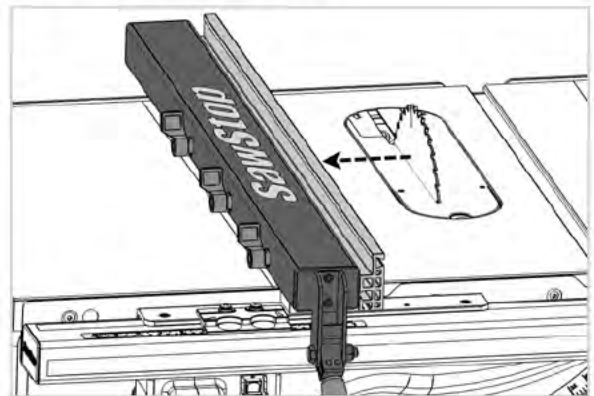
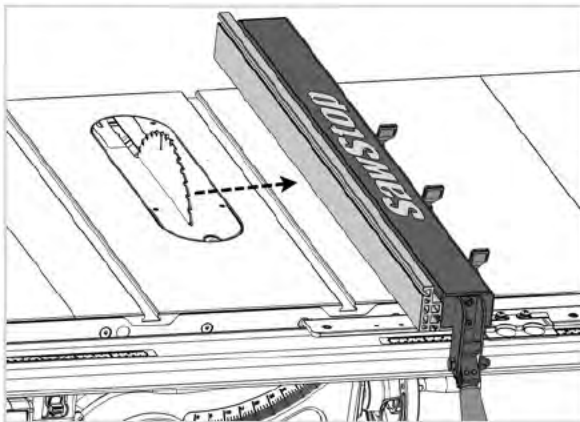

Follow the instructions below to reverse the fence configuration.

This example assumes that the adjustable fence face is currently installed on the left side of the main fence body (as shown above at left) and needs to be moved to the right side of the main fence body (as shown above at right). Should the reverse of this be the case, the same instructions for disassembly and re-assembly apply.

1. Open all three locking levers (d) by rotating them counter-clockwise and remove the adjustable aluminum face (e) from the main fence body.

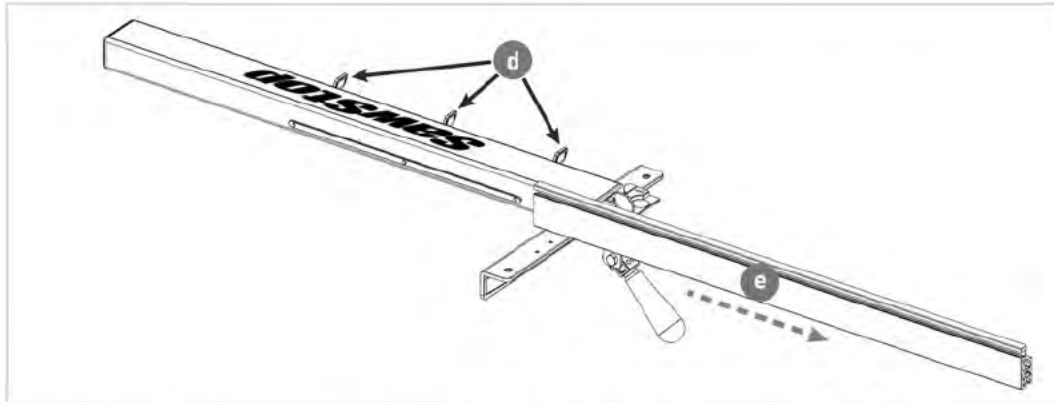

2. With the main fence body laying on it's side (locking levers facing up), depress the locking knob against the main fence body. Note the hex bolt head that is now exposed.

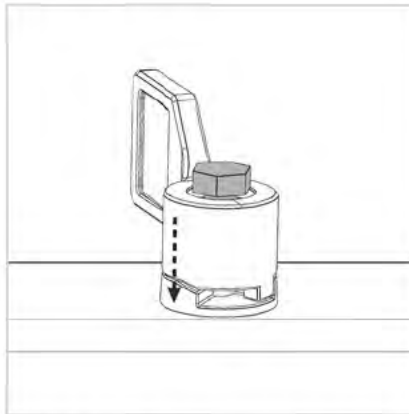

3. Rotate the bolt counter clockwise to remove it from the assembly. Set the bolt, locking knob, spring and base aside for later reassembly.



4. Repeat the previous step for the remaining two locking levers. Note that the locking bar located opposite the locking levers is now free.

5. Move the locking bar to the right side of the main fence body and align the holes in the locking bar with the holes in the main fence body.



6. Reassemble one of the locking levers with their respective bolt and spring. Insert this assembly into one of the holes in the left side of the fence and thread the bolt into the hole in the locking bar.

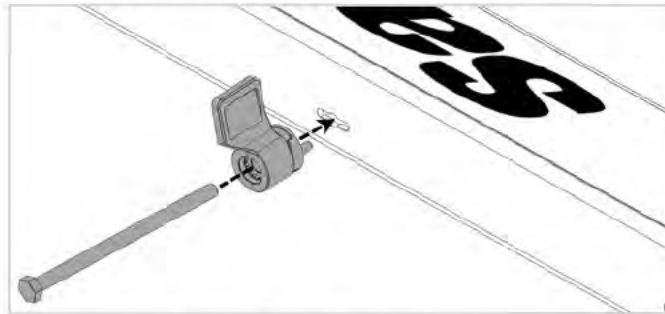

7. Repeat the previous step for the remaining locking knob assemblies.
8. Remove the screws and washers securing the indicator lens shown below and move the indicator lens to left side of the main fence tube. Secure it in place with the same screws and washers.

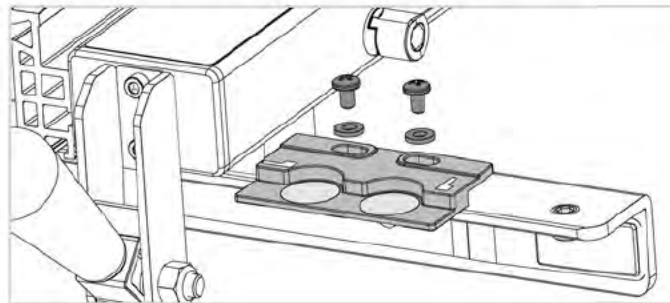

NOTE:

Before fully tightening the screws, perform the steps to zero the cursor line with the ruler. See the instructions on page 14.

NOTE:

The meaning of the high fence and low fence symbols above each indicator lens will be reversed when used in this configuration.

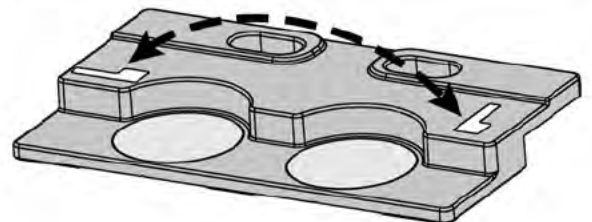

WORK HELPER FOR GROOVING

For an extra measure of safety and capability, consider making this horizontal fence to serve as a guard when performing non-through (grooving/dado) cuts. (Note that this is unnecessary if the SawStop Floating Dust Collection accessory for top side dust collection is installed.)

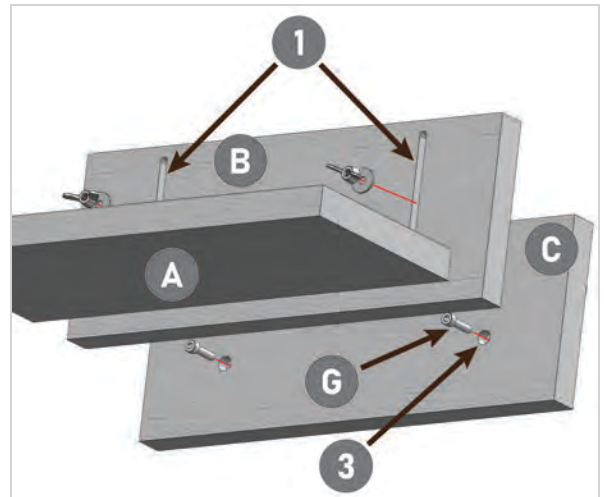
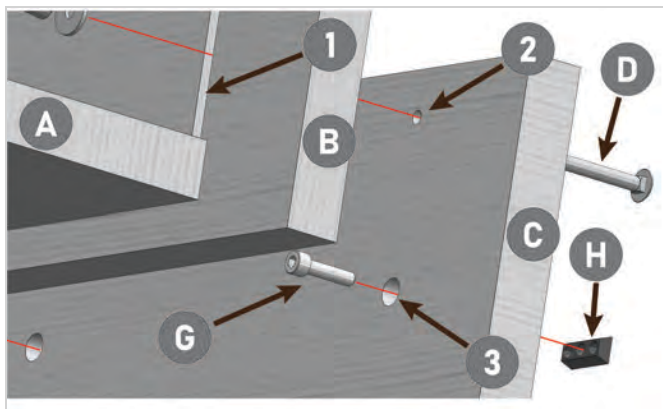
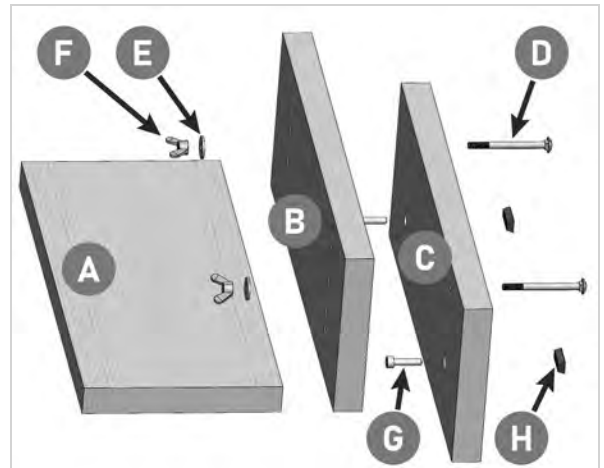
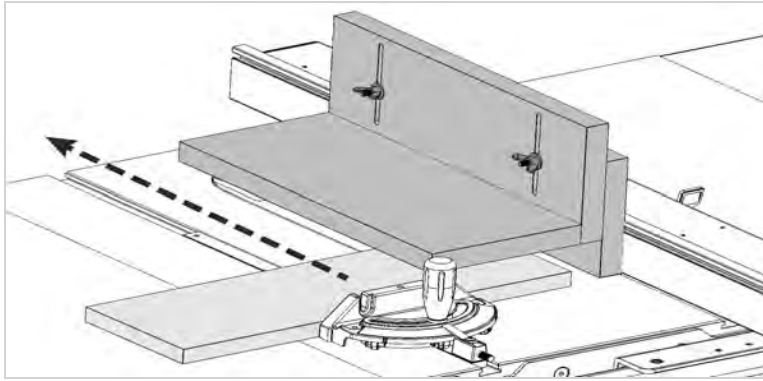

MATERIALS LIST AND CONSTRUCTION NOTES

PART	SPECIFICATIONS	NOTES
A. Board	400mm x 200mm x 19mm	Attach to Board B with glue.
B. Board	400mm x 152mm x 19mm	(1) Cut two elongated, vertical slots to fit the diameter of carriage bolts (D).
C. Board	400mm x 152mm x 19mm	(2) Drill the upper holes in Board C to fit diameter of carriage bolts (D) and that align with the vertical slots (1) in Board B. Chisel out back side of hole to create a square opening. This will receive the square portion of carriage bolts (D) so that the bolt does not rotate when the wing nuts (F) are tightened.. (3) Drill lower holes to fit diameter of M6 Socket head screws (G) and that align with dovetail-shaped track at the top of the adjustable extrusion of your T-Glide Advance fence. Counter sink these so that head of Socket head screws (E) are not proud of this board.
D. Carriage Bolts	M6 x 70mm	Quantity 2
E. Flat washer	M6 x 20mm OD	Quantity 2
F. Wing nut	M6	Quantity 2
G. Socket head screw	M6 x 25mm	Quantity 2 - Secures board C to the factory fence using the dovetail-shaped sliding wedges (H)
H. Dovetail-shaped sliding wedges	(Included)	Receives M6 cap screws (G) to secure board C to the factory fence. See page 1 for more information on sliding wedges.

Installing the Horizontal Fence

1. Install the T-Glide Advance Fence onto your table saw.
2. With the dovetail-shaped sliding wedges (H) installed onto Board C as shown and loosely threaded onto the M6 socket head screws (G), slide the wedges into the dovetail-shaped track located at the top of the adjustable face of your T-Glide Advance Fence.
3. Position Board C across from the blade then secure it to the fence extrusion by tightening the M6 socket head screws.

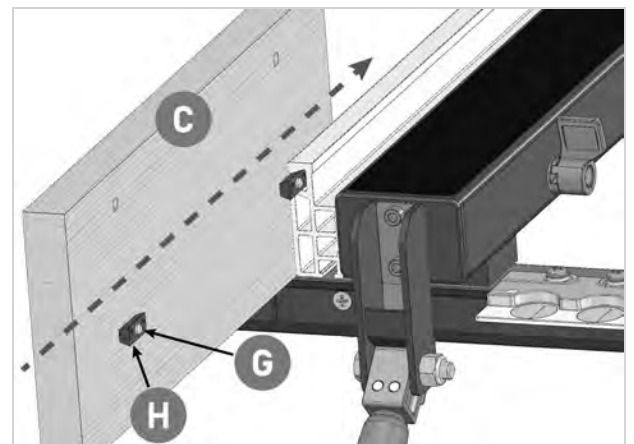

4. Attach the rest of the horizontal fence to Board C using the carriage bolts, washers and wing nuts as shown.

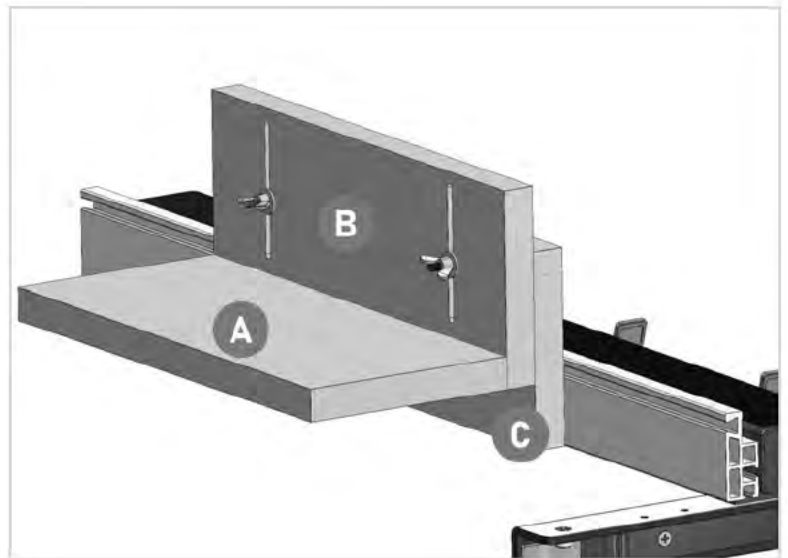

Using the Horizontal Fence

There are numerous uses for a horizontal fence including cutting tapers or duplicating the cuts on an existing workpiece. The example below describes employing it as a guard when grooving (dado or rabbet cutting).

1. Install your blade or dado stack and set the desired cutting height.
2. Adjust the height of the horizontal fence to be slightly higher than the thickness of the workpiece to be cut.
 - a. Loosen both wing nuts slightly
 - b. Slide the fence up or down as needed.
 - c. Re-tighten the wing nuts.
3. Position your factory fence for the desired width of cut, taking into account the thickness of Board C. The horizontal fence should cover the blade to provide the intended measure of safety.
4. Proceed with making the groove cut by guiding the workpiece against Board C (the portion of the jig that is attached to the factory fence).

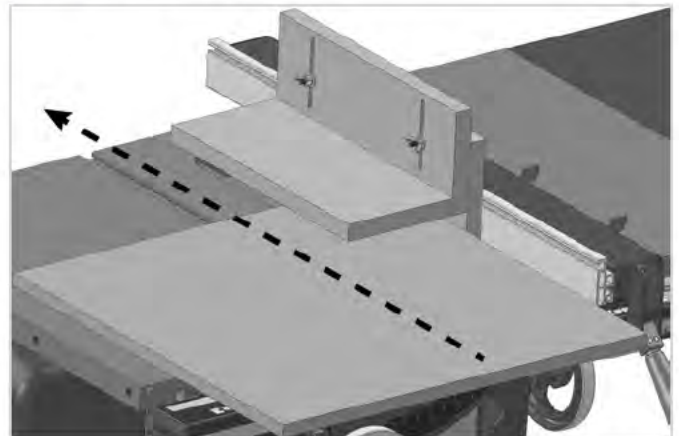

NOTES



NOTES



NOTES





USA/CANADA

SawStop, LLC

11555 SW Myslony St,
Tualatin, OR 97062 USA

SawStop.com/support

Service@SawStop.com
(503) 582-9934

Parts available for purchase at SawStop.com

EUROPE/UK

TTS Europe SE

Wertstrasse 20
73240 Wendlingen a.N., DE

UK Rep

Authorised Rep Compliance Ltd., ARC House,
Thurnham, Lancaster, LA2 0DT, UK.

SawStop.eu/support

SupportEurope@SawStop.com

AUSTRALIA

Carbatec.com.au/contact

customer@carbatec.com.au