

EN

DE

FR

ES

IT

NL

SV

FI

DA

NB

PT

CS

PL



Safety and General Use Instructions for Table Saws

Topics Include:

- General Power Tool Safety Warnings
- Safety Instructions for Table Saws
- The SawStop Safety System
- Work Helpers
- Cut Types

85-007612-00
Rev C - 07102025

GENERAL POWER TOOL SAFETY WARNINGS



WARNING:

Read all safety warnings, instructions, illustrations and specifications provided with this power tool. Failure to follow all instructions listed below may result in electric shock, fire and/or serious injury. Read and understand the maintenance and adjustment instructions in the included Owner's Manual to maximize the life and performance of your saw. Save all warnings and instructions for future reference.

The term "power tool" in the warnings refers to your mains-operated (corded) power tool or battery-operated (cordless) power tool.

1) WORK AREA SAFETY

- a. **Keep work area clean and well lit.** *Cluttered or dark areas invite accidents.*
- b. **Do not operate power tools in explosive atmospheres, such as in the presence of flammable liquids, gases or dust.** *Power tools create sparks which may ignite the dust or fumes.*
- c. **Keep children and bystanders away while operating a power tool.** *Distractions can cause you to lose control.*

2) ELECTRICAL SAFETY

- a. **Power tool plugs must match the outlet. Never modify the plug in any way. Do not use any adapter plugs with earthed (grounded) power tools.** *Unmodified plugs and matching outlets will reduce risk of electric shock.*
- b. **Avoid body contact with earthed or grounded surfaces, such as pipes, radiators, ranges and refrigerators.** *There is an increased risk of electric shock if your body is earthed or grounded.*
- c. **Do not expose power tools to rain or wet conditions.** *Water entering a power tool will increase the risk of electric shock.*
- d. **Do not abuse the cord. Never use the cord for carrying, pulling or unplugging the power tool. Keep cord away from heat, oil, sharp edges or moving parts.** *Damaged or entangled cords increase the risk of electric shock.*

- e. **When operating a power tool outdoors, use an extension cord suitable for outdoor use.** *Use of a cord suitable for outdoor use reduces the risk of electric shock.*
- f. **If operating a power tool in a damp location is unavoidable, use a Ground Fault Circuit Interrupter (GFCI) protected supply.** *Use of a GFCI reduces the risk of electric shock.*

3) PERSONAL SAFETY

- a. **Stay alert, watch what you are doing and use common sense when operating a power tool. Do not use a power tool while you are tired or under the influence of drugs, alcohol or medication.** *A moment of inattention while operating power tools may result in serious personal injury.*
- b. **Use personal protective equipment. Always wear eye protection.** *Protective equipment such as a dust mask, non-skid safety shoes, hard hat or hearing protection used for appropriate conditions will reduce personal injuries.*
- c. **Prevent unintentional starting. Ensure the switch is in the off-position before connecting to power source and/or battery pack, picking up or carrying the tool.** *Carrying power tools with your finger on the switch or energising power tools that have the switch on invites accidents.*
- d. **Remove any adjusting key or wrench before turning the power tool on.** *A wrench or a key left attached to a rotating part of the power tool may result in personal injury.*
- e. **Do not overreach. Keep proper footing and balance at all times.** *This enables better control of the power tool in unexpected situations.*
- f. **Dress properly. Do not wear loose clothing or jewellery. Keep your hair and clothing away from moving parts.** *Loose clothes, jewellery or long hair can be caught in moving parts.*
- g. **If devices are provided for the connection of dust extraction and collection facilities, ensure these are connected and properly used.** *Use of dust collection can reduce dust-related hazards.*
- h. **Do not let familiarity gained from frequent use of tools allow you to become complacent and ignore tool safety principles.** *A careless action can cause severe injury within a fraction of a second.*

4) POWER TOOL USE AND CARE

- a. **Do not force the power tool. Use the correct power tool for your application.** *The correct power tool will do the job better and safer at the rate for which it was designed.*
- b. **Do not use the power tool if the switch does not turn it on and off.** *Any power tool that cannot be controlled with the switch is dangerous and must be repaired.*
- c. **Disconnect the plug from the power source and/or remove the battery pack, if detachable, from the power tool before making any adjustments, changing accessories, or storing power tools.** *Such preventive safety measures reduce the risk of starting the power tool accidentally.*
- d. **Store idle power tools out of the reach of children and do not allow persons unfamiliar with the power tool or these instructions to operate the power tool.** *Power tools are dangerous in the hands of untrained users.*
- e. **Maintain power tools and accessories. Check for misalignment or binding of moving parts, breakage of parts and any other condition that may affect the power tool's operation. If damaged, have the power tool repaired before use.** *Many accidents are caused by poorly maintained power tools.*
- f. **Keep cutting tools sharp and clean.** *Properly maintained cutting tools with sharp cutting edges are less likely to bind and are easier to control.*
- g. **Use the power tool, accessories and tool bits etc. in accordance with these instructions, taking into account the working conditions and the work to be performed.** *Use of the power tool for operations different from those intended could result in a hazardous situation.*
- h. **Keep handles and grasping surfaces dry, clean and free from oil and grease.** *Slippery handles and grasping surfaces do not allow for safe handling and control of the tool in unexpected situations.*

5) SERVICE

- a. **Have your power tool serviced by a qualified repair person using only identical replacement parts.** *This will ensure that the safety of the power tool is maintained.*

SAFETY INSTRUCTIONS FOR TABLE SAWS

1) GUARDING RELATED WARNINGS

- a. **Keep guards in place. Guards must be in working order and be properly mounted.** *A guard that is loose, damaged, or is not functioning correctly must be repaired or replaced.*
- b. **Always use sawblade guard, riving knife* and anti-kickback pawls* for every through-cutting operation.** *For through-cutting operations where the saw blade cuts completely through the thickness of the workpiece, the guard and other safety devices help reduce the risk of injury.*
- c. **After completing a non-through cut such as rabbeting (rebating), resawing, or dadoing, restore the riving knife to the extended-up position. With the riving knife in the extended-up position, reattach the blade guard.** *The blade guard, riving knife*, and anti-kickback device* help to reduce the risk of injury.*
- d. **Make sure the saw blade is not contacting the guard, riving knife or the workpiece before the switch is turned on.** *Inadvertent contact of these items with the saw blade could cause a hazardous condition.*
- e. **Adjust the riving knife* as described in this instruction manual.** *Incorrect spacing, positioning and alignment can make the riving knife ineffective in reducing the likelihood of kickback.*
- f. **For the riving knife* and anti-kickback pawls* to work, they must be engaged in the workpiece.** *The riving knife* and anti-kickback device* are ineffective when cutting workpieces that are too short to be engaged with the riving knife and anti-kickback device. Under these conditions a kickback cannot be prevented by the riving knife and antikickback device.*
- g. **Use the appropriate saw blade for the riving knife.** *For the riving knife* to function properly, the saw blade diameter must match the appropriate riving knife* and the body of the saw blade must be thinner than the thickness of the riving knife and the cutting width of the saw blade must be wider than the thickness of the riving knife.*

* Applicable if present in your chosen configuration. This device is an optional accessory in some regions.

2) CUTTING PROCEDURE WARNINGS

- a. **DANGER!** Never place your fingers or hands in the vicinity or in line with the saw blade. A moment of inattention or a slip could direct your hand towards the saw blade and result in serious personal injury.
- b. Feed the workpiece into the saw blade only against the direction of rotation. Feeding the workpiece in the same direction that the saw blade is rotating above the table may result in the workpiece, and your hand, being pulled into the saw blade.
- c. Never use the miter gauge to feed the workpiece when ripping and do not use the rip fence as a length stop when cross cutting with the miter gauge. Guiding the workpiece with the rip fence and the miter gauge at the same time increases the likelihood of saw blade binding and kickback.
- d. When ripping, always apply the workpiece feeding force between the fence and the saw blade. Use a push stick when the distance between the fence and the saw blade is less than 150 mm, and use a push block when this distance is more than 150 mm. "Work helping" devices will keep your hand at a safe distance from the saw blade.
- e. Use only the push stick provided by the manufacturer or constructed in accordance with the instructions. This push stick provides sufficient distance of the hand from the saw blade.
- f. Never use a damaged or cut push stick. A damaged push stick may break causing your hand to slip into the saw blade.
- g. Do not perform any operation "freehand." Always use either the rip fence or the miter gauge to position and guide the workpiece. "Freehand" means using your hands to support or guide the workpiece, in lieu of a rip fence or miter gauge. Freehand sawing leads to misalignment, binding and kickback.
- h. Never reach around or over a rotating saw blade. Reaching for a workpiece may lead to accidental contact with the moving saw blade.
- i. Provide auxiliary workpiece support to the rear and/or sides of the saw table for long and/or wide workpieces to keep them level. A long and/or wide workpiece has a tendency to pivot on the table's edge, causing loss of control, saw blade binding

and kickback.

- j. Feed the workpiece at an even pace. Do not bend, twist or shift the workpiece from side to side. If jamming occurs, turn the tool off immediately, unplug the tool, then clear the jam. Jamming the saw blade by the workpiece can cause kickback or stall the motor.
- k. Do not remove pieces of cut-off material while the saw is running. The material may become trapped between the fence or inside the saw blade guard and the saw blade pulling your fingers into the saw blade. Turn the saw off and wait until the saw blade stops before removing material.
- l. Use an auxiliary fence in contact with the table top when ripping workpieces less than 2 mm thick. A thin workpiece may wedge under the rip fence and result in kickback.

3) KICKBACK CAUSES AND WARNINGS

Kickback is a sudden reaction of the workpiece due to a pinched, jammed saw blade or misaligned line of cut in the workpiece with respect to the saw blade or when a part of the workpiece binds between the saw blade and the rip fence or other fixed object.

Most frequently during kickback, the workpiece is lifted from the table by the rear portion of the saw blade and is propelled towards the operator.

Kickback is the result of saw misuse and/or incorrect operating procedures or conditions and can be avoided by taking proper precautions as given below.

- a. Never stand directly in line with the saw blade. Always position your body on the same side of the saw blade as the fence. Kickback may propel the workpiece at high velocity towards anyone standing in front and in line with the saw blade.
- b. Never reach over or in back of the saw blade to pull or to support the workpiece. Accidental contact with the saw blade may occur or kickback may drag your fingers into the saw blade.
- c. Never hold and press the workpiece that is being cut off against the rotating saw blade. Pressing the workpiece being cut off against the saw blade will create a binding condition and kickback.
- d. Align the fence to be parallel with the saw blade. A misaligned rip fence will pinch the workpiece

against the saw blade and create kickback.

- e. **Use a featherboard to guide the workpiece against the table and fence when making non-through cuts such as rabbeting (rebating), dadoing or resawing cuts.** *A featherboard helps to control the workpiece in the event of a kickback.*
- f. **Use extra caution when making a cut into blind areas of assembled workpieces.** *The protruding saw blade may cut objects that can cause kickback.*
- g. **Support large panels to minimize the risk of saw blade pinching and kickback.** *Large panels tend to sag under their own weight. Support(s) must be placed under all portions of the panel overhanging the table top.*
- h. **Use extra caution when cutting a workpiece that is twisted, knotted, warped or does not have a straight edge to guide it with a miter gauge or along the fence.** *A warped, knotted, or twisted workpiece is unstable and causes misalignment of the kerf with the saw blade, binding and kickback.*
- i. **Never cut more than one workpiece, stacked vertically or horizontally.** *The saw blade could pick up one or more pieces and cause kickback.*
- j. **When restarting the saw with the saw blade in the workpiece, center the saw blade in the kerf so that the saw teeth are not engaged in the material.** *If the saw blade binds, it may lift up the workpiece and cause kickback when the saw is restarted.*
- k. **Keep saw blades clean, sharp, and with sufficient set. Never use warped saw blades or saw blades with cracked or broken teeth.** *Sharp and properly set saw blades minimize binding, stalling and kickback.*
- c. **Locate the table saw in a well-lit and level area where you can maintain good footing and balance.** *It should be installed in an area that provides enough room to easily handle the size of your workpiece. Cramped, dark areas, and uneven slippery floors invite accidents.*
- d. **Frequently clean and remove sawdust from under the saw table and/or the dust collection device.** *Accumulated sawdust is combustible and may self-ignite.*
- e. **The table saw must be secured.** *A table saw that is not properly secured may move or tip over.*
- f. **Remove tools, wood scraps, etc. from the table before the table saw is turned on.** *Distraction or a potential jam can be dangerous.*
- g. **Always use saw blades with correct size and shape (diamond versus round) of arbour holes.** *Saw blades that do not match the mounting hardware of the saw will run off-centre, causing loss of control.*
- h. **Never use damaged or incorrect saw blade mounting means such as flanges, saw blade washers, bolts or nuts.** *These mounting means were specially designed for your saw, for safe operation and optimum performance.*
- i. **Never stand on the table saw, do not use it as a stepping stool.** *Serious injury could occur if the tool is tipped or if the cutting tool is accidentally contacted.*
- j. **Make sure that the saw blade is installed to rotate in the proper direction. Do not use grinding wheels, wire brushes, or abrasive wheels on a table saw.** *Improper saw blade installation or use of accessories not recommended may cause serious injury.*

4) TABLE SAW OPERATING PROCEDURE WARNINGS

- a. **Turn off the table saw and disconnect the power cord when removing the table insert, changing the saw blade or making adjustments to the riving knife*, antikickback device* or saw blade guard, and when the machine is left unattended.** *Precautionary measures will avoid accidents.*
- b. **Never leave the table saw running unattended. Turn it off and don't leave the tool until it comes to a complete stop.** *An unattended running saw is an uncontrolled hazard.*

* Applicable if present in your chosen configuration. This device is an optional accessory in some regions.

MORE ABOUT ELECTRICAL SAFETY

- a. **Ensure the machine is isolated from all power sources. Always turn off the main power switch and unplug the power cord before working on or maintaining your saw.**

- b. Never operate the tool with the access doors open. Do not attempt to bypass or defeat the access door interlock switches. Should the door interlock switches require adjusting or re-aligning, turn off and disconnect main power from the tool first.
- c. In case of power supply failure, the blade will take longer to stop (approximately 10 seconds). Wait for the blade to completely stop before opening doors or placing hands near blade.
- d. To restart the saw after unexpected loss of power, push the start/stop paddle in and turn the main power switch to the off position. When power is restored, turn on the saw according to the instructions provided in the owner's manual included with your saw.
- e. If working in a damp environment or cutting metal, it is important to plug the saw into a Residual Current Device (RCD), also known as a Ground Fault Circuit Interrupter (GFCI).
- f. For stationary cabinet saws (Professional Cabinet Saw and Industrial Cabinet Saw models), the machine must be connected to a circuit protected with a 16A circuit breaker with tripping characteristic C and overvoltage protection. If connected to a circuit protected by fuses, use time delay fuse marked D.
- g. All SawStop table saws must be connected to a grounded wiring system or to a system having an equipment grounding conductor. Failure to connect the saw to an adequate electrical ground may prevent the safety system from detecting human contact and could result in a serious injury. Do not power this saw by a generator or battery inverter unless the generator or battery inverter is connected to a dedicated ground connection. Do not use a generator or battery inverter that is not itself grounded. Have a qualified electrician or service personnel check grounding before using a generator or battery inverter. Note that when using anything other than a public power source, performance of the saw cannot be guaranteed due to the variable nature of the quality and consistency of electrical power from alternative power sources. Improper connection of the equipment-grounding conductor can result in a risk of electric shock and/or malfunction. Plug type varies by model and power requirements. In the event of a malfunction or breakdown,

grounding provides a path of least resistance for electric current to reduce the risk of electric shock. The plug must be plugged into a matching outlet that is properly installed and grounded in accordance with all local codes and ordinances. This saw is equipped with an electric cord having an equipment grounding conductor (B) and a grounding plug (A). The 120V variant is illustrated below; the cord on your saw and plug type for your country/region may differ.

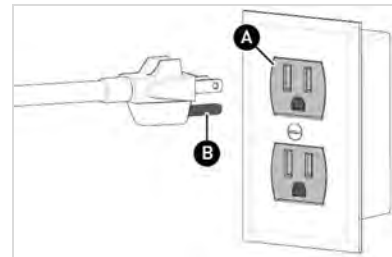

The conductor with insulation having an outer surface that is green with or without yellow stripes is the equipment-grounding conductor. If repair or replacement of the electric cord or plug is necessary, do not connect the equipment-grounding conductor to a live terminal.

1. Check with a qualified electrician or service personnel if the grounding instructions are not completely understood or if in doubt as to whether the saw is properly grounded. Use only 3-wire extension cords that have 3-prong grounding plugs and 3-pole receptacles that accept the saw's plug. Repair or replace a damaged or worn cord immediately.
- h. Plug must match outlet that is properly installed and grounded in accordance with all local codes and ordinances.
 - i. Do not modify plug – if it will not fit the outlet, have proper outlet installed by qualified electrician.
 - j. Use a proper extension cord. Make sure your extension cord is in good condition. When using an extension cord, be sure to use one heavy enough to carry the current your saw will draw. An undersized cord will cause a drop in line voltage resulting in loss of power and overheating. When adding an extension cord to your saw, refer to the guidelines in the table below that is applicable to your saw model's power requirements. If in doubt, use the next heavier gauge. The smaller the gauge

number, the heavier the cord.

Minimum Extension Cord Gauge for 110-120V	
Length	Gauge
0-25 Feet	12 AWG
25-50 Feet	10 AWG
Over 50 Feet	Not Recommended

Minimum Extension Cord Gauge for 208-240V Wiring	
Length	Gauge
0-50 Feet	14 AWG
50-100 Feet	12 AWG
Over 100 Feet	Not Recommended

Minimum Extension Cord Gauge for 230V (EU/UK)	
Length	Gauge
~15m	1.5mm ²
Over 15m	Not Recommended

THE SAW STOP SAFETY SYSTEM

Essential information about the SAWSTOP SAFETY SYSTEM

This product is equipped with **SawStop's active injury mitigation (AIM) technology**. This revolutionary technology was developed to reduce the potential for a serious injury in the event of accidental contact with the saw blade.

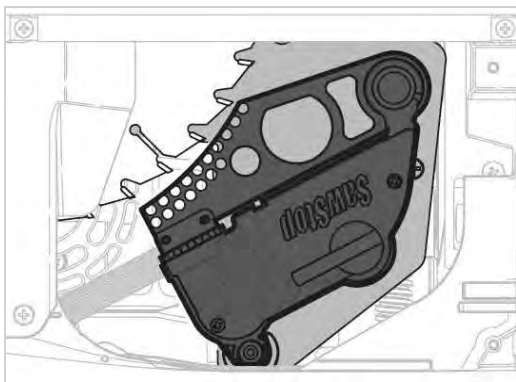

The brake cartridge in your saw may look slightly different.

Because of the AIM technology, your SawStop saw operates differently than ordinary table saws, and there are a few important points to keep in mind as you use the saw.

1. Do not rely on the safety system to protect against unsafe operation.

Although the system is designed to react and stop the blade very quickly in the event of accidental contact, it cannot react until contact is detected. This means that you may receive at least a minor injury. Therefore, always use safe operating practices, and use the blade guard, push stick and other safety devices whenever possible. The safety system, like the airbag in a car, should be considered as a last measure to minimize injury when all other safety practices and devices have failed to prevent an accident. Never try to intentionally trigger the safety system.

2. In the event of contact, the blade will be stopped in about 3-5 milliseconds (coarse-toothed blades stop more quickly than fine-toothed blades such as plywood blades). Therefore, the seriousness of the injury incurred will depend on the speed at which a person's hand or other body part is moving toward the blade. At faster speeds, it is possible to be seriously injured even with a SawStop saw.

3. Your SawStop saw includes a Bypass Mode that allows you to cut electrically conductive materials. Do not operate the saw in Bypass Mode unless you are cutting electrically conductive material. When Bypass Mode is engaged, the safety system will not activate if contact is detected and a serious injury could result if you contact the blade. Detailed instructions regarding Bypass Mode can be found in the owner's manual for your saw.

4. The motor cannot be started without a blade installed.

Since the safety system disables the motor if the blade is spaced too far from the brake, a missing blade will be detected as a blade-to-brake spacing error and the motor will be disabled.

5. Blades: You can use any standard 10-inch (254mm) and 250mm saw blades.

The following precautions should be observed:

- Do not use molding heads. The use of molding heads could result in a serious injury because the brake cartridge is not designed to stop a molding head.
- Never use a blade with damaged or missing teeth as this can result in a more serious

injury or an activation of the brake. Blades with variable spacing between teeth are compatible with your SawStop saw, however you must ensure the brake is positioned correctly by rotating the blade at least one full revolution to be certain that none of the teeth touch the brake.

- c. Never install the blade backwards. The brake might not stop a blade that is installed backwards.
- d. Do not use saw blades that have a lacquer or other coating on the teeth. These coatings are non-conductive and therefore can reduce the speed at which the system detects contact. Used blades that originally had a coating are OK to use since the coating is worn away within a few uses. However, SawStop recommends that you examine each tooth on such blades to confirm that no coating remains.
- e. Blades with depth-limiting shoulders may take longer to stop in the event of an accident than standard blades, and you could receive a more serious injury. Therefore, SawStop recommends using blades without depth-limiting shoulders.
- f. The SawStop safety system is designed for use with standard 10-inch (254mm) and 250mm blades with kerfs from 3/32 inch to 3/16 inch. Blades with kerfs thinner than 3/32 inch should not be used because those blades might not be strong enough to withstand the force applied by the brake when it activates. As a result, those blades might deform and stop more slowly in the event of an accident, resulting in a more serious injury. Blades with kerfs thicker than 3/16 inch are heavier than standard 1/8-inch kerf blades, and should not be used because they may stop more slowly than standard blades in the event of an accident, resulting in a more serious injury. Similarly, stacks of two or more blades should never be used on your SawStop saw as the combined weight of the blades may be too heavy to stop quickly.
- g. Never stack Dado blades thicker than 29/32". The 8 inch Dado brake cartridge is not designed to stop Dado stacks thicker

than 29/32".

- h. Do not use non-conductive blades, including abrasive blades, blades with plastic hubs, or blades that have non-conductive teeth. Only standard steel blades with either steel or carbide teeth should be used.
6. Do not use table inserts, guards, fences or other devices which have metal parts that may get into contact with the blade. **Any metal part that contacts the blade may cause the brake to activate.** All SawStop accessories are specifically designed to prevent metal contact with the blade.
- a. SawStop recommends maintaining a gap of at least 1/8" (3mm) between the blade and any conductive surfaces to avoid any chance of activation. One example is while using a metal miter fence. Applications that require the miter fence to be closer to the blade should be completed with a non-conductive miter fence attachment.
7. **Wet, pressure-treated wood may cause the brake to activate.**

The chemicals used to pressure-treat wood often contain large amounts of copper, which is conductive. When pressure-treated wood is wet, the combination of copper and water substantially increases the conductivity of the wood. Therefore, allow wet pressure-treated wood to fully dry before cutting. Typically, the wood will be sufficiently dry if left unstacked in a dry location for 24 hours. If you must cut wet pressure-treated wood, you can make several cuts in the wettest piece(s) using the Bypass Mode to test whether the wood is too wet. See the instructions on starting the saw in Bypass Mode (described in the owner's manual for your saw) and how to test the conductivity of a material. If the test indicates the wood is too wet to cut with the safety system active, you must either allow the wood to dry or make the remaining cuts in Bypass Mode.

8. **Never touch the arbor, arbor nut or arbor washer when the blade is spinning** because you may receive a serious injury. These parts are all electrically coupled to the blade and the brake will activate if contact with these parts is detected.
9. **Do not replace the arbor belt with a non-SawStop belt.** The SawStop arbor belt is custom designed to dissipate static electricity that may build up on the



spinning blade which could cause an unintended activation of SawStop safety system.

10. **Never reach under the blade while it is spinning.** In the event the brake is activated, the retraction of the blade may cause a serious injury if you contact the bottom of the blade.
11. Refrain from removing dust, chips, splinters or any other part of the workpiece from the cutting area while the machine is running.
12. Do not remove any guard or dust shroud because a large portion of the blade will be exposed. If you contact the blade under the table, the blade may retract toward you and cause a severe injury.
13. **Do not unplug or disconnect the saw from electrical power before the blade has stopped spinning.**

If the power is interrupted while the blade is moving, the safety system will not be active and therefore the brake will not activate in the event of accidental contact. You may receive a serious injury if you contact the spinning blade while the electrical power has been interrupted.
14. **Never attempt to disable the SawStop safety system or modify the electrical wiring of the saw** in any way. Any change or modification or disabling of the safety system or other wiring could result in a serious injury and will void all warranties.
15. **Never attempt to repair, adjust, modify or otherwise service a brake cartridge.** There are no user serviceable parts inside the brake cartridge. The brake cartridge is permanently sealed against dust and other contaminants. Destruction, removal, or alteration of this seal voids all warranties.



IMPORTANT:

Some SawStop models have additional blade type compatibility limitations not described in this chapter. See the **SPECIFICATIONS AND REQUIREMENTS** chapter of the owner's manual for your saw for additional, model-specific information.



NOTE:

See the owner's manual included with your saw for detailed instructions on how to replace the brake cartridge after an activation of the safety system.

POWER CONTROLS

The power controls on your SawStop saw are distinctive from other saws available in the marketplace. Understand that your machine is equipped with both a Main Power Switch* and a Start/Stop paddle. The Main Power Switch Activates power for the saw but does not spin the blade.

To start your saw...

1. Make sure the Start/Stop Paddle is in the off (pushed in) position, then turn the Main Power Switch* to the on (upward) position. This will turn on power to the SawStop safety system. A brief initialization routine will be performed to test whether the system is operating properly. During this initialization period (approximately 5–10 seconds), the two LEDs on the switch box may blink in different patterns as the safety system runs through various self-check steps.
2. Once the safety system completes the initialization routine, the LEDs will display the “READY” status display. The green LED is on solid and the red LED** is off.
3. The saw is now ready for use.
4. To start the motor, pull the Start/Stop Paddle out.

*The Main Power Switch is red and yellow in color in some regions and on some models, and gray in other regions and models.

** Note that some regional models employ a white LED instead of red.

To stop your saw...

Push the Start/Stop Paddle in.

It is not necessary to turn off the Main Power Switch after pushing in the Start/Stop Paddle to turn off the motor.

WARNING:

Do not use the Main Power Switch to stop the motor: The Main Power Switch does not completely cut power to the saw until the blade stops. This allows the SawStop safety system to stay active until the blade has stopped spinning. Thus, flipping the Main Power Switch to off and then back into the on position before the blade stops will cause the motor and blade to return to full speed. To ensure stoppage, the Start/Stop paddle should be always be pressed in first. This will keep the saw from restarting no matter the status of the Main Power Switch.

This saw includes safety functions certified per ISO 13849-1 including Prevention of Unexpected Start (as defined by ISO 19085-1:2021) and Normal Stop (as defined by ISO 19085-1:2021). These safety functions meet Category 2, PL=C with a response time ≤ 500 ms and MTTFD of 97 years (high). The safety functions are always present and do not require any user interaction to implement. Please see the Troubleshooting Section of the Owner's Manual included with your saw to learn how to reset your saw if either of these safety functions are activated.

ENVIRONMENT

For information about how to properly recycle this product, and to learn about SawStop's commitment to the environment, visit SawStop.eu/environment.

PROPOSITION 65 WARNING

WARNING:

Drilling, sawing, sanding or machining wood products can expose you to wood dust, a substance known to the State of California to cause cancer. Avoid inhaling wood dust or use a dust mask or other safeguards for personal protection. For more information go to www.P65Warnings.ca.gov/wood.

WORK HELPERS

NOTE:

Illustrations in this chapter may depict a model or configuration of table saw different than yours. The instructions provided however are universal and apply to all table saw models.

This section shows you how to make several accessories that help ensure effective and safe cutting. Each tool is constructed from wood. Grid squares in each of the following illustrations are 1" (25.4 mm).

HOW TO MAKE A PUSH STICK



Your saw comes with a push stick but you can also construct a replacement. The stock push stick is available for purchase from SawStop as well.

- Use a non-conductive material, for example, scrap wood
- 1/2" - 3/4" (12.7 mm - 19 mm) thick
- Use a push stick when ripping pieces narrower than 6" (152 mm)

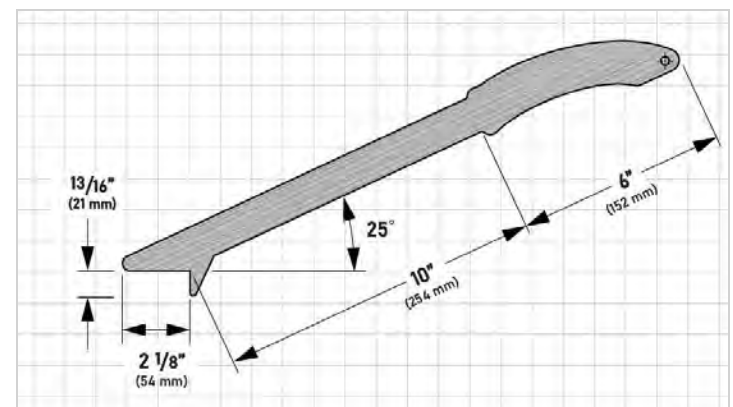

HOW TO MAKE A FEATHERBOARD

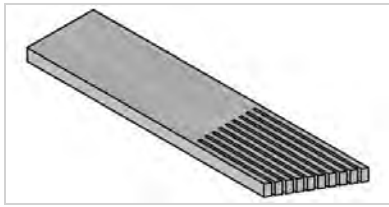

When using a push stick to feed the workpiece, you can use featherboards to maintain the position of the workpiece relative to the fence and table (see page 18).



Clamp a featherboard to the top of the table, against the side of the workpiece opposite the fence, to hold the workpiece flush against the fence.

You can also clamp a featherboard to the fence to hold the workpiece down against table surface.



WARNING:

To avoid risk of kickback, make sure the horizontal featherboard is mounted in front of the leading edge of the blade.

Grid squares in the following illustration are 1" (25.4 mm).

- 3/4" (19 mm) thick
- Use a quality wood without knots
- Do not use when cutting with the miter gauge

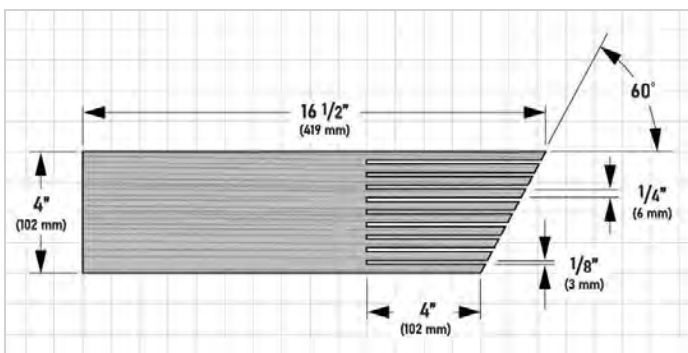

HOW TO MAKE AN AUXILIARY FENCE

Use an auxiliary fence and push block (plans described in this section) when a rip cut is too narrow (less than two inches) for a push stick. The auxiliary fence is attached to the stock fence using clamps.

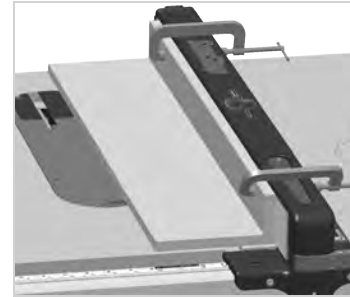

Slide workpiece along auxiliary fence. When your hand comes within 6" (150 mm) of blade, use a push block to finish cut.

Measure the height and length of your saw's existing fence. This will guide you in creating an auxiliary fence of the proper length. Note that the design example below is sized for a smaller, portable table saw and proper plan dimensions for your fence may vary. Pieces A and B shown are 1/2" (12.7 mm) thick. Grid squares in the following illustration are 1" (25.4 mm).

Attach part A to part B using wood screws and wood glue.

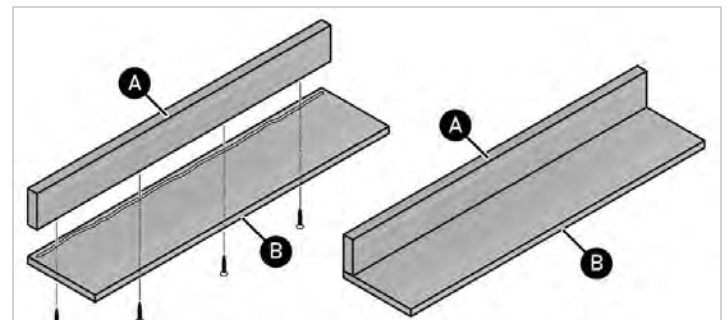
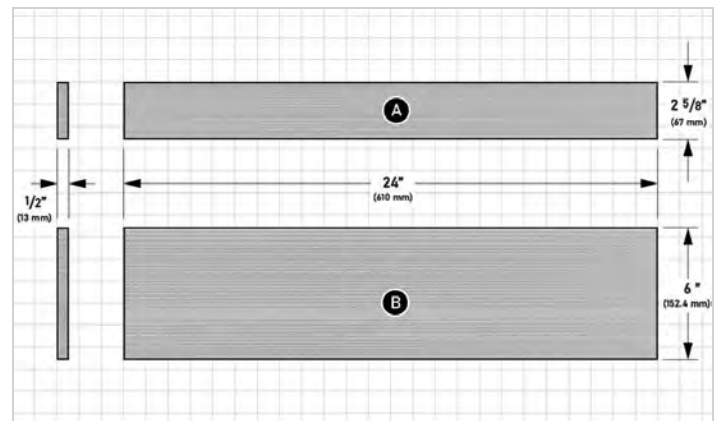

HOW TO MAKE A PUSH BLOCK

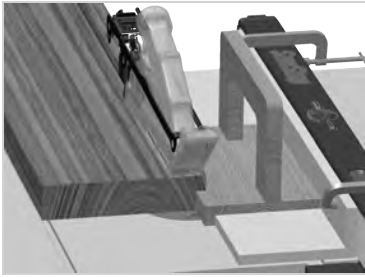

Use the push block with the auxiliary fence (plans described in this section) to facilitate narrow rip cuts (less than 2" [51 mm] wide) and to cut workpieces that are thinner than 2 mm.

Pieces B and C are 1/2" (12.7 mm) thick. Grid squares in the following illustration are 1" (25.4 mm).

- Attach part A to part B using wood screws and wood glue.
- Attach part C to part B using wood glue only (do not use metal fasteners).

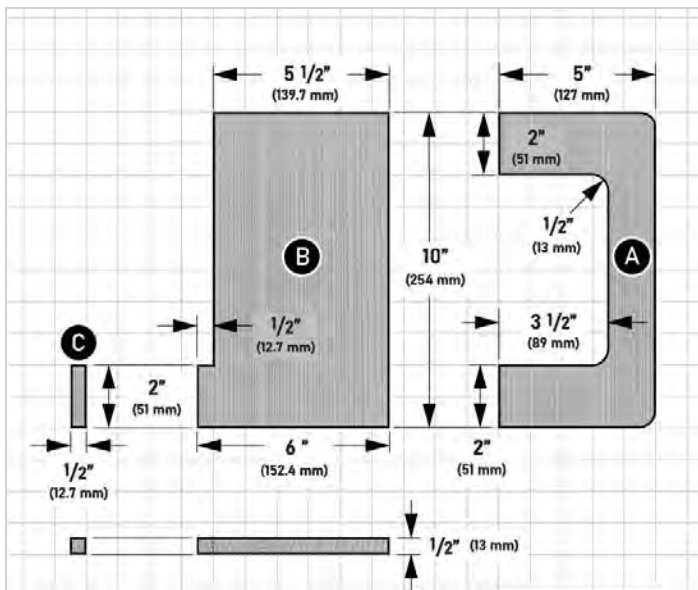
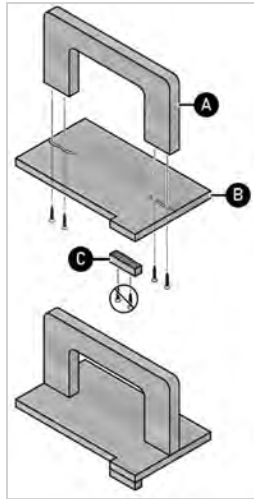

CUT TYPES

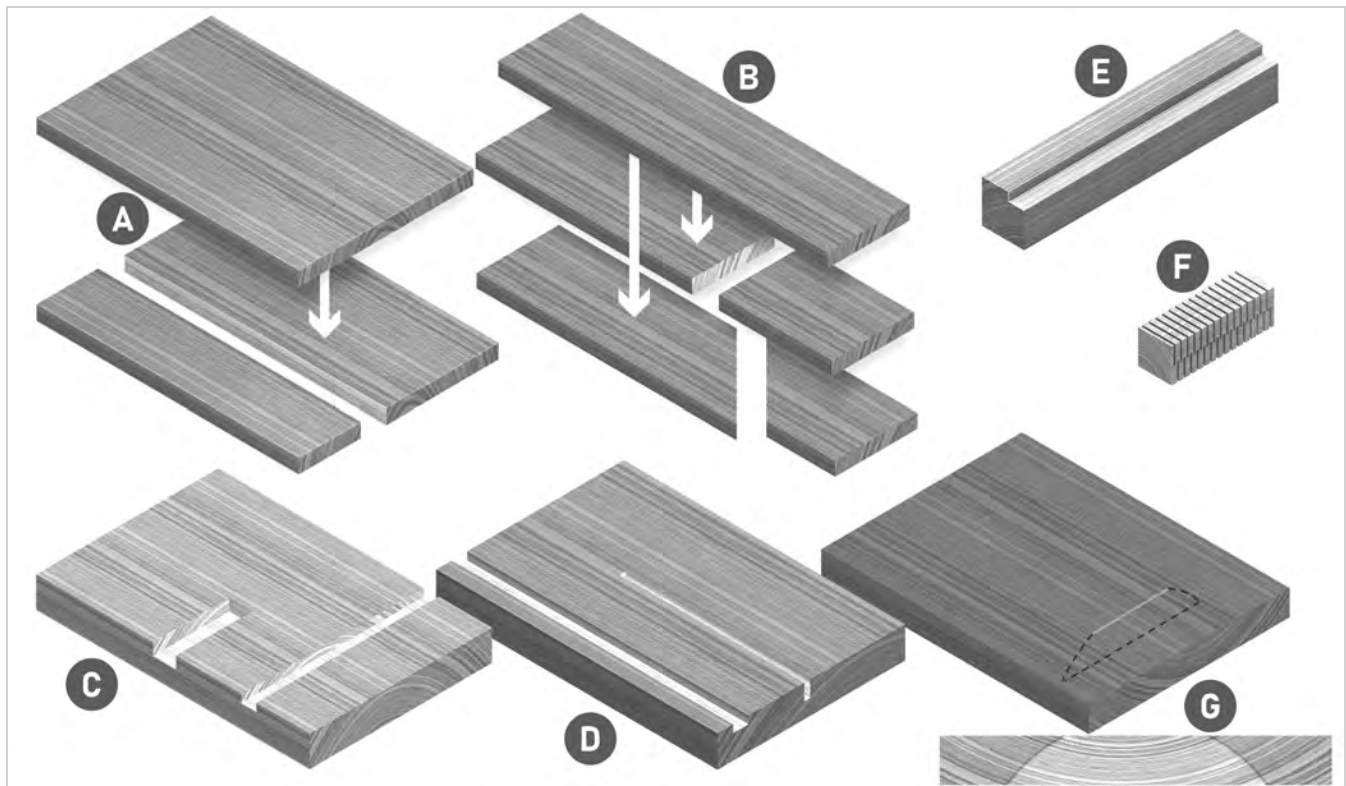

CUT TYPE	DEFINITION	PAGE
Through (A)	A cut through the entire thickness of the workpiece.	14
Rip (A)	A cut made with (parallel to) the grain of the workpiece.	14
Non-through	The blade does not cut through top of wood.	17
Cross (B)	A cut that runs perpendicular to the grain of workpiece.	15
Dado (C)	A non-through cut, made with special, stacked blades, and produces a rectangular-sided slot in workpiece. Can be a through-Dado or stopped Dado.	--
Groove (D)	Like a Dado cut but cut parallel to the grain.	--
Rabbet [Rebate] (E)	A non-through cut, where a rectangular notch along the length of workpiece is made.	19
Grooving (F)	Spaced or repeated cuts, on one or both sides of workpiece, to remove material so the workpiece can flex.	19
Plunge (G)	A cut that begins somewhere other than edge of workpiece.	18

NOTE:

Illustrations in this chapter may depict a model or configuration of table saw different than yours. The instructions provided however are universal and apply to all table saw models.

IMPORTANT:

Whenever possible, refrain from working without a blade guard when sawing and refrain from working with a safety appliance for grooving in the non-protective position when grooving.

RIP CUTS AND CROSS CUTS

The two primary categories of common cuts are:

- With the grain (rip cut)
- Across the grain (cross cut)

It's critical that you use the rip fence when making rip cuts and the miter gauge when making cross cuts. **Never cut any workpiece freehand.** Doing so can cause the workpiece to bind which can result in kickback (4). See the following pages to learn about cut types.

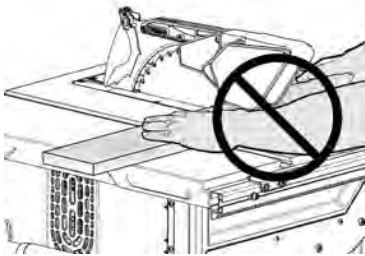

WARNING:

Always use either the rip fence or the miter gauge. Never attempt to cut freehand.

Rip Cut

A rip cut is created by cutting with the grain of the workpiece.

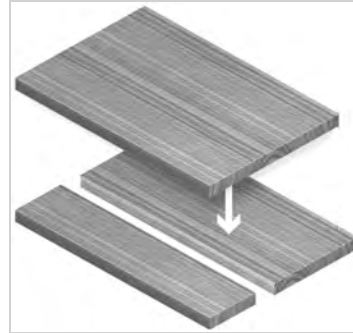

Always use the rip fence (A) when cutting with the grain.

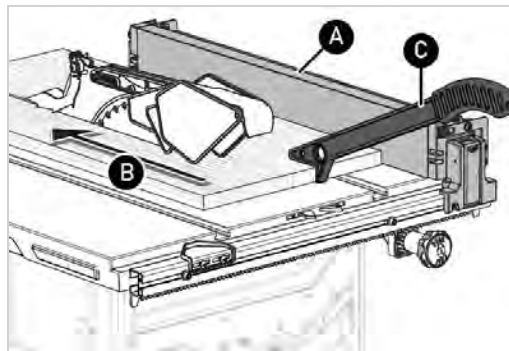

Use a push stick (C) when the distance between the rip fence and the saw blade is less than 150 mm (about 6"), and use a push block (see page 12) when this distance is more than 150 mm.

1. Tilt the blade to desired bevel angle as needed, and then adjust the blade elevation to about 1/8" to 1/4" (3 to 6 mm) higher than the workpiece.
2. Position the rip fence or low fence at the desired rip width and lock in place. Position the workpiece flat on the table and flush against the rip fence.
3. With the power switch on, pull the Start/Stop paddle to spin the blade.

WARNING:

Make sure the workpiece is not touching blade when starting motor.

4. Hold the workpiece squarely and firmly against the rip fence face and table. Push the workpiece slowly and smoothly toward and past the blade.

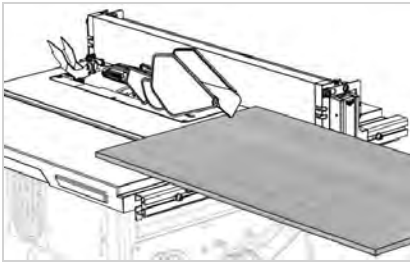

! WARNING:

Do not contact the rip fence with the spinning blade as it contains conductive materials. Contact will activate the brake system. When making narrow cuts and cutting workpieces that are thinner than 2 mm or cutting with a tilted blade, employing a low fence can help. Not all SawStop models are equipped with a low fence feature. See your saw owner's manual or fence system manual for more information.

5. When cutting long material, ensure adequate support so the workpiece does not move or shift as it moves past the edge of the table.

Use a push stick if your hand comes within 6" (150 mm) of the blade. The saw comes with a push stick but you can also make one (see **WORK HELPERS** on page 10).

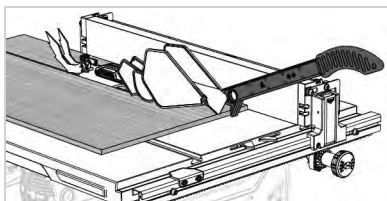

i NOTE:

Your saw includes a storage holder specifically for the included push stick when it is not in use. See your owner's manual for model-specific details on the location of the holder. For stationary saws equipped with the optional T-Glide Fence system (not available in the EU), the push stick can also rest safely on top of the fence between uses.

! WARNING:

Do NOT use the miter gauge when making rip cuts.
The blade guard should be used for all through cuts.

Cross Cut

A cross cut is created by cutting across the grain of the workpiece.



Always use the miter gauge (C) when cutting across the grain. As shown in the illustration, the grain direction (D) is essentially perpendicular to the cut. This applies even if the miter gauge is not set to 90°.

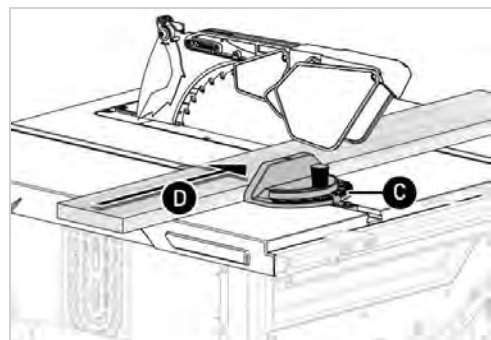

! WARNING:

When cross-cutting round stock it is necessary to secure the work-piece against rotation by using a suitable jig or holder. Use a suitable saw blade for the material being cut.

1. Tilt the blade to the desired bevel angle as needed, and then adjust the blade elevation to about 1/8" to 1/4" (3 to 6 mm) higher than the workpiece.

- Place the miter gauge in the right-hand miter slot for bevel cuts, or in either the right-hand or left-hand miter slots for non-bevel cuts.
- Adjust the miter gauge as needed by loosening the locking knob (B).



- Pivot the miter gauge (C) to the desired angle, and then tighten the locking knob.



! WARNING:

Set the blade elevation only as high as necessary to make a cut. (Only slightly above than the thickness of the workpiece is sufficient.)

- Make sure the workpiece is not touching the blade.** With the power switch on, pull the Start/Stop paddle to spin the blade.
- Hold the workpiece squarely and firmly against the miter gauge face and table. Push the workpiece slowly and smoothly toward and past the blade.
- For through-cuts, shift the workpiece slightly away from the blade before pulling the miter gauge and workpiece back toward the front of saw. Do NOT touch the cut-off portion of the workpiece until the blade has stopped.

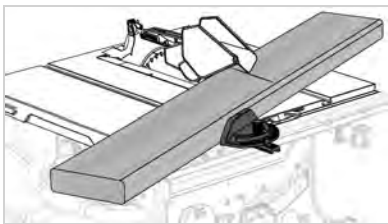

! WARNING:

Do not use the miter gauge in the slot on the left of the blade when making bevel cuts.

between the blade and any conductive surfaces to avoid any chance of the activation of the SawStop safety system.

You can also attach a user provided extension to the included miter gauge, making the effective contact face wider.

! WARNING:

Always remove the rip fence from the table when making cuts with the miter gauge. If the workpiece contacts the rip fence during a crosscut, the workpiece could deflect and bind, resulting in kickback.

Bevel Cut

A bevel cut is created by beveling the blade. In this example, a bevel has been included with a cross cut.

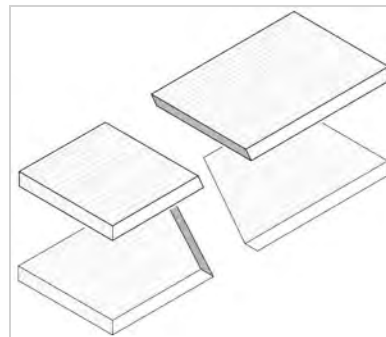

! WARNING:

To reduce the likelihood of kickback when making beveled rip cuts (parallel to the grain of the workpiece) position the rip fence only on the right-hand side of the blade. The waste portion of the workpiece left under the slope of the blade after cutting is then free to move out of the potential pinch zone.

! WARNING:

When making beveled cross cuts, use the miter gauge in the right-hand miter slot only.

Remove the rip fence when making cross cuts.

Molding head cutting is not permitted.

If using an extruded aluminum or other metal miter fence attachment, be sure to maintain a gap of at least 1/8" (3mm)

**WARNING:**

Tapered cuts are permissible, but are only to be performed with the proper fixture.

Non-Through Cut**WARNING:**

When creating a through cut that does not pass through the entire length of the workpiece, always

- 1.) press the Start/Stop paddle
- 2.) turn off power to the saw, and then
- 3.) remove the workpiece.

Only remove the workpiece when the blade has come to a complete stop. If the blade is still spinning, the workpiece may kickback.

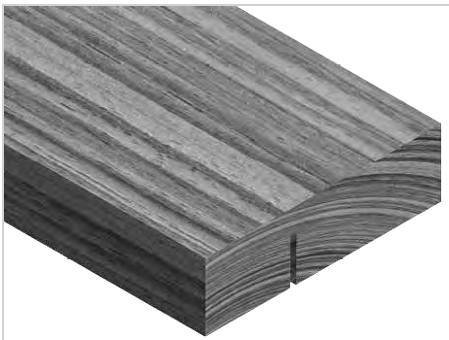

A non-through cut does not extend through the entire thickness of the workpiece. A groove cut, shown here, is a type of non-through cut as parallel to the grain.

You cannot use a spreader mounted blade guard* with a non-through cut but must use the riving knife (A) instead.

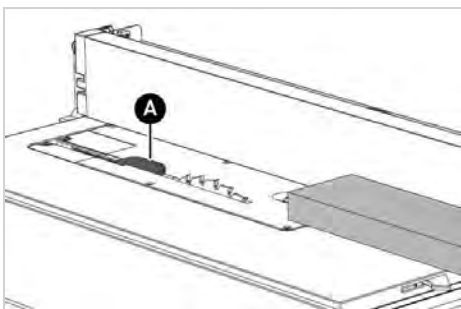

1. Remove the blade guard*, and then install the riving knife. If a rip cut, use the rip fence. If a cross cut, use the miter gauge, and remove the rip fence from the table. (See your model-specific owner's manual for detailed instructions.)
2. Adjust the blade elevation to desired cut depth.

3. **Make sure the workpiece is not touching the blade.** With the power switch on, pull the Start/Stop paddle to spin the blade.
4. Hold the workpiece squarely and firmly against the face of the rip fence, or miter gauge, and table. Push the workpiece slowly and smoothly toward and past the blade.
5. When non-through cut work is complete, remove the riving knife and re-install the factory blade guard.

Use a push stick or push block to safely cut the workpiece.

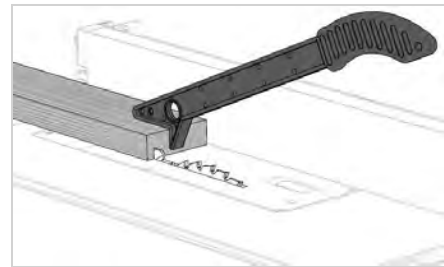
**NOTE:**

* While spreader mounted blade guards cannot be used for grooving / dado operations, an auxiliary guard such as the SawStop Floating Dust Collector or a shop built horizontal fence as shown here can be used to add a measure of safety.

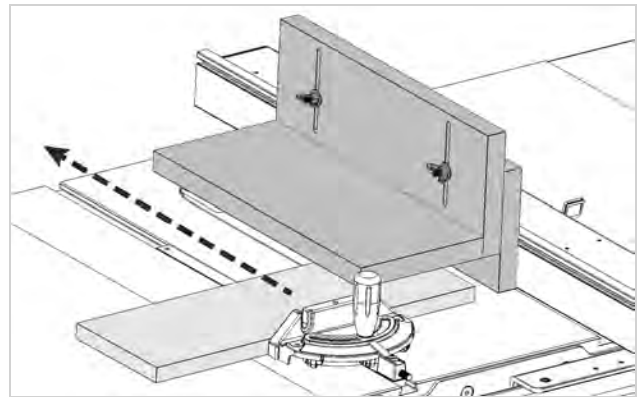

Plunge Cut

A plunge cut is used to create a slot or opening somewhere other than the edge of the workpiece.

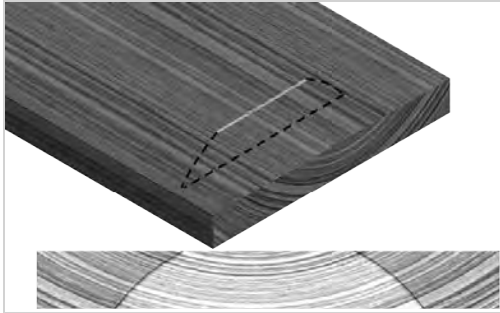

WARNING:

Use extra caution when making plunge cuts, since the blade guard, riving knife*, and anti-kickback pawls cannot be used. Do not use the riving knife.

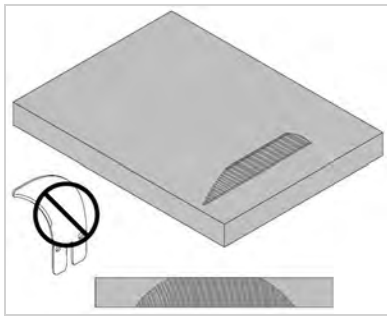

1. Fully lower the blade. If the riving knife* is installed, remove the riving knife.
2. Clamp a support board (A) to the rip fence. Place the workpiece against the support board and set the rip width. Place a featherboard (B) firmly against the top of the workpiece, and then clamp to the support board. Place another featherboard (C) firmly against the side of the workpiece, and then clamp the featherboard to the table. Make sure the horizontal featherboard is in front of the blade such that the featherboard is NOT applying pressure to the cut.

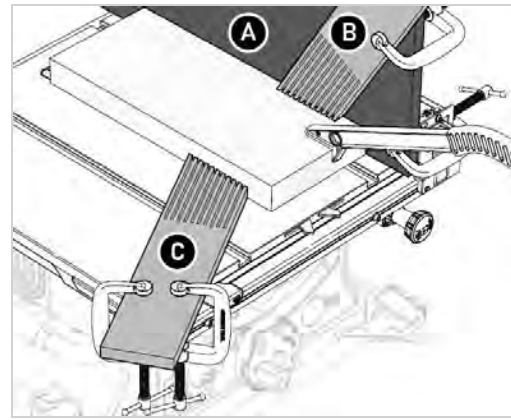

3. Raise the blade to the desired height or depth of cut (D).

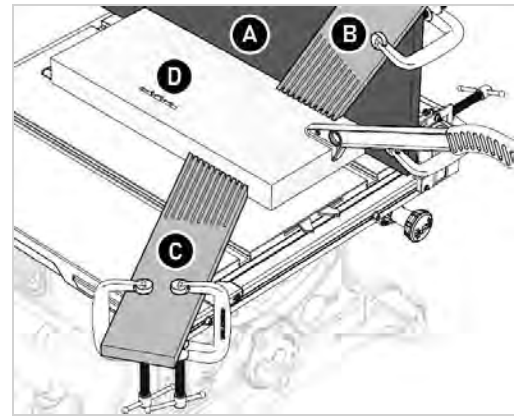

4. Finish the cut, as needed.
5. When non-through cut work is complete, re-install the factory blade guard or riving knife* before continuing to use the saw.

If making a non-through cut, press the Start/Stop paddle and let the blade come to a complete stop. Turn off power to the saw, and then remove the featherboards and support board. Remove the workpiece.

WARNING:

To avoid kickback with a non-through cut, never remove the workpiece while the blade is spinning.

WARNING:

To avoid kickback, always keep the horizontal featherboard (C) in front of the blade, such that the featherboard won't put pressure against the side of the blade.

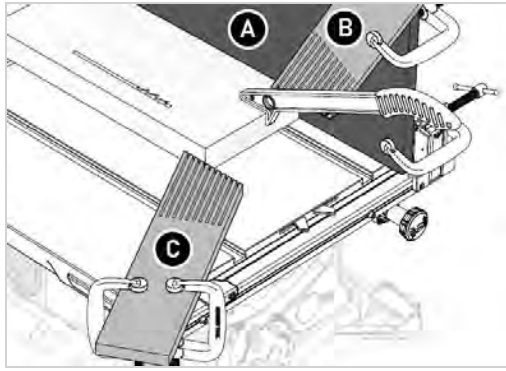

NOTE:

* The riving knife is an optional accessory available for purchase through the online SawStop parts store. If you purchased your saw configured with the Floating Dust Collection Guard (TSG-FDC), a 10" / 254mm blade compatible riving knife is provided.

Grooving Cut

Grooving removes areas of material so a workpiece can be bent or shaped.



1. Remove the blade guard and install the riving knife*.
2. Adjust the blade elevation to the desired cut depth. Remove the rip fence from the table.
3. Mount a wood face extension to the miter gauge, as needed. Install the miter gauge in the miter slot, making sure the wood face extends across blade (so a single cut will be made in the face).
4. **Make sure the workpiece is not touching the blade.** With the power switch on, pull the Start/Stop paddle to spin the blade.
5. Make a series of evenly spaced cuts along the workpiece, moving the workpiece over slightly between each cut.

6. As needed, flip the workpiece over and make another series of cuts, offset from the first set, using the same method.

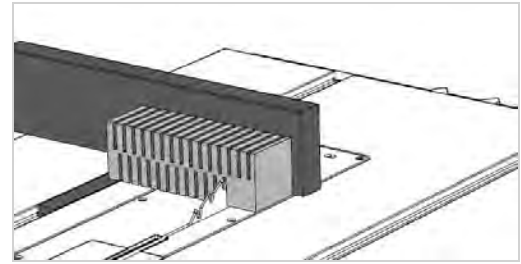

7. When grooving cut work is complete, remove the riving knife and re-install the factory blade guard before continuing to use the saw.

WARNING:

Use extra caution when not using the blade guard.

NOTE:

* The riving knife is an optional accessory available for purchase through the online SawStop parts store. If you purchased your saw configured with the Floating Dust Collection Guard (TSG-FDC), a 10" / 254mm blade compatible riving knife is provided.

Rabbet (Rebate) Cut

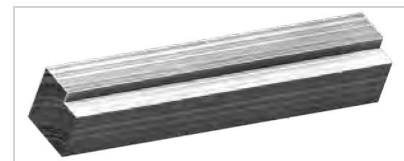

A rabbet (rebate) cut is a rectangular recess along the edge or end of a workpiece. Dado blades are incompatible with SawStop portable saw models (CTS and JSS Pro) but you can use multiple passes, as needed, to create a rabbet (rebate) cut. You must use featherboards when making a rabbet (rebate) rip cut, similar to the illustrations in the Plunge Cut section.

