

metabo®

PROFESSIONAL POWER TOOL SOLUTIONS

SSW 18 LTX 400 BL
SSW 18 LTX 400 BL SE
SSW 18 LTX 600
SSW 18 LTX 800 BL
SSW 18 LTX 1450 BL
SSW 18 LTX 1750 BL



de Originalbetriebsanleitung 5
en Original instructions 9
fr Notice originale 13
nl Oorspronkelijke gebruiksaanwijzing 17
it Istruzioni originali 21
es Manual original 25
pt Manual original 29
sv Bruksanvisning i original 33

fi Alkuperäiset ohjeet 37
no Original bruksanvisning 41
da Original brugsanvisning 45
pl Instrukcja oryginalna 49
el Πρωτότυπο οδηγιών χρήσης 53
hu Eredeti használati utasítás 58
ru Оригинальное руководство по эксплуатации 62
uk Оригінальна інструкція з експлуатації 67

SSW 18 LTX 1750 BL
SSW 18 LTX 1450
SSW 18 LTX 800 BL





SSW 18 LTX 400 BL

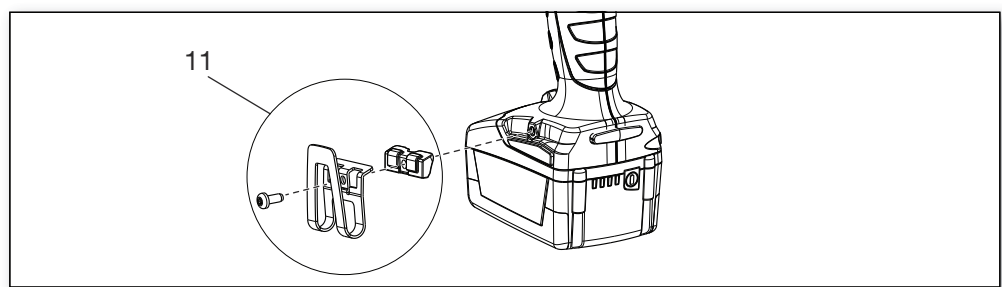
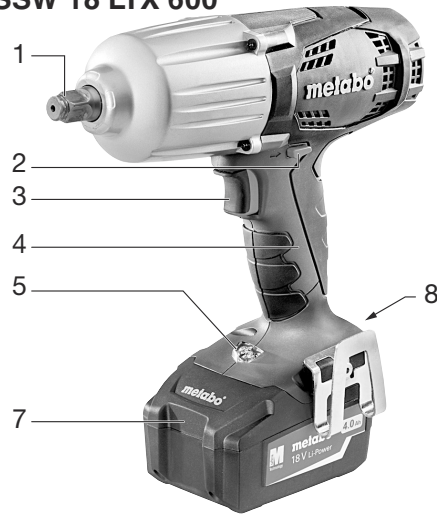

SSW 18 LTX 600

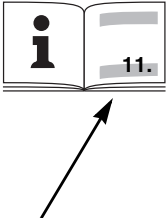

		SSW 18 LTX 400 BL <small>*1) Serial Number: 02205..</small>	SSW 18 LTX 400 BL SE <small>*1) Serial Number: 02255..</small>	SSW 18 LTX 600 <small>*1) Serial Number: 02198..</small>	SSW 18 LTX 800 BL <small>*1) Serial Number: 02403..</small>	SSW 18 LTX 1450 BL <small>*1) Serial Number: 02401..</small>	SSW 18 LTX 1750 BL <small>*1) Serial Number: 02402..</small>
		U	V	18	18	18	18
n_0	/min, rpm	0-2150	0-1600	0-2575	0-1500	0-1650	
S	/min, bpm	4250	2200	3300	2250	2450	
H	-	<input type="checkbox"/> 1/2" (12,7 mm)	<input type="checkbox"/> 1/2" (12,7 mm)	<input type="checkbox"/> 1/2" (12,7 mm)	<input type="checkbox"/> 1/2" (12,7 mm)	<input type="checkbox"/> 3/4" (19 mm)	
m	kg (lbs)	1,9 (4.2)	3,1 (6.9)	2,6 (5.7)	3,9 (8.6)	4,0 (8.8)	
$M_{max.}$	Nm (in- lbs)	400 (3540)	600 (5310)	800 (7080)	1450 (12833)	1750 (15489)	
a_h / K_h	m/s ²	12,0 / 1,5	11,0 / 1,5	10,7 / 1,5	16 / 1,5	16,4 / 1,5	
L_{pA} / K_{pA}	dB(A)	100 / 3	92 / 3	96 / 3	96 / 5	97 / 5	
L_{WA} / K_{WA}	dB(A)	111 / 3	103 / 3	107 / 3	107 / 5	108 / 5	

 *2) 2014/30/EU, 2006/42/EC, 2011/65/EU
 *3) EN 62841-1:2015, EN 62841-2-2:2014, EN IEC 63000:2018

2021-09-15 Bernd Fleischmann *ppa. B.F.*
 Direktor Produktentstehung & Qualität (Vice President Product Engineering & Quality)
 *4) Metabowerke GmbH - Metabo-Allee 1 - 72622 Nuertingen, Germany

(A)



ASC 145, ASC 145 Duo und ASC 55 etc.

(B)



18 V	3,0 Ah	6.25594	SSW 18 LTX 400, 400 SE, 600, 800
18 V	4,0 Ah	6.25591	
18 V	5,2 Ah	6.25592	
18 V	5,5 Ah	6.25368	
18 V	8,0 Ah	6.25369	
18 V	10,0 Ah	6.25549	
.....	etc.	SSW 18 LTX 1450/1750 BL

(C)

1/2"

3/4"



6.28829

1/2"



6.28836

1/4"



6.28849

6.28850

(D)



6.28831



6.28832

Original instructions

1. Declaration of Conformity

We hereby declare under our sole responsibility that these cordless impact drivers, identified by type and serial number *1), meet all relevant requirements of directives *2) and standards *3). Technical documents for *4) - see page 3.

For UK only:

UK We as manufacturer and authorized person to
CA compile the technical file, see *4) on page 3, hereby declare under sole responsibility that these cordless impact wrench, identified by type and serial number *1) on page 3, fulfill all relevant provisions of following UK Regulations S.I. 2016/1091, S.I. 2008/1597, S.I. 2012/3032 and Designated Standards EN 62841-1:2015,

2. Specified Conditions of Use

The impact driver is suitable for driving in and removing screws.

The user bears sole responsibility for any damage caused by inappropriate use.

Generally accepted accident prevention regulations and the enclosed safety information must be observed.

3. General Safety Information



For your own protection and for the protection of your power tool, pay attention to all parts of the text that are marked with this symbol!



WARNING – Read the operating instructions to reduce the risk of injury.



WARNING – Read all safety warnings, instructions, illustrations and specifications provided with this power tool. Failure to follow all instructions listed below may result in electric shock, fire and/or serious injury.

Keep all safety instructions and information for future reference.

Always include these documents when passing on your power tool.

4. Special safety instructions

Hold the power tool by insulated gripping surfaces, when performing an operation where the fastener may contact hidden wiring.

Fasteners contacting a "live" wire may make exposed metal parts of the power tool "live" and could give the operator an electric shock.

Remove the battery pack from the machine before making any adjustments, changing tools, maintaining or cleaning.

Make sure that the tool is switched off before fitting the battery pack.

Ensure that the spot where you wish to work is free of **power cables, gas lines or water pipes** (e.g. using a metal detector).

Secure the workpiece to prevent slipping or rotation (e.g. by securing with screw clamps).



Protect battery packs from water and moisture!



Do not expose battery packs to fire!

Do not use faulty or deformed battery packs!

Do not open battery packs!

Do not touch or short circuit battery pack contacts!



A slightly acidic, flammable fluid may leak from defective Li-ion battery packs!



If battery fluid leaks out and comes into contact with your skin, rinse immediately with plenty of water. If battery fluid leaks out and comes into contact with your eyes, wash them with clean water and seek medical attention immediately!

If the machine is defective, remove the battery pack from the machine.

Only screwdriving bits suitable for the impact drivers must be used.

Take care when driving in long screws - risk of slipping.

Mount the machine on the screw only when it is switched off.

Wear ear protectors when working for long periods of time. High noise levels over a prolonged period of time may affect your hearing.



CAUTION Do not stare at operating lamp (5).

Risk of burning! The aluminium housing can get very hot during use. Risk of burning! Leave a hot aluminium housing cool down. Do not clean the housing with flammable liquids.

Transport of li-ion battery packs:

The shipping of li-ion battery pack is subject to laws related to the carriage of hazardous goods (UN 3480 and UN 3481). Inform yourself of the currently valid specifications when shipping li-ion battery packs. If necessary, consult your freight forwarder. Certified packaging is available from Metabo.

Only send the battery pack if the housing is intact and no fluid is leaking. Remove the battery pack from the machine for sending. Prevent the contacts from short-circuiting (e.g. by protecting them with adhesive tape).

Reducing dust exposure:



WARNING - Some dust created by power sanding, sawing, grinding, drilling, and other construction activities contains chemicals known to cause cancer, birth defects or other reproductive harm. Some examples of these chemicals are:

- Lead from lead-based paints,

- Crystalline silica from bricks and cement and other masonry products, and
- Arsenic and chromium from chemically treated lumber.

Your risk from these exposures varies, depending on how often you do this type of work. To reduce your exposure to these chemicals: work in a well-ventilated area, and work with approved safety equipment, such as those dust masks that are specially designed to filter out microscopic particles.

This also applies to dust from other materials such as some timber types (like oak or beech dust), metals, asbestos. Other known diseases are e.g. allergic reactions, respiratory diseases. Do not let dust enter the body.

Observe the relevant guidelines and national regulations for your material, staff, application and place of application (e.g. occupational health and safety regulations, disposal).

Collect the particles generated at the source, avoid deposits in the surrounding area.

Use suitable accessories for special work. In this way, fewer particles enter the environment in an uncontrolled manner.

Use a suitable extraction unit.

Reduce dust exposure with the following measures:

- do not direct the escaping particles and the exhaust air stream towards yourself or nearby persons or towards dust deposits,
- use an extraction unit and/or air purifiers,
- ensure good ventilation of the workplace and SWd keep it clean using a vacuum cleaner. Sweeping or blowing stirs up dust.
- Vacuum or wash protective clothing. Do not blow, beat or brush protective gear.

5. Overview

See page 2.

- 1 Square socket for bits
- 2 Rotation selector switch / Transporting safety device
- 3 Trigger
- 4 Handle (gripping surface)
- 5 LED light
For working in badly lit areas. The LED light lights up when the machine is switched on.
- 6 Thumbwheel for speed and tightening torque selection *
- 7 Battery pack
- 8 Battery pack release button
- 9 Button of capacity indicator
- 10 Capacity and signal indicator
- 11 Belt hook (attach as shown) *
- 12 Eyelet (for fall protection) *

* depending on the features / model

6. Initial Operation/Setting



Remove the battery pack from the machine before any adjustment or maintenance is carried out. Before fitting the battery pack, make sure that the machine is switched off.

6.1 Battery pack

For SSW 18 LTX 1450 BL and SSW 18 LTX 1750 BL the battery packs 1.5 Ah, 2.0 Ah, 3.0 Ah und LiHD 4.0 Ah **cannot** be used! The machine does not start!

We recommend the use of LiHD battery packs with a capacity of at least 5.5 Ah. If other battery packs are used, a reduced performance is to be expected.

Charge the battery pack (7) before use.

Recharge the battery pack if performance diminishes.

Instructions on charging the battery pack can be found in the operating instructions of the Metabo charger.

Li-ion battery packs “Li-Power“ have a capacity and signal indicator (10):

- Press the button (9), the LEDs indicate the charge level.
- The battery pack is almost flat and must be recharged if one LED is flashing.

Removing:

Press the battery pack release button (8) and pull the battery pack (7) **forwards**.

Inserting:

Slide in the battery pack (7) until it engages.

6.2 Setting the direction of rotation, engaging the transporting safety device (switch-on lock)



Only operate the rotation selector switch / transporting safety device (2) when the motor is at standstill!

Actuate the rotation selector switch / Engage the transportation lock (2).

- R** = Clockwise setting (drive in screws)
- L** = Anti-clockwise setting (undo screws)
- 0** = middle position: transportation safety device (SSWswitch-on lock) set

6.3 Switching on and off

Switching on: press the trigger switch (3).

Switching off: Release the trigger (3).

6.4 Speed / tightening torque

The speed and tightening torque are connected directly. The lower the speed, the lower the tightening torque.

The tightening torque is influenced in two ways:

1) Depending on the configuration, preselect operating mode/desired tightening torque at the setting wheel (6):

MAX = max. tightening torque (power mode)

1..10 = adjustable tightening torque

APS = automatic speed control (automatic power shift):

Loosening: Prevents the screw/nut from falling by means of automatic speed reduction after loosening.

Screwing: Prevents overtightening of the screw/nut by means of automatic deactivation after the first impact.

2) Stepless adjustment of the tightening torque:

The speed and tightening torque can be adjusted steplessly in any position of the setting wheel by pressing the trigger (3) firmly or lightly, thus adapting to working conditions.

Recommendation: determine the correct setting by carrying out trial screwdriving.

6.5 Change screwdriving bit for SSW ...

Inserting screwdriving bit: Fit the tool on the square attachment (1) until the limit stop.

Removing screwdriving bit: Pull the tool from the square attachment (1).

 The screwdriving bit used must match the screw.

 Damaged screwdriving bits must not be used.

7. Use

Mount the machine on the screw, ensuring it is aligned straight.

The screwdriving process consists of 2 parts: **insert screw** and **tighten screw with the impact mechanism**.

The tightening torque depends on the impact duration.

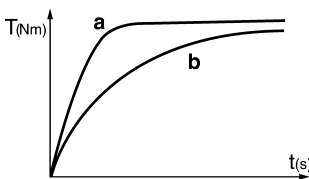

With an impact duration of approx. 5 seconds, the maximum tightening torque has been reached.

The torque curve depends on the type of application:

With a hard screwdriving application (screw-couplings in hard material such as metal), maximum tightening torque is already reached after a short impact duration (a).

With a soft screwdriving application (screw-couplings in soft material such as wood), a longer impact duration (b) is required.

Recommendation: determine the correct impact duration by carrying out trial screwdriving.

Caution! For **small screws** the maximum torque can be reached already after 0.5 seconds impact duration.

- This is why the duration of the screwdriving process must be monitored exactly.
- Adjust the tightening torque by pressing firmly or lightly on the trigger (3), ensuring that the screw is not damaged or that the screw head does not tear off.

Eyelet for fall protection

 -The eyelet (12) is designed for attaching a suitable, original Metabo tool fall protection securing lanyard. Check the eyelet for damage prior to each use. Read and follow the operating instructions of the tool securing lanyard! After each fall, have the machine checked for damage by a trained specialist and repaired if necessary.

8. Accessories

Use only original Metabo or CAS (Cordless Alliance System) battery packs and accessories.

Use only accessories that fulfil the requirements and specifications listed in these operating instructions.

See page 4.

- A Chargers:
- B Battery packs with different capacities
Use only battery packs with voltage suitable for your power tool.
- C Screwdriving bits
- D Tool 1/2" / 3/4"

For a complete range of accessories, see www.metabo.com or the catalogue.

9. Repairs

 Repairs to electrical tools must **ONLY** be carried out by qualified electricians!

Contact your local Metabo representative if you have Metabo power tools requiring repairs. For addresses see www.metabo.com.

You can download a list of spare parts from www.metabo.com.

10. Environmental Protection

Observe national regulations on environmentally compatible disposal and on the recycling of disused machines, packaging and accessories.

Packaging materials must be disposed of according to their labelling in accordance with municipal guidelines. Further information can be found at www.metabo.com in the "Service" section.

Battery packs may not be disposed of with regular waste. Return faulty or used battery packs to your Metabo dealer!

Do not allow battery packs to come into contact with water!



Only for EU countries: never dispose of power tools in your household waste! According to European Directive 2012/19/EU on Waste from Electric and Electronic Equipment and implementation in national law, used power tools must be collected separately and recycled in an environmentally-friendly manner. Discharge the battery pack in the power tool before disposal. Prevent the contacts from short-circuiting (e.g. by protecting them with adhesive tape).

11. Technical Specifications

Explanatory notes on the specifications on page 3.

Changes due to technological progress reserved.

U = Voltage of battery pack

n_0 = No-load speed

S = impact frequency

H = machine tool holder

m = weight (with the smallest battery pack)

$M_{max.}$ = Max. tightening torque

Measured values determined in conformity with EN 62841.

Permitted ambient temperature during operation:

-20 °C to 50 °C (limited performance with temperatures below 0 °C). Permitted ambient temperature for storage: 0 °C to 30 °C

== direct current

The technical specifications quoted are subject to tolerances (in compliance with relevant valid standards).



Emission values

These values make it possible to assess the emissions from the power tool and to compare different power tools. The actual load may be higher or lower depending on operating conditions, the condition of the power tool or the accessories used. Please allow for breaks and periods when the load is lower for assessment purposes. Arrange protective measures for the user, such as organisational measures based on the adjusted estimates.

Vibration total value (vector sum of three directions) determined in accordance with EN 62841:

a_h = Vibration emission value (screwdriving with impact)

K_h = uncertainty (vibration)

Typical A-weighted sound levels:

L_{pa} = sound-pressure level

L_{WA} = acoustic power level

K_{pA} , K_{WA} = Uncertainty (noise level)



Wear ear protectors!