

PowerMaxx SSD 12 PowerMaxx SSD 12 BL





en Operating Instructions 5
fr Mode d'emploi 10

es Instrucciones de manejo 16

PowerMaxx SSD 12

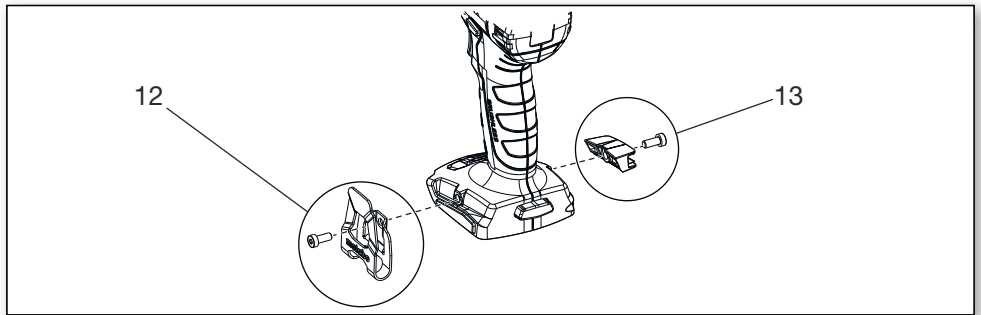
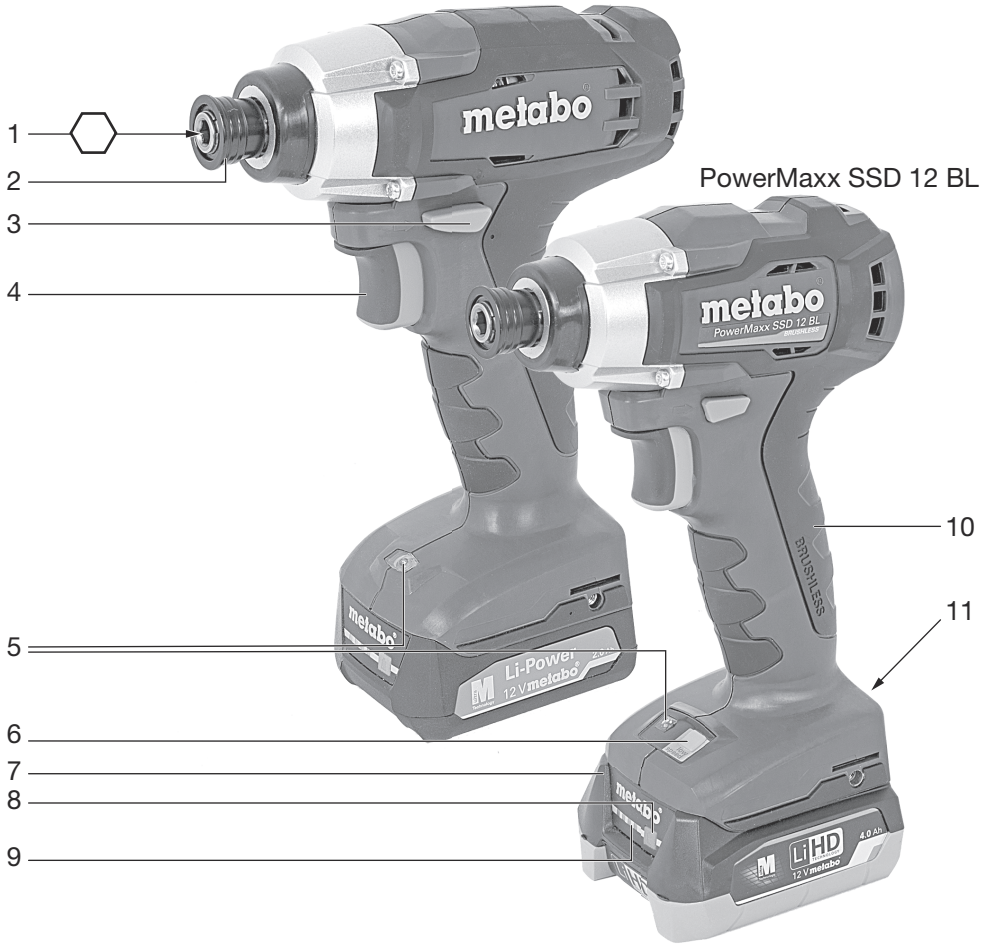
PowerMaxx SSD 12 BL

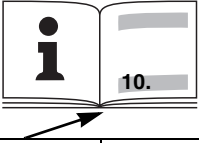

		PowerMaxx SSD 12 Serial Number: 01114...	PowerMaxx SSD 12 BL Serial Number: 01115...
U	V	12	
n₀	/min, rpm	0 - 2500	0 - 1250 / 0 - 2500
S	/min, bpm	0 - 3500	0 - 2000 / 0 - 4000
H	-	 1/4" (6,35 mm)	
m	lbs (kg)	2.4 (1,1)	2.2 (1,0)
M_{max}	in-lbs (Nm)	1015 (115)	620 (70) / 1240 (140)
a_h / K_h	m/s²	16 / 1,5	20 / 1,5
L_{pA} / K_{pA}	dB(A)	95 / 5	96 / 5
L_{WA} / K_{WA}	dB(A)	105 / 5	105 / 5

Metabowerke GmbH,
 Postfach 1229
 Metabo-Allee 1
 D-72622 Nuertingen
 Germany

(A)



ASC ultra

etc.

(B)



12V	2,0 Ah	6.25406	Li-Power
12V	4,0 Ah	6.25349	LiHD

etc.

(C)

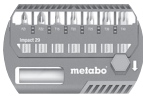

6.28849



6.28850



etc.



6.28838



Operating Instructions

1. Specified Conditions of Use

The impact driver is suitable for driving in and removing screws.

The user bears sole responsibility for any damage caused by inappropriate use.

Generally accepted accident prevention regulations and the enclosed safety information must be observed.

2. General Safety Information



For your own protection and for the protection of your power tool, pay attention to all parts of the text that are marked with this symbol!



WARNING – Reading the operating instructions will reduce the risk of injury.

Pass on your power tool only together with these documents.

General Power Tool Safety Warnings



WARNING – Read all safety warnings, instructions, illustrations and specifications provided with this power tool. Failure to follow all instructions listed below may result in electric shock, fire and/or serious injury.

Save all safety warnings and information for future reference! The term "power tool" in the safety warnings refers to your mains-operated (corded) power tool or battery-operated (cordless) power tool.

2.1 Work area safety

- Keep work area clean and well lit.** Cluttered or dark areas invite accidents.
- Do not operate power tools in explosive atmospheres, such as in the presence of flammable liquids, gases or dust.** Power tools create sparks which may ignite the dust or fumes.
- Keep children and bystanders away while operating a power tool.** Distractions can cause you to lose control.

2.2 Electrical safety

- Power tool plugs must match the outlet. Never modify the plug in any way. Do not use any adapter plugs with earthed (grounded) power tools.** Unmodified plugs and matching outlets will reduce risk of electric shock.
- Avoid body contact with earthed or grounded surfaces, such as pipes, radiators, ranges and refrigerators.** There is an increased risk of electric shock if your body is earthed or grounded.
- Do not expose power tools to rain or wet conditions.** Water entering a power tool will increase the risk of electric shock.

- Do not abuse the power tool. Never use the cord for carrying, pulling or unplugging the power tool. Keep cord away from heat, oil, sharp edges or moving parts.** Damaged or entangled cords increase the risk of electric shock.
- When operating a power tool outdoors, use an extension cord suitable for outdoor use.** Use of a cord suitable for outdoor use reduces the risk of electric shock.
- If operating a power tool in a damp location is unavoidable, use a residual current device (RCD) protected supply.** Use of an RCD reduces the risk of electric shock.

2.3 Personal safety

- Stay alert, watch what you are doing and use common sense when operating a power tool. Do not use a power tool while you are tired or under the influence of drugs, alcohol or medication.** A moment of inattention while operating power tools may result in serious personal injury.
 - Use personal protective equipment. Always wear eye protection.** Protective equipment such as a dust mask, non-skid safety shoes, hard hat or hearing protection used for appropriate conditions will reduce personal injuries.
 - Prevent unintentional starting. Ensure the switch is in the off-position before connecting to power source and/or battery pack, picking up or carrying the tool.** Carrying power tools with your finger on the switch or energising power tools that have the switch on invites accidents.
 - Remove any adjusting key or wrench before turning the power tool on.** A wrench or a key left attached to a rotating part of the power tool may result in personal injury.
 - Do not overreach. Keep proper footing and balance at all times.** This enables better control of the power tool in unexpected situations.
 - Dress properly. Do not wear loose clothing or jewellery. Keep your hair, clothing and gloves away from moving parts.** Loose clothes, jewellery or long hair can be caught in moving parts.
 - If devices are provided for the connection of dust extraction and collection facilities, ensure these are connected and properly used.** Use of dust collection can reduce dust-related hazards.
 - Do not let familiarity gained from frequent use of tools allow you to become complacent and ignore tool safety principles.** A careless action can cause severe injury within a fraction of a second.
- ### 2.4 Power tool use and care
- Do not force the power tool. Use the correct power tool for your application.** The correct power tool will do the job better and safer at the rate for which it was designed.
 - Do not use the power tool if the switch does not turn it on and off.** Any power tool that cannot

be controlled with the switch is dangerous and must be repaired.

c) **Disconnect the plug from the power source and/or remove the battery pack, if detachable, from the power tool before making any adjustments, changing accessories, or storing power tools.** Such preventive safety measures reduce the risk of starting the power tool accidentally.

d) **Store idle power tools out of the reach of children and do not allow persons unfamiliar with the power tool or these instructions to operate the power tool.** Power tools are dangerous in the hands of untrained users.

e) **Maintain power tools and accessories with care. Check for misalignment or binding of moving parts, breakage of parts and any other condition that may affect the power tool's operation. If damaged, have the power tool repaired before use.** Many accidents are caused by poorly maintained power tools.

f) **Keep cutting tools sharp and clean.** Properly maintained cutting tools with sharp cutting edges are less likely to bind and are easier to control.

g) **Use the power tool, accessories and tool bits etc. in accordance with these instructions, taking into account the working conditions and the work to be performed.** Use of the power tool for operations different from those intended could result in a hazardous situation.

h) **Keep handles and grasping surfaces dry, clean and free from oil and grease.** Slippery handles and grasping surfaces do not allow safe handling and control of the tool in unexpected situations.

2.5 Battery tool use and care

a) **Recharge only with the charger specified by the manufacturer.** A charger that is suitable for one type of battery pack may create a risk of fire when used with another battery pack.

b) **Use power tools only with specifically designated battery packs.** Use of any other battery packs may create a risk of injury and fire.

c) **When battery pack is not in use, keep it away from other metal objects, like paper clips, coins, keys, nails, screws or other small metal objects, that can make a connection from one terminal to another.** Shorting the battery terminals together may cause burns or a fire.

d) **Under abusive conditions, liquid may be ejected from the battery; avoid contact. If contact accidentally occurs, flush with water. If liquid contacts eyes, additionally seek medical help.** Liquid ejected from the battery may cause irritation or burns.

e) **Do not use a battery pack or tool that is damaged or modified.** Damaged or modified batteries may exhibit unpredictable behaviour resulting in fire, explosion or risk of injury.

f) **Do not expose a battery pack or tool to fire or excessive temperature.** Exposure to fire or temperature above 130 °C (265 °F) may cause explosion.

g) **Follow all charging instructions and do not charge the battery pack or tool outside the temperature range specified in the instructions.** Charging improperly or at temperatures outside the specified range may damage the battery and increase the risk of fire.

2.6 Service

a) **Have your power tool serviced by a qualified repair person using only identical replacement parts.** This will ensure that the safety of the power tool is maintained.

b) **Never service damaged battery packs.** Service of battery packs should only be performed by the manufacturer or authorized service providers.

3. Special Safety Instructions

Hold the power tool by insulated gripping surfaces, when performing an operation where the fastener may contact hidden wiring.

Fasteners contacting a "live" wire may make exposed metal parts of the power tool "live" and could give the operator an electric shock.

Remove the battery pack from the machine before making any adjustments, changing tools, maintaining or cleaning.

Make sure that the tool is switched off before fitting the battery pack.

Ensure that the spot where you wish to work is free of **power cables, gas lines or water pipes** (e.g. using a metal detector).

Secure the workpiece to prevent slipping or rotation (e.g. by securing with screw clamps).

 Protect battery packs from water and moisture!

 Do not expose battery packs to fire!

 Do not use faulty or deformed battery packs!

Do not open battery packs!

Do not touch or short circuit battery pack contacts!

 A slightly acidic, flammable fluid may leak from defective Li-ion battery packs!

 If battery fluid leaks out and comes into contact with your skin, rinse immediately with plenty of water. If battery fluid leaks out and comes into contact with your eyes, wash them with clean water and seek medical attention immediately!

If the machine is defective, remove the battery pack from the machine.

Only screwdriving bits suitable for the impact drivers must be used.

Take care when driving in long screws - risk of slipping.

Mount the machine on the screw only when it is switched off.

Wear ear protectors.

Materials that generate dusts or vapours that may be harmful to health (e.g. asbestos) must not be processed.

LED light (5): do not observe the LED radiation directly with optical instruments.



CAUTION Do not stare at operating lamp.

Additional Warnings:

⚠ WARNING Some dust created by power sanding, sawing, grinding, drilling, and other construction activities contains chemicals known to cause cancer, birth defects or other reproductive harm. Some examples of these chemicals are:

- Lead from lead-based paints,
- Crystalline silica from bricks and cement and other masonry products, and
- Arsenic and chromium from chemically treated lumber.

Your risk from these exposures varies, depending on how often you do this type of work. To reduce your exposure to these chemicals: work in a well ventilated area, and work with approved safety equipment, such as those dust masks that are specially designed to filter out microscopic particles.

Transport of li-ion battery packs:

The shipping of li-ion battery pack is subject to laws related to the carriage of hazardous goods (UN 3480 and UN 3481). Inform yourself of the currently valid specifications when shipping li-ion battery packs. If necessary, consult your freight forwarder. Certified packaging is available from Metabo.

Only send the battery pack if the housing is intact and no fluid is leaking. Remove the battery pack from the machine for sending. Prevent the contacts from short-circuiting (e.g. by protecting them with adhesive tape).

SYMBOLS

V volts

≡ direct current

n_0 rated speed

./min revolutions per minute

rpm revolutions per minute

4. Overview

See page 2. (sample figure)

- 1 Hexagon socket attachment for hexagon screwdriving bits
- 2 Locking sleeve
- 3 Rotation selector switch / Transporting safety device
- 4 Trigger
- 5 LED light
- 6 Button for speed/tightening torque preselection *

- 7 Battery pack *
- 8 Capacity indicator button *
- 9 Capacity and signal indicator *
- 10 Handle (gripping surface)
- 11 Battery pack release button
- 12 Belt hook (attach as shown) *
- 13 Bit depot (attach as shown) *

* depending on the features / model

5. Initial Operation/Setting

⚠ Remove battery pack from the machine before carrying out any setting, retrofitting, maintenance or cleaning. Ensure that the machine is switched off when the battery pack is switched off.

5.1 The machine's multifunctional monitoring system

⚠ If the machine switches off automatically, the machine electronics have activated automatic protection mode. A warning signal sounds (continuous beeping). The beeping stops after a maximum of 30 seconds or when the trigger switch (4) is released.

⚠ In spite of this protective function, overloading is still possible with certain applications and can result in damage to the machine.

Causes and remedies:

1. **Battery pack almost flat** (the electronics prevent the battery pack from discharging totally and avoid irreparable damage).
If the battery pack is almost flat, it must be recharged.
2. Long continuous overloading of the machine will activate the **temperature cut-out**.
Leave the machine or battery pack to cool.
Note: the machine will cool more quickly if you operate it at idling speed.

5.2 Battery pack

Charge the battery pack (7) before use. Charge the battery pack again if the performance drops.

Instructions on charging the battery pack can be found in the operating instructions of the Metabo charger.

Li-Ion battery packs “Li-Power, LiHD“ have a capacity and signal indicator (9):

- Press the button (8), the LEDs indicate the charge level.
- The battery pack is almost flat and must be recharged if one LED is flashing.

Removing:

Press the battery pack release button (11) and pull the battery pack (7) **forwards**.

Inserting:

Slide in the battery pack (7) until it engages.

5.3 Setting the direction of rotation, engaging the transporting safety device (switch-on lock)

 Only operate the rotation selector switch / transporting safety device (3) when the motor is at standstill!

Actuate the rotation selector switch / Engage the transportation lock (3).

- R = Clockwise setting (drive in screws)
- L = Anti-clockwise setting (undo screws)
- 0 = middle position: transportation safety device (Switch-on lock) set

5.4 Switching on and off

Switching on: press the trigger switch (4).

Switching off: Release the trigger (4).

5.5 Speed / tightening torque

The speed and tightening torque are connected directly. The lower the speed, the lower the tightening torque.

The tightening torque is influenced in the following ways:

1) Preselect maximum tightening torque (ONLY for PowerMax SSD 12 BL)

You can select between 2 speed/ tightening torque settings by pressing the button (6). The maximum tightening torques can be found in the table on page 3 (M_{max}).

Button (6) lights up to indicate which setting is selected.

- no lighting = max. speed / max. tightening torque
- permanent lighting = low speed / low tightening torque

2) Stepless adjustment of the tightening torque (for PowerMax SSD 12 and PowerMax SSD 12 BL)

The speed and tightening torque can be adjusted steplessly by pressing the trigger (4) firmly or lightly, thus adapting to working conditions.

Recommendation: determine the correct setting by carrying out trial screwdriving.

5.6 Changing the screwdriving bit

Inserting screwdriving bit: Slide locking sleeve (2) forward and insert screwdriving bit as far as the stop. Release locking sleeve (2).

 Pull on the screwdriver bit to check that it is correctly seated.

Removing screwdriving bit: Slide locking sleeve (2) forward and remove screwdriving bit.

 Only use screwdriving bits with such plug-in ends:

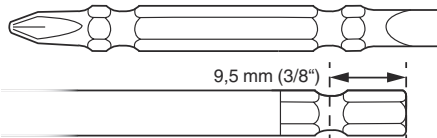

 The screwdriving bit used must match the screw.

 Damaged screwdriving bits must not be used.

6. Use

Mount the machine on the screw, ensuring it is aligned straight.

The screwdriving process consists of 2 parts: **insert screw** and **tighten screw with the impact mechanism**.

The tightening torque depends on the impact duration.

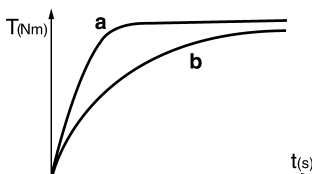

With an impact duration of approx. 5 seconds, the maximum tightening torque has been reached.

The torque curve depends on the type of application:

With a hard screwdriving application (screw-couplings in hard material such as metal), maximum tightening torque is already reached after a short impact duration (a).

With a soft screwdriving application (screw-couplings in soft material such as wood), a longer impact duration (b) is required.

Recommendation: determine the correct impact duration by carrying out trial screwdriving.

Caution! For **small screws** the maximum torque can be reached already after 0.5 seconds impact duration.

- This is why the duration of the screwdriving process must be monitored exactly.
- For PowerMax SSD 12 BL: Use button (6) to set a suitable level (see chapter 5.5).
- Adjust the tightening torque by pressing firmly or lightly on the trigger (4), ensuring that the screw is not damaged or that the screw head does not tear off.

7. Accessories

Use only original Metabo or CAS (Cordless Alliance System) battery packs and accessories.

Use only accessories that fulfil the requirements and specifications listed in these operating instructions.

See page 4.

- A Chargers
- B Battery packs with different capacities
Use only battery packs with voltage suitable for your power tool.
- C Screwdriving bits

For a complete range of accessories, see www.metabo.com or the catalogue.

8. Repairs



Repairs to electrical tools must ONLY be carried out by qualified electricians!

Contact your local Metabo representative if you have Metabo power tools requiring repairs. See www.metabo.com for addresses.

You can download a list of spare parts from www.metabo.com.

9. Environmental Protection

Observe national regulations on environmentally compatible disposal and on the recycling of disused machines, packaging and accessories.

Battery packs may not be disposed of with regular waste. Return faulty or used battery packs to your Metabo dealer!

Do not allow battery packs to come into contact with water!

10. Technical Specifications

Explanatory notes on the specifications on page 3.

Changes due to technological progress reserved.

U = voltage
(max. voltage = 12 V,
nominal voltage = 10.8 V)

n_0 = No-load speed

S = impact frequency

H = machine tool holder

m = weight (with the smallest battery pack)

M_{\max} = max. tightening torque

Permitted ambient temperature during operation: -20 °C bis 50 °C (limited performance with temperatures below 0 °C). Permitted ambient temperature for storage: 0 °C to 30 °C

The technical specifications quoted are subject to tolerances (in compliance with relevant valid standards).



Emission values

These values make it possible to assess the emissions from the power tool and to compare different power tools. The actual load may be higher or lower depending on operating conditions, the condition of the power tool or the accessories used. Please allow for breaks and periods when the load is lower for assessment purposes. Arrange protective measures for the user, such as

organisational measures based on the adjusted estimates.

Vibration total value (vector sum of three directions) determined in accordance with EN 62841:

a_h = Vibration emission value (screwdriving with impact)

K_h = Uncertainty (vibration)

Typical A-weighted sound levels:

L_{pa} = Sound-pressure level

L_{WA} = Acoustic power level

K_{pA} , K_{WA} = Uncertainty (noise level)



Wear ear protectors!