

**WEF 9-125 Quick**  
**WEPF 9-125 Quick**  
**WF 18 LTX 125 Quick**  
**WPF 18 LTX 125 Quick**

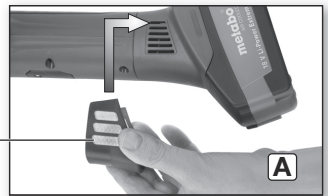

<b>de</b>	Originalbetriebsanleitung	5	<b>fi</b>	Alkuperäinen käyttöopas	67
<b>en</b>	Original instructions	13	<b>no</b>	Originalbruksanvisning	74
<b>fr</b>	Notice d'utilisation originale	20	<b>da</b>	Original brugsanvisning	81
<b>nl</b>	Oorspronkelijke gebruiksaanwijzing	28	<b>pl</b>	Instrukcja oryginalna	88
<b>it</b>	Istruzioni per l'uso originali	36	<b>el</b>	Πρωτότυπες οδηγίες λειτουργίας	96
<b>es</b>	Manual original	44	<b>hu</b>	Eredeti használati utasítás	105
<b>pt</b>	Manual original	52	<b>ru</b>	Оригинальное руководство по эксплуатации	113
<b>sv</b>	Bruksanvisning i original	60			

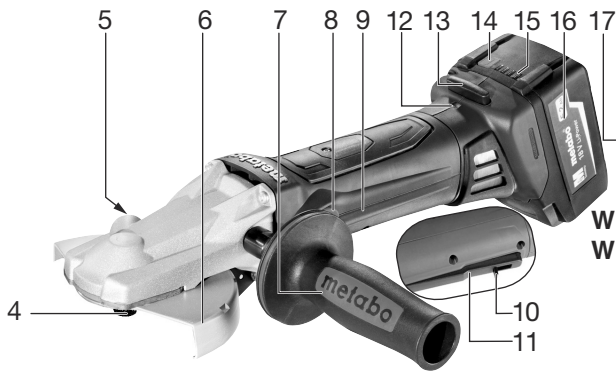



**WF 18 LTX 125 Quick**  
**WPF 18 LTX 125 Quick**

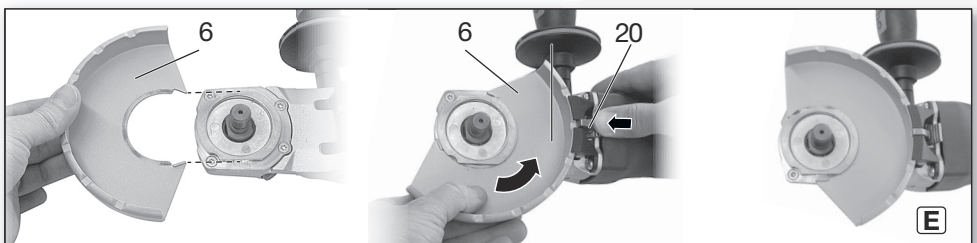
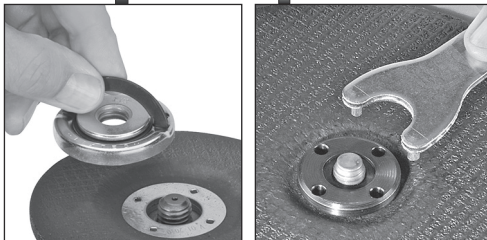
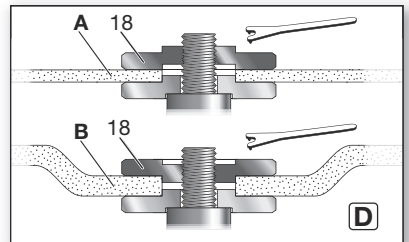
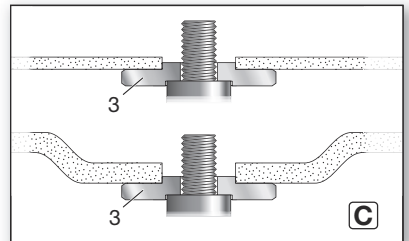
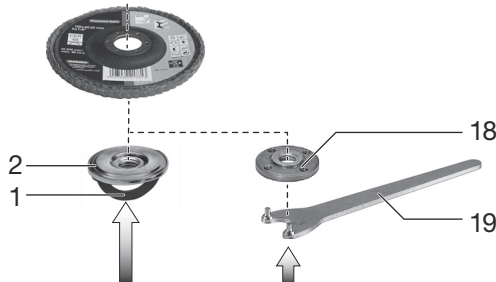
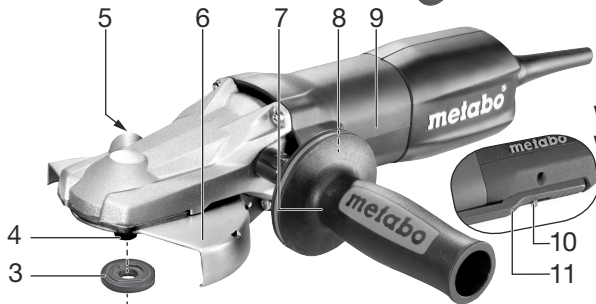

**WEF 9-125 Quick**  
**WEPF 9-125 Quick**



		<b>WF 18 LTX 125 Quick</b> *1) Serial Number: 01306..	<b>WEF 9-125 Quick</b> *1) Serial Number: 13060..	<b>WEPF 9-125 Quick</b> *1) Serial Number: 13069..
		<b>WPF 18 LTX 125 Quick</b> *1) Serial Number: 13070..		
<b>U</b>	<b>V</b>	18	-	-
<b>D<sub>max</sub></b>	mm (in)	125 (5)		
<b>t<sub>max1</sub>; t<sub>max2</sub>; t<sub>max3</sub></b>	mm (in)	8; 6; 6 ( <sup>5</sup> / <sub>16</sub> ; <sup>1</sup> / <sub>4</sub> ; <sup>1</sup> / <sub>4</sub> )		
 <b>M / I</b>	- / mm (in)	M 14 / 18 ( <sup>23</sup> / <sub>32</sub> )		
<b>n</b>	min <sup>-1</sup> (rpm)	8000	10000	10500
<b>P<sub>1</sub></b>	W	-	910	910
<b>P<sub>2</sub></b>	W	-	430	430
<b>m</b>	kg (lbs)	2,4 (5.3)	2,1 (4.6)	2,1 (4.6)
<b>a<sub>h,SG</sub>/K<sub>h,SG</sub></b>	m/s <sup>2</sup>	4,5 / 1,5	5,5 / 1,5	5,5 / 1,5
<b>a<sub>h,DS</sub>/K<sub>h,DS</sub></b>	m/s <sup>2</sup>	2,5 / 1,5	< 2,5	< 2,5
<b>L<sub>pA</sub>/K<sub>pA</sub></b>	dB(A)	83 / 3	88 / 3	88 / 3
<b>L<sub>WA</sub>/K<sub>WA</sub></b>	dB(A)	94 / 3	99 / 3	99 / 3



\*2) 2014/30/EU, 2006/42/EC, 2011/65/EU

\*3) EN 60745-1:2009+A11:2010, EN 60745-2-3:2011+A2:2013+A11:2014+A12:2014+A13:2015, EN IEC 63000:2018

ppa. B.F.

2021-05-04, Bernd Fleischmann  
Direktor Produktentstehung & Qualität (Vice President Product Engineering & Quality)

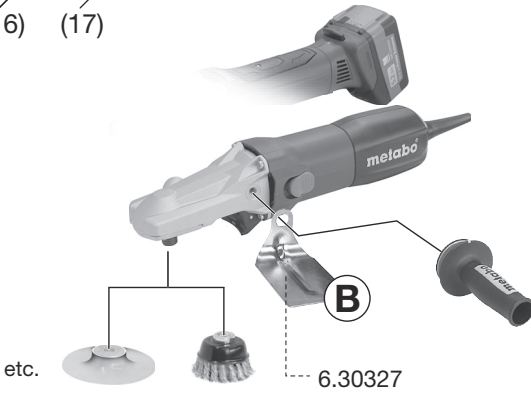
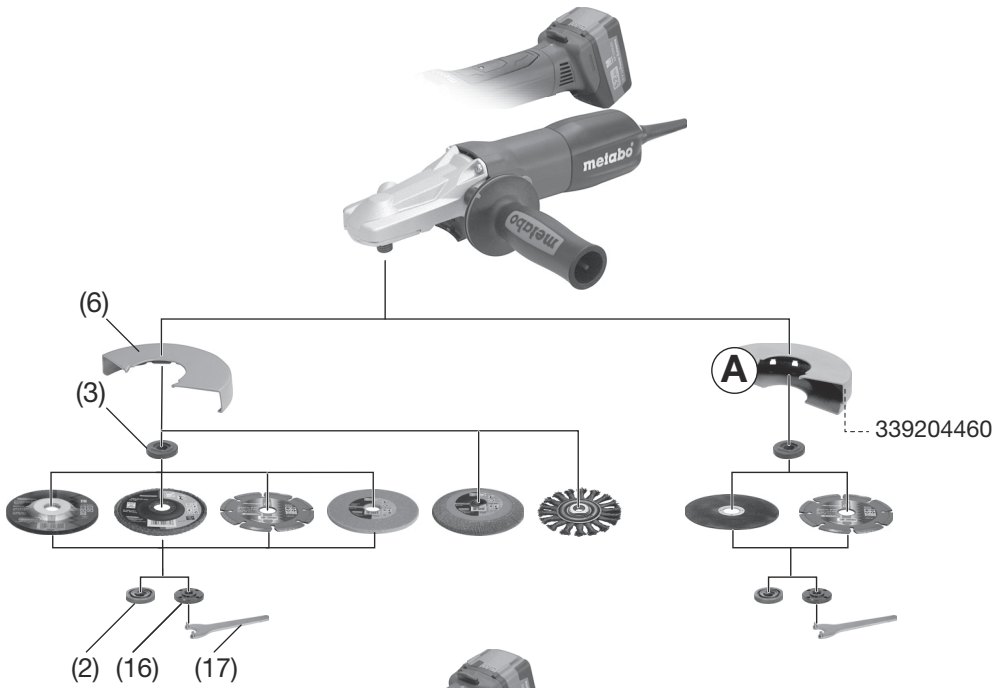

ASC Ultra

(C)



ASC 15



ASC 30-36



etc.

(D)



18 V 3,0 Ah 6.25594 Li-Power  
 18 V 4,0 Ah 6.25591 Li-Power  
 18 V 5,2 Ah 6.25592 Li-Power  
 etc.

# Original instructions

## 1. Declaration of Conformity

On our own responsibility, we hereby declare that these angle grinders, identified by type and serial number \*1), meet all relevant requirements of directives \*2) and standards \*3). Technical documents for \*4) - see Page 3.

### For UK only:

**UK** We as manufacturer and authorized person to **CA** compile the technical file, see \*4) on page 3, hereby declare under sole responsibility that these angle grinders, identified by type and serial number \*1) on page 3, fulfill all relevant provisions of following UK Regulations \*2) S.I. 2016/1091, S.I. 2008/1597, S.I. 2012/3032 and Designated Standards EN 60745-1:2009+A11:2010, EN 60745-2-3:2011+A2:2013+A11: 2014+A12: 2014+A13:2015, EN IEC 63000:2018.

## 2. Specified Use

The flat head angle grinders, when fitted with original Metabo accessories, are suitable for grinding, sanding, cutting-off and wire brushing metal, concrete, stone and similar materials without the use of water.

The user bears sole responsibility for any damage caused by improper use.

Generally accepted accident prevention regulations and the enclosed safety information must be observed.

## 3. General safety instructions



For your own protection and for the protection of your electrical tool, pay attention to all parts of the text that are marked with this symbol!



**WARNING** – Reading the operating instructions will reduce the risk of injury.



**WARNING** Read all safety warnings and instructions. Failure to follow all safety warnings and instructions may result in electric shock, fire and/or serious injury.

**Keep all safety instructions and information for future reference.**

Pass on your electrical tool only together with these documents.

## 4. Special Safety Instructions

### 4.1 Safety Warnings Common for Grinding, Sanding, Wire Brushing or Abrasive Cutting-Off Operations:

#### Use

a) This power tool is intended to function as a grinder, sander, wire brush or cut-off tool. Read all safety warnings, instructions, illustrations

and specifications provided with this power tool. Failure to follow all the instructions may result in electric shock, fire and/or serious injury.

b) **Operations such as polishing are not recommended to be performed with this power tool.**

Operations for which the power tool was not designed may create a hazard and cause personal injury.

c) **Do not use accessories which are not specifically designed and recommended by the tool manufacturer.** Just because the accessory can be attached to your power tool, it does not assure safe operation.

d) **The rated speed of the accessory must be at least equal to the maximum speed marked on the power tool.** Accessories running faster than their rated speed can break and fly apart.

e) **The outside diameter and the thickness of your accessory must be within the capacity rating of your power tool.** Incorrectly sized accessories cannot be adequately guarded or controlled.

f) **Threaded mounting of accessories must match the grinder spindle thread. For accessories mounted by flanges, the arbour hole of the accessory must fit the locating diameter of the flange.** Accessories that do not match the mounting hardware of the power tool will run out of balance, vibrate excessively and may cause loss of control.

g) **Do not use a damaged accessory. Before each use, inspect accessories such as abrasive wheels for chips and cracks, backing pad for cracks, tear or excess wear, wire brush for loose or cracked wires. If a power tool or accessory is dropped, check it for damage or install an undamaged accessory. After inspecting and installing an accessory, position yourself and bystanders away from the plane of the rotating accessory and run the power tool at maximum no-load speed for one minute.** Damaged accessories will normally break apart during this test time.

h) **Wear personal protective equipment. Depending on application, use a face shield, safety goggles or safety glasses. As appropriate, wear dust mask, hearing protectors, gloves and workshop apron capable of stopping small abrasive or workpiece fragments.** The eye protection must be capable of stopping flying debris generated by various operations. The dust mask or respirator must be capable of filtering particles generated by your operation. Prolonged exposure to high intensity noise may cause hearing loss.

i) **Keep bystanders a safe distance away from work area. Anyone entering the work area must wear personal protective equipment.** Fragments of workpiece or of a broken accessory may fly away and cause injury beyond immediate area of operation.

j) **Hold power tool by insulated gripping surfaces only, when performing an operation**

where the cutting accessory may contact hidden wiring or its own cord. Cutting accessory contacting a "live" wire may make exposed metal parts of the power tool "live" and shock the operator.

k) **Position the cord clear of the spinning accessory.** If you lose control, the cord may be cut or snagged and your hand or arm may be pulled into the spinning accessory.

l) **Never lay the power tool down until the accessory has come to a complete stop.** The spinning accessory may grip the surface and pull the power tool out of your control.

m) **Do not run the power tool while carrying it at your side.** Accidental contact with the spinning accessory could snag your clothing, pulling the accessory into your body.

n) **Regularly clean the power tool's air vents.** The motor's fan will draw the dust inside the housing and excessive accumulation of powdered metal may cause electrical hazards.

o) **Do not operate the power tool near flammable materials.** Sparks could ignite these materials.

p) **Do not use accessories that require liquid coolants.** Using water or other liquid coolants may result in electrocution or shock.

#### 4.2 Kickback and Related Warnings

Kickback is a sudden reaction to a pinched or snagged rotating wheel, backing pad, brush or any other accessory. Pinching or snagging causes rapid stalling of the rotating accessory which in turn causes the uncontrolled power tool to be forced in the direction opposite to the accessory's rotation at the point of jamming.

For example, if an abrasive wheel is snagged or pinched by the workpiece, the edge of the wheel that is entering into the pinch point can dig into the surface of the material causing the wheel to climb out or kick out. The wheel may either jump toward or away from the operator, depending on direction of the wheel's movement at the point of pinching. Abrasive wheels may also break under these conditions.

Kickback is the result of power tool misuse and/or incorrect operating procedures or conditions and can be avoided by taking proper precautions as given below.

a) **Maintain a firm grip on the power tool and position your body and arm to allow you to resist kickback forces. Always use the auxiliary handle, if provided, for maximum control over kickback or torque reaction during start-up.** The operator can control torque reactions or kickback forces, if proper precautions are taken.

b) **Never place your hand near the rotating accessory.** Accessory may kickback over your hand.

c) **Do not position your body in the area where power tool will move if kickback occurs.** Kickback will propel the tool in direction opposite to the wheel's movement at the point of snagging

d) **Use special care when working around corners, sharp edges etc. Avoid bouncing and snagging the accessory.** Corners, sharp edges or bouncing have a tendency to snag the rotating accessory and cause loss of control or kickback.

e) **Do not attach a saw chain woodcarving blade or toothed saw blade.** Such blades create frequent kickback and loss of control.

#### 4.3 Safety Warnings Specific for Grinding and Cutting-Off Operations:

a) **Use only wheel types that are recommended for your power tool and the specific guard designed for the selected wheel.** Wheels for which the power tool was not designed cannot be adequately guarded and are unsafe.

b) **The grinding surface of centre depressed wheels must be mounted below the plane of the guard lip.** An improperly mounted wheel that projects through the plane of the guard lip cannot be adequately protected.

c) **The guard must be securely attached to the power tool and positioned for maximum safety, so the least amount of wheel is exposed towards the operator.** The guard helps to protect the operator from broken fragments, accidental contact with the wheel and sparks which could ignite clothing.

d) **Wheels must be used only for recommended applications.**

**For example: do not grind with the side of the cut-off wheel.** Abrasive cut-off wheels are intended for peripheral grinding, side forces applied to these wheels may cause them to shatter.

e) **Always use undamaged wheel flanges that are of correct size and shape for your selected wheel.** Proper wheel flanges support the wheel thus reducing the possibility of wheel breakage. Flanges for cut-off wheels may be different from grinding wheel flanges.

f) **Do not use worn down wheels from larger power tools.** Wheels intended for larger power tools are not suitable for the higher speed of a smaller tool and may burst.

#### 4.4 Additional Safety Warnings Specific for Abrasive Cutting-Off Operations:

a) **Do not "jam" the cut-off wheel or apply excessive pressure. Do not attempt to make excessively deep cuts.** Overstressing the wheel increases the loading and susceptibility to twisting or binding of the wheel in the cut and the possibility of kickback or wheel breakage.

b) **Do not position your body in line with and behind the rotating wheel.** When the wheel, at the point of operation, is moving away from your body, the possible kickback may propel the spinning wheel and the power tool directly at you.

c) **If the wheel jams or if you interrupt a cut for any reason, switch off the power tool and hold the power tool motionless until the wheel comes to a complete stop. Never attempt to remove the cut-off wheel from the cut while the wheel is in motion, otherwise kickback may**

**occur.** Investigate and take corrective action to eliminate the cause of the wheel jam.

**d) Do not restart the cutting operation in the workpiece. Let the wheel reach full speed and carefully reenter the cut.** The wheel may jam, walk up or kickback if the power tool is restarted in the workpiece.

**e) Support panels or any oversized workpiece to minimise the risk of wheel pinching and kick-back.** Large workpieces tend to sag under their own weight. Supports must be placed under the workpiece near the line of cut and near the edge of the workpiece on both sides of the wheel.

**f) Use extra caution when making a "pocket cut" into existing walls or other blind areas.** The protruding wheel may cut gas or water pipes, electrical wiring or objects that can cause kickback.

#### 4.5 Safety Warnings Specific for Sanding Operations:

**a) Do not use oversized sanding disc paper. Follow manufacturer's recommendations when selecting sanding paper.** Larger sanding paper extending beyond the sanding pad presents a laceration hazard and may cause snagging, tearing of the disc or kickback.

#### 4.6 Safety Warnings Specific for Wire Brushing Operations:

**a) Be aware that wire bristles are lost by the brush even during ordinary operation. Do not overstress the wires by applying excessive load to the brush.** The wire bristles can easily penetrate light clothing and/or skin.

**b) If the use of a safety guard is recommended for wire brushing, do not allow any interference of the wire wheel or brush with the guard.** Wire wheel or brush may expand in diameter due to work load and centrifugal forces.

#### 4.7 Additional Safety Instructions



**WARNING** – Always wear protective goggles.

Use elastic cushioning layers if they have been supplied with the abrasive and if required.

Observe the specifications of the tool or accessory manufacturer! Protect the discs from grease or impacts!

Grinding discs must be stored and handled with care in accordance with the manufacturer's instructions.

Never use parting grinder discs for roughing work. Do not apply pressure to the side of parting grinder discs.

The workpiece must lay flat and be secured against slipping, e.g. using clamps. Large workpieces must be supported adequately.

If accessories with threaded inserts are used, the end of the spindle may not touch the base of the hole on the grinding tool. Make sure that the thread in the accessory is long enough to accommodate the full length of the spindle. The thread in the

accessory must match the thread on the spindle. See page 3 and chapter 14. Technical Specifications for more information on the spindle length and thread.

Damaged, eccentric or vibrating tools must not be used.

Avoid damage to gas or water pipes, electrical cables and load-bearing walls (static).

Connect a FI circuit-breaker with max. release current (30 mA) upstream when using the machine outdoors!

A damaged or cracked additional handle must be replaced. Never operate a machine with a defective additional handle.

Do not use safety guards that are damaged. Before use, check the safety guards for cracks, deformations or signs of severe wear and tear.

This power tool is not suitable for polishing work. Improper use of the machine will void the warranty! The motor may overheat and damage the electric power tool. We recommend using our angle polisher for polishing work.

#### 4.8 Special safety instructions for mains powered machines:

Pull the plug out of the plug socket before any adjustments, conversions or servicing are performed.



During machining, of metals in particular, conductive dust can form deposits inside the machine. This can lead to the transfer of electrical energy onto the machine housing. This can mean a temporary danger of electric shocks. This is why it is necessary when the machine is running to blow compressed air through the rear ventilation slots of the machine regularly, frequently and thoroughly. Here, the machine must be held firmly.

We recommend using a stationary extractor system and connecting a residual current circuit-breaker (FI) upstream. When the machine is shut down via the FI circuit-breaker, it must be checked and cleaned. See chapter 9. Cleaning for more information on cleaning the motor.

#### 4.9 Special safety instructions for cordless machines:

Remove the battery pack from the machine before any adjustments, conversions or servicing are performed.



Protect battery packs from water and moisture!



Do not expose battery packs to naked flame!

Do not use faulty or deformed battery packs!

Do not open battery packs!

Do not touch or short-circuit battery packs!



Slightly acidic, flammable fluid may leak from defective li-ion battery packs!



If battery fluid leaks out and comes into contact with your skin, rinse immediately with plenty of water. If battery fluid leaks out and comes into contact with your eyes, wash them with clean water and seek medical attention immediately.

If the machine is defective, remove the battery pack from the machine.

### Transport of li-ion battery packs:

The shipping of li-ion battery pack is subject to laws related to the carriage of hazardous goods (UN 3480 and UN 3481). Inform yourself of the currently valid specifications when shipping li-ion battery packs. If necessary, consult your freight forwarder. Certified packaging is available from Metabo.

Only send the battery pack if the housing is intact and no fluid is leaking. Remove the battery pack from the machine for sending. Prevent the contacts from short-circuiting (e.g. by protecting them with adhesive tape).

### Reducing dust exposure:

**⚠ WARNING** - Some dust created by power sanding, sawing, grinding, drilling, and other construction activities contains chemicals known to cause cancer, birth defects or other reproductive harm. Some examples of these chemicals are:

- Lead from lead-based paints,
- Crystalline silica from bricks and cement and other masonry products, and
- Arsenic and chromium from chemically treated lumber.

Your risk from these exposures varies, depending on how often you do this type of work. To reduce your exposure to these chemicals: work in a well ventilated area, and work with approved safety equipment, such as those dust masks that are specially designed to filter out microscopic particles.

This also applies to dust from other materials such as some timber types (like oak or beech dust), metals, asbestos. Other known diseases are e.g. allergic reactions, respiratory diseases. Do not let dust enter the body.

Observe the relevant guidelines and national regulations for your material, staff, application and place of application (e.g. occupational health and safety regulations, disposal).

Collect the particles generated at the source, avoid deposits in the surrounding area.

Use suitable accessories for special work. In this way, fewer particles enter the environment in an uncontrolled manner.

Use a suitable extraction unit.

Reduce dust exposure with the following measures:

- do not direct the escaping particles and the exhaust air stream at yourself or nearby persons or on dust deposits,
- use an extraction unit and/or air purifiers,
- ensure good ventilation of the workplace and keep clean using a vacuum cleaner. Sweeping or blowing stirs up dust.
- Vacuum or wash the protective clothing. Do not blow, beat or brush.

## 5. Overview

See page 2.

- 1 Clip to tighten/release the (tool-free) clamping nut manually \*
- 2 Clamping nut (tool-free) \*
- 3 Support flange
- 4 Spindle
- 5 Spindle locking button
- 6 Safety guard
- 7 Additional handle / Additional handle with vibration damping \*
- 8 Sliding on/off switch \*
- 9 Handle
- 10 Switch-on lock \*
- 11 Trigger \*
- 12 Electronic signal indicator \*
- 13 Battery pack release button \*
- 14 Capacity indicator button \*
- 15 Capacity and signal indicator \*
- 16 Battery pack\*
- 17 Dust filter \*
- 18 Clamping nut \*
- 19 2-hole spanner \*
- 20 Lever for safety guard attachment

\* depending on equipment/not in scope of delivery

## 6. Initial Operation

### 6.1 For mains powered machines only

**⚠** Before plugging in the device, check that the rated mains voltage and mains frequency, as specified on the rating label, match your power supply.

**⚠** Always install an RCD with a max. trip current of 30 mA upstream.

### 6.2 For cordless machines only

#### Dust filter

**⚠** Always fit the dust filter if the surroundings are heavily polluted (17).

**⚠** The machine heats up faster when the dust filter is fitted (17). It is protected by the electronics system from overheating (see chapter10.).

Attaching: See page 2, illustration A. Attach dust filter (17) as shown.

To remove: Holding the dust filter (17) by the upper edges, raise it slightly and then pull it downwards and remove.

#### Rotating battery pack

See illustration B on page 2.

The rear section of the machine can be rotated 270° in three stages, thus allowing the machine's shape to be adapted to the working conditions. Only operate the machine when it is in an engaged position.

#### Battery pack

Charge the battery pack before use (16).



If performance diminishes, recharge the battery pack.

The ideal storage temperature is between 10°C and 30°C.

"Li-Power" li-ion battery packs have a capacity and signal indicator: (15)

- Press the button (14), the LEDs indicate the charge level.
- If one LED is flashing, the battery pack is almost flat and must be recharged.

### Removing and inserting the battery pack

To remove: Press the battery pack release button (13) and pull the battery pack (16) downwards.

To fit: Slide in the battery pack (16) until it engages.

### 6.3 Attaching the additional handle

 Always work with the additional handle attached (7)! Attach the additional handle on the left or right of the machine and secure.

### 6.4 Install safety guard

 For safety reasons, always use the safety guard provided for the respective wheel! See also chapter 11.

#### Safety guard for grinding

Designed for work with roughing wheels, flap sanding pads, diamond cut-off wheels.

See page 2, illustration E.

- Place the safety guard (6) in the position indicated.
- Push the lever and turn the safety guard until the closed section is facing the operator.
- Release the lever and turn the safety guard until the lever engages.
- Make sure that the guard is seated securely: the lever must engage and you should not be able to turn the safety guard.

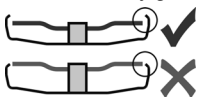

Use only accessories that are covered by at least 3.4 mm by the safety guard.

## 7. Attaching the grinding wheel

 Before carrying out any modifications, remove the battery pack from the machine and pull the mains plug from the socket. The machine must be switched off and the spindle must be at a standstill.

 For reasons of safety, attach the parting guard before performing parting work (see chapter 11. Accessories).

### 7.1 Locking the spindle

 Press in the spindle locking button (5) only when the spindle is stationary!

- Press in the spindle locking button (5) and turn the spindle (4) by hand until you feel the spindle locking button engage.

### 7.2 Placing the grinding wheel in position

See illustration C on page 2.

- Fit the support flange (3) on the spindle. The flange should not turn on the spindle when properly attached.
- Place the grinding wheel on the support flange (3). The grinding wheel must lay flat on the supporting flange. The metal flange on the parting grinder disc must lay flat on the support flange.

### 7.3 Securing/releasing the (tool-free) clamping nut (depending on features)

 Only tighten the (tool-free) clamping nut (2) manually.

 For the machine to operate, the clip (1) must always lie flat on clamping nut (2) .

#### To secure the (tool-free) clamping nut (2):

 Do not use the (tool-free) clamping nut if the accessory has a clamping shank thicker than 6 mm! In this case, use the clamping nut (18) with 2-hole spanner (19).

- Lock the spindle (see chapter 7.1).
- Flip up the clip (1) on the clamping nut.
- Fit the clamping nut (2) on the spindle (4). See illustration D on page 2.
- (1) Tighten the clamping nut **on the clip manually** in a clockwise direction.
- Flip down the clip (1) again .

#### To release the (tool-free) clamping nut (2) :

- Lock the spindle (see chapter 7.1).
- Flip up the clip (1) on the clamping nut.
- Unscrew the clamping nut (2) , turning it anticlockwise **manually** .

**Note:** If the clamping nut is very tightly secured (2), you can also use a 2-hole spanner to unscrew it.

### 7.4 Tightening/loosening the clamping nut

#### Securing the clamping nut (18):

The 2 sides of the clamping nut are different. Screw the clamping nut onto the spindle as follows:

See illustration D on page 2.

#### - A) For thin grinding wheels:

The edge of the clamping nut (18) faces upwards so that the thin grinding wheel can be attached securely.

#### B) For thick grinding wheels:

The edge of the clamping nut (18) faces downwards so that the clamping nut can be attached securely to the spindle.

- Lock the spindle. Turn the clamping nut (18) clockwise using the 2-hole spanner (19) to secure.

#### Releasing the clamping nut:

- Lock the spindle (see chapter 7.1). Turn the clamping nut (18) anticlockwise using the 2-hole spanner (19) to unscrew.

## 8. Use

### 8.1 Switching On and Off

 Always guide the machine with both hands.

 Switch on first, then guide the accessory towards the workpiece.

 The machine must not be allowed to draw in additional dust and shavings. When switching the machine on and off, keep it away from dust deposits. After switching off the machine, only place it down when the motor has come to a standstill.

 Avoid switching on the machine accidentally: always switch it off when the battery pack is removed from the machine.

 Avoid inadvertent starts: always switch the tool off when the plug is removed from the mains socket or if there has been a power cut.

 In continuous operation, the machine continues running if it is forced out of your hands. Therefore, always hold the machine with both hands using the handles provided, stand in a safe position and concentrate.

**Machines with slide switch:**

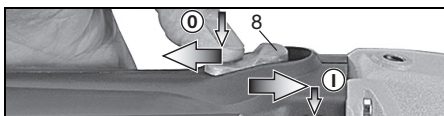

**Switching on:** Push the slide switch (8) forward. For continuous activation, now tilt downwards until it engages.

**Switching off:** Press the rear end of the slide switch (8) and release.

**Machines with Paddle Switch (with dead man function):**

(machines with the designation WPF..., WEPF...)

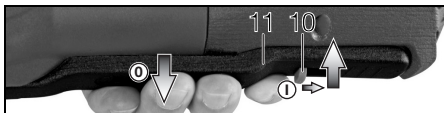

**Switching on:** Slide the switch-on lock (10) in the direction of the arrow and press the trigger (11).

**Switching off:** Release the trigger (11).

**8.2 Working instructions**

**Grinding and sanding operations:**

Press down the machine evenly on the surface and move back and forth so that the surface of the workpiece does not become too hot.

**Roughing:** position the machine at an angle of 30° - 40° for the best working results.

**Cutting-off:**

 Always work against the run of the disc (see illustration). Otherwise there is the danger of the machine kicking back from the cut out of control. Guide the machine evenly at a speed suitable for the material being processed. Do not tilt, apply excessive force or sway from side to side.

**Wire brushing:**

Press down the machine evenly.

**9. Cleaning**

**Motor cleaning:** blow compressed air through the rear ventilation slots of the machine regularly, frequently and thoroughly. Here, the machine must be held firmly.

Clean the **dust filter** regularly: remove and clean with a jet of compressed air.

**10. Troubleshooting**

**10.1 Mains powered machines:**

- **Overload protection: There is a MAJOR reduction in load speed.** The motor temperature is too high! Allow the machine to run at idle speed until it has cooled down.
- **Overload protection: There is a SLIGHT reduction in load speed.** The machine is overloaded. Reduce the load before continuing to work.
- **Metabo S-automatic safety shutdown: The machine was SWITCHED OFF automatically.** If the slew rate of the current is too high (for example, if the machine suddenly seizes or kick-back occurs), the machine switches off. Switch off the machine at the slide switch (8). Switch it on again and continue to work as normal. Try to prevent the machine from seizing. See section 4.2.
- **Restart protection: The machine does not start.** The restart protection is active. If the mains plug is inserted with the machine switched on, or if the current supply is restored following an interruption, the machine does not start up. Switch the machine off and on again.

**10.2 Cordless machines:**

- **The electronic signal display (12) lights up and the load speed decreases.** The temperature is too high! Run the machine in idling until the electronics signal indicator switches off.
- **The electronic signal display (12) flashes and the machine does not start.** The restart protection is active. The machine will not start if the battery pack is inserted while the machine is on. Switch the machine off and on again.

**11. Accessories**

Only use original Metabo battery packs and Metabo accessories.

See page 4.

Use only accessories that fulfil the requirements and specifications listed in these operating instructions.

**A Safety guard for cut-off grinding**

Designed for work with cut-off wheels, diamond cut-off wheels.

Install as described under "Safety guard for grinding" (chapter 6.4).

**B Hand guard for sanding and wire brushing operations**

Designed for work with support plates, sanding pads, wire brushes.

Install hand guard under the additional side-mounted handle.

**C Chargers**

**D Battery packs**

For a complete range of accessories, see [www.metabo.com](http://www.metabo.com) or the accessories catalogue.

**12. Repairs**

 Repairs to electrical tools must be carried out by qualified electricians ONLY!

If you have Metabo electrical tools that require repairs, please contact your Metabo service centre. For addresses see [www.metabo.com](http://www.metabo.com).

You can download spare parts lists from [www.metabo.com](http://www.metabo.com).

**13. Environmental Protection**

The sanding dust generated may contain hazardous materials: do not dispose of with the household waste, but at a special collection point for hazardous waste.

Observe national regulations on environmentally compatible disposal and on the recycling of disused machines, packaging and accessories.

 Only for EU countries: Never dispose of power tools in your household waste! In accordance with European Guideline 2012/19/EU on used electronic and electric equipment and its implementation in national legal systems, used power tools must be collected separately and returned for environmentally compatible recycling.

**Special instructions for cordless machines:**

Battery packs must not be disposed of with regular waste. Return faulty or used battery packs to your Metabo dealer!

Do not allow battery packs to come into contact with water!

Before disposal, discharge the battery pack in the power tool. Prevent the contacts from short-circuiting (e. g. by protecting them with adhesive tape).

**14. Technical specifications**

Explanation of details on page 3. Subject to changes serving technical progress.

- U = Voltage of battery pack
- D<sub>max</sub> = max. diameter of accessory
- t<sub>max,1</sub> = Max. permitted thickness of clamping shank on accessory when using clamping nut (18)
- t<sub>max,2</sub> = max. permitted thickness of clamping shank on accessory when using "Quick"clamping nut (2)
- t<sub>max,3</sub> = Roughing wheel/cut-off wheel: max. permissible thickness of the accessory tool
- M = Spindle thread
- l = Length of the grinding spindle

- n\* = No-load speed (maximum speed)
- P<sub>1</sub> = Nominal power input
- P<sub>2</sub> = Power output
- m = Weight with smallest battery pack/ weight without cord

Measured values determined in conformity with EN 60745.

-  Machine in protection class II
- ~ Alternating current
- == Direct current

The technical specifications quoted are subject to tolerances (in compliance with the relevant valid standards).

**Electromagnetic disturbances:**

In individual cases, the speed may fluctuate temporarily if the machine is exposed to extreme external electromagnetic disturbances or the electronic restart protection may respond. In this case, switch the machine off and on again.

 **Emission values**

Using these values, you can estimate the emissions from this power tool and compare these with the values emitted by other power tools. The actual values may be higher or lower, depending on the particular application and the condition of the tool or power tool. In estimating the values, you should also include work breaks and periods of low use. Based on the estimated emission values, specify protective measures for the user - for example, any organisational steps that must be put in place.

Vibration total value (vector sum of three directions) determined in accordance with EN 60745:

a<sub>h,SG</sub> = Vibration emission value (surface grinding)

a<sub>h,DS</sub> = Vibration emission value (disc sanding)

K<sub>h,SG/DS</sub> = Uncertainty (vibration)

Typical A-effective perceived sound levels::

L<sub>pA</sub> = Sound pressure level

L<sub>WA</sub> = Acoustic power level

K<sub>pA</sub>, K<sub>WA</sub> = Uncertainty

During operation the noise level can exceed 80 dB(A).

 **Wear ear protectors!**