

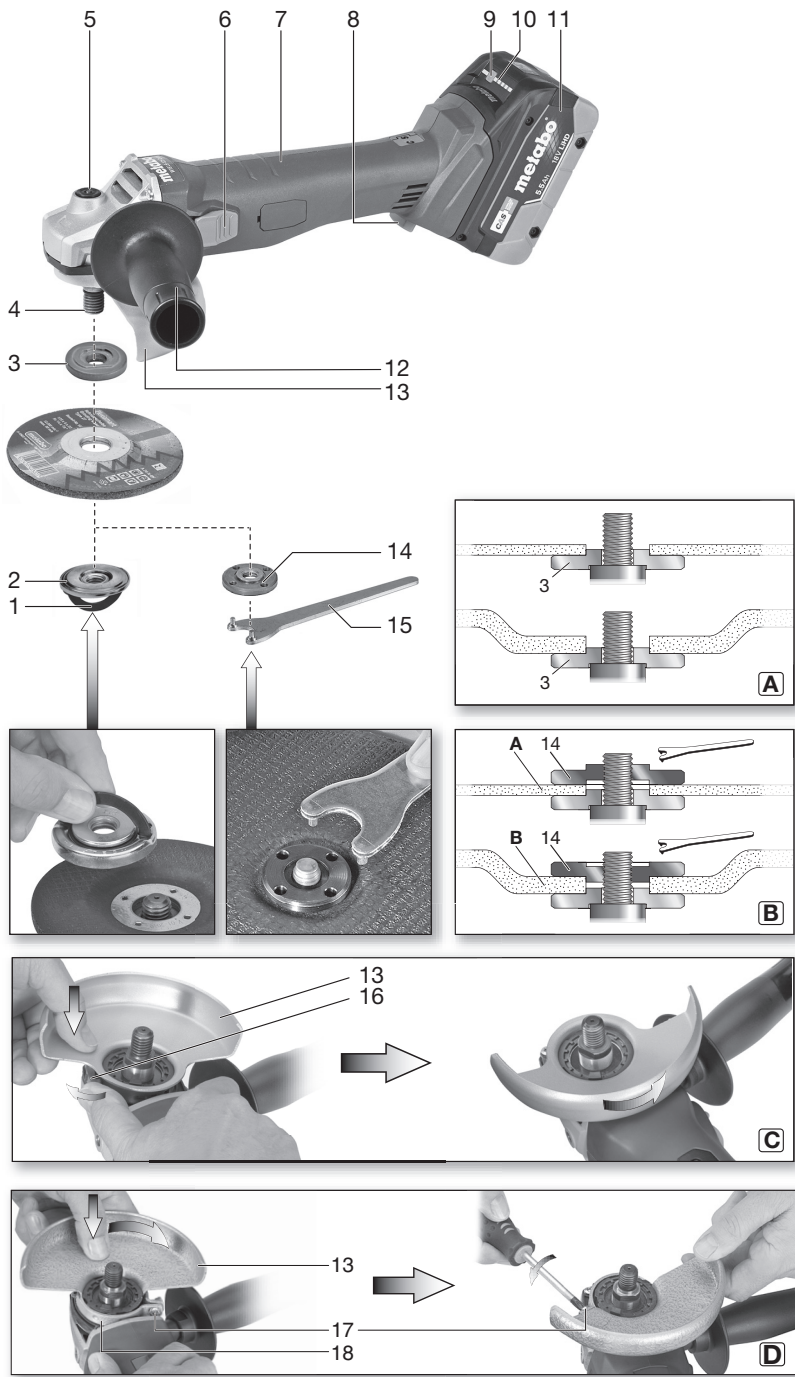

W 18 L 9-115  
W 18 L 9-125  
W 18 L 9-125 Quick



---

<b>de</b>	Originalbetriebsanleitung	5	<b>fi</b>	Alkuperäiset ohjeet	69
<b>en</b>	Original instructions	13	<b>no</b>	Original bruksanvisning	77
<b>fr</b>	Notice originale	21	<b>da</b>	Original brugsanvisning	84
<b>nl</b>	Oorspronkelijke gebruiksaanwijzing	29	<b>pl</b>	Instrukcja oryginalna	92
<b>it</b>	Istruzioni originali	37	<b>el</b>	Πρωτότυπες οδηγίες λειτουργίας	100
<b>es</b>	Manual original	45	<b>hu</b>	Eredeti használati utasítás	109
<b>pt</b>	Manual original	54	<b>ru</b>	Оригинальное руководство по эксплуатации	117
<b>sv</b>	Originalbruksanvisning	62			



		<b>W 18 L 9-115</b> <small>(1) Serial Number 02246...</small>	<b>W 18 L 9-125</b> <small>(1) Serial Number 02247...</small>	<b>W 18 L 9-125 Quick</b> <small>(1) Serial Number 02249...</small>
<b>D<sub>max</sub></b>	mm (in)	115 (4 1/2)	125 (5)	125 (5)
<b>U</b>	V	18		
<b>t<sub>max1</sub>; t<sub>max2</sub>; t<sub>max3</sub>; t<sub>max4</sub></b>	mm (in)	10; 6; 8; 15 (3/8; 1/4; 5/16; 19/32)		
 <b>M / I</b>	- / mm (in)	M 14 / 19 (3/4)		
<b>n</b>	min <sup>-1</sup> (rpm)	8500		
<b>m</b>	kg (lbs)	2,3 (5.1)		
<b>a<sub>h,SG</sub>/K<sub>h,SG</sub></b>	m/s <sup>2</sup>	4,5/1,5	5,0/1,5	
<b>a<sub>h,DS</sub>/K<sub>h,DS</sub></b>	m/s <sup>2</sup>	< 2,5/1,5		
<b>L<sub>pA</sub>/K<sub>pA</sub></b>	dB(A)	85/3	86/3	
<b>L<sub>WA</sub>/K<sub>WA</sub></b>	dB(A)	96/3	96/3	



\*2) 2011/65/EU, 2006/42/EC, 2014/30/EU

\*3) EN 60745-1:2009+A11:2010,

EN 60745-2-3:2011+A2:2013+A11:2014+A12:2014+A13:2015, EN IEC 63000:2018

ppa. 

2021-11-24, Bernd Fleischmann





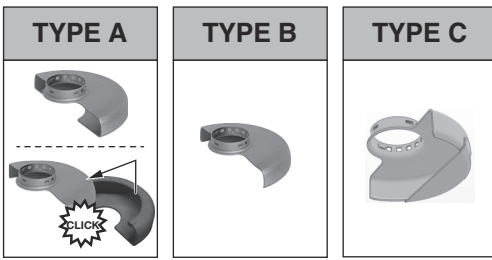





Direktor Produktentstehung & Qualität (Vice President Product Engineering & Quality)





\*4) Metabowerke GmbH - Metabo-Allee 1 - 72622 Nuertingen, Germany



\*1

\*1  $\varnothing_{\max} = 115 \text{ mm (4 } \frac{1}{2} \text{")}$  630351000  
 $\varnothing_{\max} = 125 \text{ mm (5")}$  630352000

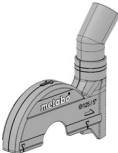
		TYPE
1	1.1 	B / C
2	2.1 	A / C
	2.2 	A
	2.3 	A
	2.4 	A / C
3	3.1 	-
4	4.1 	A / B / C
	4.2 	-
5	5.1 	B / C
	5.2 	-

- A**  ASC 145  
ASC 55  
etc.
- B**  4,0 Ah 625027000  
5,2 Ah 625028000  
5,5 Ah 625368000 (Li-HD)  
8,0 Ah 625369000 (Li-HD)  
10,0 Ah 625549000 (Li-HD)  
etc.
- C**   $\varnothing_{\max} = 125 \text{ mm (5")}$   
630401000
- D**  (M 14) 630706000
- E**  (M 14) 316062580

# Original instructions

## 1. Declaration of Conformity

We declare in our sole responsibility: These angle grinders, identified by type and serial number \*1), comply with all relevant requirements of the directives \*2) and standards \*3). Technical file at \*4) - see page 3.

### For UK only:

**UK** We as manufacturer and authorized person to  
**CA** compile the technical file, see \*4) on page 3, hereby declare under sole responsibility that these angle grinders, identified by type and serial number \*1) on page 3, fulfill all relevant provisions of following UK Regulations S.I. 2016/1091, S.I. 2008/1597, S.I. 2012/3032 and Designated Standards EN 60745-1:2009+A11:2010, EN 60745-2-3:2011+A2:2013+A11:2014+A12:2014+A13:2015, EN IEC 63000:2018.

## 2. Specified Use

The cordless angle grinders, when fitted with original Metabo accessories, are suitable for grinding, sanding, cutting-off and wire brushing metal, concrete, stone and similar materials without the use of water.

The user bears sole responsibility for any damage caused by improper use.

Generally accepted accident prevention regulations and the enclosed safety information must be observed.

## 3. General Safety Instructions



For your own protection and for the protection of your power tool, pay attention to all parts of the text that are marked with this symbol!



**WARNING** – Read the operating instructions to reduce the risk of injury.



**WARNING** – Read all safety warnings, instructions, illustrations and specifications provided with this power tool. Failure to follow all instructions listed below may result in electric shock, fire and/or serious injury.

**Keep all safety instructions and information for future reference.**

Always include these documents when passing on your power tool.

## 4. Special Safety Instructions

### 4.1 Safety Warnings Common for Grinding, Sanding, Wire Brushing or Cutting-Off Operations:

a) **This power tool is intended to function as a grinder, sander, wire brush, hole cutter or cut-**

**off tool. Read all safety warnings, instructions, illustrations and specifications provided with this power tool.** Failure to follow all instructions listed below may result in electric shock, fire and/or serious injury.

b) **Operations such as polishing are not to be performed with this power tool.** Operations for which the power tool was not designed may create a hazard and cause personal injury.

c) **Do not use accessories which are not specifically designed and specified by the tool manufacturer.** Just because an accessory can be attached to your power tool, it does not assure safe operation.

d) **The rated speed of the accessory must be at least equal to the maximum speed marked on the power tool.** Accessories running faster than their rated speed can break and fly apart.

e) **The outside diameter and the thickness of your accessory must be within the capacity rating of your power tool.** Incorrectly sized accessories cannot be adequately guarded or controlled.

f) **Threaded mounting of accessories must match the grinder spindle thread. For accessories mounted by flanges, the arbour hole of the accessory must fit the locating diameter of the flange.** Accessories that do not match the mounting hardware of the power tool will run out of balance, vibrate excessively and may cause loss of control.

g) **Do not use a damaged accessory. Before each use inspect the accessory such as abrasive wheels for chips and cracks, backing pad for cracks, tear or excess wear, wire brush for loose or cracked wires. If the power tool or accessory is dropped, inspect for damage or install an undamaged accessory. After inspecting and installing an accessory, position yourself and bystanders away from the plane of the rotating accessory and run the power tool at maximum no-load speed for one minute.** Damaged accessories will normally break apart during this test time.

h) **Wear personal protective equipment. Depending on application, use face shield, safety goggles or safety glasses. As appropriate, wear dust mask, hearing protectors, gloves and workshop apron capable of stopping small abrasive or workpiece fragments.** The eye protection must be capable of stopping flying debris generated by various operations. The dust mask or respirator must be capable of filtering particles generated by your operation. Prolonged exposure to high-intensity noise may cause hearing loss.

i) **Keep bystanders a safe distance away from the work area. Anyone entering the work area must wear personal protective equipment.** Fragments of the workpiece or of a broken accessory may fly away and cause injury beyond immediate area of operation.

- j) **Hold the power tool by insulated gripping surfaces only, when performing an operation where the cutting accessory may contact hidden wiring or its own cord.** Cutting accessory contacting a "live" wire may make exposed metal parts of the power tool "live" and could give the operator an electric shock.
- k) **Position the cord clear of the spinning accessory.** If you lose control, the cord may be cut or snagged and your hand or arm may be pulled into the spinning accessory.
- l) **Never lay the power tool down until the accessory has come to a complete stop.** The spinning accessory may grab the surface and pull the power tool out of your control.
- m) **Do not run the power tool while carrying it at your side.** Accidental contact with the spinning accessory could snag your clothing, pulling the accessory into your body.
- n) **Regularly clean the power tool's air vents.** The motor's fan will draw the dust inside the housing and excessive accumulation of powdered metal may cause electrical hazards.
- o) **Do not operate the power tool near flammable materials.** Sparks could ignite these materials.
- p) **Do not use accessories that require liquid coolants.** Using water or other liquid coolants may result in electrocution or shock.

#### 4.2 Kickback and related warnings

Kickback is a sudden reaction to a pinched or snagged rotating wheel, backing pad, brush or any other accessory. Pinching or snagging causes rapid stalling of the rotating accessory, which in turn causes the uncontrolled power tool to be forced in the direction opposite of the accessory's rotation at the point of the binding.

For example, if an abrasive wheel is snagged or pinched by the workpiece, the edge of the wheel that is entering into the pinch point can dig into the surface of the material causing the wheel to climb out or kickback. The wheel may either jump toward or away from the operator, depending on direction of the wheel's movement at the point of pinching. Abrasive wheels may also break under these conditions.

Kickback is the result of power tool misuse and/or incorrect operating procedures or conditions and can be avoided by taking proper precautions as given below.

- a) **Maintain a firm grip with both hands on the power tool and position your body and arms to allow you to resist kickback forces. Always use the auxiliary handle, if provided, for maximum control over kickback or torque reaction during start-up.** The operator can control torque reactions or kickback forces, if proper precautions are taken.
- b) **Never place your hand near the rotating accessory.** Accessory may kickback over your hand.
- c) **Do not position your body in the area where the power tool will move if kickback occurs.**

Kickback will propel the tool in direction opposite to the wheel's movement at the point of snagging.

- d) **Use special care when working corners, sharp edges etc. Avoid bouncing and snagging the accessory.** Corners, sharp edges or bouncing have a tendency to snag the rotating accessory and cause loss of control or kickback.
- e) **Do not attach a saw chain woodcarving blade, segmented diamond wheel with a peripheral gap greater than 10 mm or toothed saw blade.** Such blades create frequent kickback and loss of control.

#### 4.3 Safety warnings specific for grinding and cutting-off operations:

- a) **Use only wheel types that are specified for your power tool and the specific guard designed for the selected wheel.** Wheels for which the power tool was not designed cannot be adequately guarded and are unsafe.
- b) **The grinding surface of centre depressed wheels must be mounted below the plane of the guard lip.** An improperly mounted wheel that projects through the plane of the guard lip cannot be adequately protected.
- c) **The guard must be securely attached to the power tool and positioned for maximum safety, so the least amount of wheel is exposed towards the operator.** The guard helps to protect the operator from broken wheel fragments, accidental contact with wheel and sparks that could ignite clothing.
- d) **Wheels must be used only for specified applications. For example: do not grind with the side of cut-off wheel.** Abrasive cut-off wheels are intended for peripheral grinding, side forces applied to these wheels may cause them to shatter.
- e) **Always use undamaged wheel flanges that are of correct size and shape for your selected wheel.** Proper wheel flanges support the wheel thus reducing the possibility of wheel breakage. Flanges for cut-off wheels may be different from grinding wheel flanges.
- f) **Do not use worn down wheels from larger power tools.** Wheels intended for larger power tools are not suitable for the higher speed of a smaller tool and may burst.
- g) **When using dual purpose wheels always use the correct guard for the application being performed.** Failure to use the correct guard may not provide the desired level of guarding, which could lead to serious injury.

#### 4.4 Additional safety warnings specific for cutting-off operations:

- a) **Do not "jam" the cut-off wheel or apply excessive pressure. Do not attempt to make an excessively deep cut.** Overstressing the wheel increases the loading and susceptibility to twisting or binding of the wheel in the cut and the possibility of kickback or wheel breakage.
- b) **Do not position your body in line with and behind the rotating wheel.** When the wheel, at the

point of operation, is moving away from your body, the possible kickback may propel the spinning wheel and the power tool directly at you.

c) **When the wheel is binding or when interrupting a cut for any reason, switch off the power tool and hold it motionless until the wheel comes to a complete stop. Never attempt to remove the cut-off wheel from the cut while the wheel is in motion otherwise kickback may occur.** Investigate and take corrective action to eliminate the cause of wheel binding.

d) **Do not restart the cutting operation in the workpiece. Let the wheel reach full speed and carefully re-enter the cut.** The wheel may bind, walk up or kickback if the power tool is restarted in the workpiece.

e) **Support panels or any oversized workpiece to minimize the risk of wheel pinching and kickback. Large workpieces tend to sag under their own weight.** Supports must be placed under the workpiece near the line of cut and near the edge of the workpiece on both sides of the wheel.

f) **Use extra caution when making a “pocket cut” into existing walls or other blind areas.** The protruding wheel may cut gas or water pipes, electrical wiring or objects that can cause kickback.

g) **Do not attempt to do curved cutting.** Overstressing the wheel increases the loading and susceptibility to twisting or binding of the wheel in the cut and the possibility of kickback or wheel breakage, which can lead to serious injury.

#### 4.5 Safety warnings specific for sanding operations:

a) **Use proper sized sanding disc paper. Follow the manufacturer’s recommendations, when selecting sanding paper.** Larger sanding paper extending too far beyond the sanding pad presents a laceration hazard and may cause snagging, tearing of the disc or kickback.

#### 4.6 Safety warnings specific for wire brushing operations:

a) **Be aware that wire bristles are thrown by the brush even during ordinary operation. Do not overstress the wires by applying excessive load to the brush.** The wire bristles can easily penetrate light clothing and/or skin.

b) **If the use of a guard is specified for wire brushing, do not allow any interference of the wire wheel or brush with the guard.** Wire wheel or brush may expand in diameter due to work load and centrifugal forces.

#### 4.7 Additional Safety Instructions



**WARNING** – Always wear protective goggles.



Wear ear protectors.



**WARNING** – Always operate the power tool with two hands.



Do not use the guard for cutting-off operations. When working with cut-off wheels, always use the parting safety guard for safety reasons.

Do not use any segmented diamond cut-off wheels with segment slits >10 mm. Only negative segment cutting angles are permitted.

Use bonded cut-off wheels only if these are reinforced.

Use elastic cushioning layers if they have been supplied with the sanding media and if required.

Observe the specifications of the tool or accessory manufacturer! Protect wheels from grease or impact!

Accessories must be stored and handled with care in accordance with the manufacturer’s instructions.

Never use cut-off wheels for roughing work or deburring! Do not apply pressure to the side of the cut-off wheels.

The workpiece must lay flat and be secured against slipping, e.g. using clamps. Large workpieces must be sufficiently supported.

If accessories with threaded inserts are used, the end of the spindle may not touch the base of the hole on the grinding tool. Make sure that the thread in the accessory is long enough to accommodate the full length of the spindle. The thread in the accessory must match the thread on the spindle. See page 2 and chapter 14. Technical Specifications for more information on the spindle length and thread.

Damaged, eccentric or vibrating tools must not be used.

Avoid damage to gas or water pipes, electrical cables and load-bearing walls (static).

Remove the battery pack from the machine before any adjustments, conversions or servicing are performed.

Before fitting the battery pack, make sure that the machine is switched off.

Hold the machine when removing and inserting the battery back such that the on/off switch cannot be unintentionally pressed

If the machine is defective, remove the battery pack from the machine.

A damaged or cracked additional handle must be replaced. Never operate a machine with a defective additional handle.

A damaged or cracked safety guard must be replaced. Never operate a machine with a defective safety guard.

Secure small workpieces. For example, clamp in a vice.

When working in dusty conditions, ensure that ventilation openings are not blocked. If it becomes necessary to remove dust, first remove the battery

pack (use non-metallic objects) and avoid damaging internal components.

When using dual-purpose (combined grinding and cut-off wheels), only the following guard types must be used: type A, type C.  
See chapter 11.

### Using the correct guard:

Using an incorrect guard can lead to loss of control and serious injuries. Examples for incorrect use:

- when using a type A guard for lateral grinding, the guard may interfere with the workpiece causing poor control.
- when using a type B guard for cutting-off operations with bonded cut-off wheels, there is an increased risk of exposure to emitted sparks and particles, as well as exposure to wheel fragments in the event of a wheel burst.
- when using a type A, B, C guard for cutting-off operations or lateral grinding in concrete or masonry, there is an increased risk of exposure to dust and loss of control resulting in kickback.
- when using a type A, B, C guard with a wheel-type wire brush with a thickness greater than the maximum permitted thickness, the wires may catch on the guard leading to breaking of the wires.

Always use the matching guard for the accessory.  
See chapter 11.

### Reducing dust exposure:

 **WARNING** - Some dust created by power sanding, sawing, grinding, drilling, and other construction activities contains chemicals known to cause cancer, birth defects or other reproductive harm. Some examples of these chemicals are:

- Lead from lead-based paints,
- Crystalline silica from bricks and cement and other masonry products, and
- Arsenic and chromium from chemically treated lumber.

Your risk from these exposures varies, depending on how often you do this type of work. To reduce your exposure to these chemicals: work in a well ventilated area, and work with approved safety equipment, such as those dust masks that are specially designed to filter out microscopic particles.

This also applies to dust from other materials such as some timber types (like oak or beech dust), metals, asbestos. Other known diseases are e.g. allergic reactions, respiratory diseases. Do not let dust enter the body.

Observe the relevant guidelines and national regulations for your material, staff, application and place of application (e.g. occupational health and safety regulations, disposal).

Collect the particles generated at the source, avoid deposits in the surrounding area.

Use suitable accessories for special work. In this way, fewer particles enter the environment in an uncontrolled manner.

Use a suitable extraction unit.

Reduce dust exposure with the following measures:

- do not direct the escaping particles and the exhaust air stream at yourself or nearby persons or on dust deposits,
- use an extraction unit and/or air purifiers,
- ensure good ventilation of the workplace and keep clean using a vacuum cleaner. Sweeping or blowing stirs up dust.
- Vacuum or wash the protective clothing. Do not blow, beat or brush.

### 4.8 Safety instructions for battery packs:



Protect battery packs from water and moisture!



Do not expose battery packs to naked flame!



Do not use faulty or deformed battery packs!  
Do not open battery packs!



Do not touch or short-circuit battery packs!

Slightly acidic, flammable fluid may leak from defective Li-ion battery packs!



If battery fluid leaks out and comes into contact with your skin, rinse immediately with plenty of water. If battery fluid leaks out and comes into contact with your eyes, wash them with clean water and seek medical attention immediately.

If the machine is defective, remove the battery pack from the machine.

### Transport of li-ion battery packs:

The shipping of li-ion battery pack is subject to laws related to the carriage of hazardous goods (UN 3480 and UN 3481). Inform yourself of the currently valid specifications when shipping li-ion battery packs. If necessary, consult your freight forwarder. Certified packaging is available from Metabo.

Only send the battery pack if the housing is intact and no fluid is leaking. Remove the battery pack from the machine for sending. Prevent the contacts from short-circuiting (e.g. by protecting them with adhesive tape).

## 5. Overview

See page 2.

- 1 Clip to tighten/release the (tool-free) clamping nut manually \*
- 2 Clamping nut (tool-free) \*
- 3 Support flange
- 4 Spindle
- 5 Spindle locking button
- 6 Sliding on/off switch
- 7 Handle
- 8 Battery pack release button
- 9 Capacity indicator button
- 10 Capacity and signal indicator
- 11 Battery pack
- 12 Additional handle
- 13 Safety guard
- 14 Clamping nut \*
- 15 2-hole spanner \*
- 16 Lever for safety guard attachment\*



17 Clamping screw\*

18 Clamping ring\*

\* depending on equipment/not in scope of delivery

## 6. Initial Operation

### 6.1 Attaching the additional handle

 Always work with the additional handle attached (12)! Attach the additional handle on the left or right of the machine and secure.

### 6.2 Install safety guard

 For safety reasons, only use the guard provided for the respective accessory! Using an incorrect guard can lead to loss of control and serious injuries. See also chapter 11. Accessories!

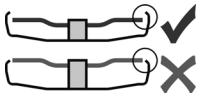

Use only accessories that are covered by at least 3.4 mm by the safety guard.

#### W 18 L 9-125 Quick:

See illustration C on page 2.

- Pull on the lever (16). Place the safety guard (13) in the position indicated.
- Release the lever and turn the safety guard until the lever engages.
- Pull on the (16) lever and turn the safety guard until the closed section is facing the operator.
- Make sure that the guard is seated securely: the lever must engage and you should not be able to turn the safety guard.

#### W 18 L 9-115, W 18 L 9-125:

See illustration D on page 2.

- Loosen the clamping screw (17) until the clamping ring (18) on the safety guard (13) expands sufficiently.
- Place the safety guard (13) in the position indicated.
- Turn the safety guard until the closed section is facing the operator.
- Tighten the clamping screw (17) firmly. Make sure that the guard is seated securely - you should not be able to turn the safety guard (13).

### 6.3 Battery pack

Charge the battery pack before use (11).

If performance diminishes, recharge the battery pack.

Instructions on charging the battery pack can be found in the operating instructions of the Metabo charger.

Battery packs have a capacity and signal display (10) (depends on design variant):

- Press the button (9), the LEDs indicate the charge level.
- If one LED is flashing, the battery pack is almost flat and must be recharged.

### 6.4 Removing and inserting the battery pack

 Hold the machine when removing and inserting the battery pack such that the on/off switch cannot be unintentionally pressed.

#### Removal:

Press the battery pack release button (8) and remove battery pack (11).

#### Inserting:

Slide in the battery pack (11) until it engages.

## 7. Attaching the grinding wheel

 Before carrying out any modifications: remove the battery pack from the machine. The machine must be switched off and the spindle at a standstill.

 For reasons of safety, attach the safety guard for cut-off grinding before performing Abrasive Cutting-Off Operations (see chapter 11. Accessories).

### 7.1 Locking the spindle

- Press in the spindle locking button (5) and turn the spindle (4) by hand until you feel the spindle locking button engage.

### 7.2 Placing the wheel in position

See illustration A on page 2.

- Fit the support flange (3) on the spindle. The flange should not turn on the spindle when properly attached.
- Place the grinding wheel on the support flange (3). The grinding wheel must lay flat on the supporting flange. The metal flange on the cut-off wheel must lay flat on the support flange.

**Note:** The support flange (3) is secured to prevent it from falling off. To remove: use some force if necessary.

### 7.3 Securing/releasing the (tool-free) clamping nut (depending on features)

 Only tighten the (tool-free) clamping nut (2) manually.

 For the machine to operate, the clip (1) must always lie flat on clamping nut (2).

#### To secure the (tool-free) clamping nut (2):

 Do not use the (tool-free) clamping nut if the accessory has a clamping shank thicker than 6 mm! In this case, use the clamping nut (14) with 2-hole spanner (15).

- Lock the spindle (see chapter 7.1).
- Flip up the clip (1) on the clamping nut.
- Fit the clamping nut (2) on the spindle (4). See illustration on page 2.
- (1) Tighten the clamping nut **on the clip manually** in a clockwise direction.
- Flip down the clip (1) again.

#### To release the (tool-free) clamping nut (2) :

- Lock the spindle (see chapter 7.1).
- Flip up the clip (1) on the clamping nut.

## en ENGLISH

- Unscrew the clamping nut (2) , turning it anticlockwise **manually** .

**Note:** If the clamping nut is very tightly secured (2), you can also use a 2-hole spanner to unscrew it.

### 7.4 Securing/releasing the clamping nut (depending on features)



#### Securing the clamping nut (14):

The 2 sides of the clamping nut are different. Screw the clamping nut onto the spindle as follows:

See illustration B on page 2.

#### - A) For thin grinding wheels:

The edge of the clamping nut (14) faces upwards so that the thin grinding wheel can be attached securely.

#### B) For thick grinding wheels:

The edge of the clamping nut (14) faces downwards so that the clamping nut can be attached securely to the spindle.

- Lock the spindle. Turn the clamping nut (14) clockwise using the 2-hole spanner (15) to secure.

#### Releasing the clamping nut:

- Lock the spindle (see chapter 7.1). Turn the clamping nut (14) anticlockwise using the 2-hole spanner (15) to unscrew.

## 8. Use

### 8.1 Switching On and Off



Always guide the machine with both hands.



Switch on first, then guide the accessory towards the workpiece.



The machine must not be allowed to draw in additional dust and shavings. When switching the machine on and off, keep it away from dust deposits. After switching off the machine, only place it down when the motor has come to a standstill.



Avoid switching on the machine accidentally: always switch it off when the battery pack is removed from the machine.



In continuous operation, the machine continues running if it is forced out of your hands. Therefore, always hold the machine with both hands using the handles provided, stand in a safe position and concentrate.

#### Machines with slide switch:

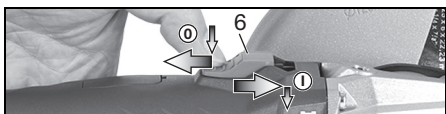

**Switching on:** Push the slide switch (6) forward. For continuous activation, now tilt downwards until it engages.

**Switching off:** Press the rear end of the slide switch (6) and release.

## 8.2 Working instructions

### Grinding:

Press down the machine evenly on the surface and move back and forth so that the surface of the workpiece does not become too hot.

Roughing: position the machine at an angle of 30° - 40° for the best working results.

### Cutting-off:



**Always work against the run of the disc (see illustration).** Otherwise there is

the danger of the machine kicking back from the cut out of control. Guide the machine evenly at a speed suitable for the material being processed. Do not tilt, apply excessive force or sway from side to side.

### Sanding:

Press down the machine evenly on the surface and move back and forth so that the surface of the workpiece does not become too hot.

### Wire brushing:

Press down the machine evenly.

## 9. Cleaning

Remove the battery pack from the machine before any adjustments, conversions or servicing are performed.

Remove the **battery pack** periodically and wipe the contact area of the battery pack and machine with a dry cloth and remove deposits. If the battery pack cannot be removed: see the Repairs chapter.

## 10. Troubleshooting

**Electronic safety shutdown The machine has SHUT DOWN by itself.** If the slew rate of the current is too high (for example, if the machine suddenly seizes or kickback occurs), the machine switches off. Switch off the machine. Switch it on again and continue to work as normal. Try to prevent the machine from seizing. See chapter 4.2.

## 11. Accessories

Use only original Metabo or CAS (Cordless Alliance System) battery packs and accessories. See page 4.

Use only accessories which fulfil the requirements and specifications listed in these operating instructions.



Always use the suitable accessory and the prescribed guard for the matching guard for the application. **See page 4.** (Illustrations are examples).

### Application:

- 1 = surface grinding
- 2 = cut-off grinding
- 3 = drilling of holes
- 4 = wire brushes
- 5 = grinding with sanding paper

### Accessories:

- 1.1 = grinding wheel
- 2.1 = cut-off wheel "metal"

- 2.2 = cut-off wheel "masonry/concrete"
- 2.3 = diamond cutting disc "masonry/concrete"
- 2.4 = dual-purpose diamond cutting discs (combined grinding and cutting disc)
- 3.1 = diamond drill bits
- 4.1 = wheel brush
- 4.2 = cup brush
- 5.1 = flap disc
- 5.2 = backing pad for sanding sheets

**prescribed guard:**

- Type A = cutting guard / guard incl cutting guard slip for cutting-off operations
- Type B = guard for grinding
- Type C = guard for grinding and cutting-off operations (combination)

**Other accessories:**(see also [www.metabo.com](http://www.metabo.com))

- A Chargers**
- B Battery pack**
- C Extraction hood clip CED 125 Clip**
- D Adjusting nut (14)**
- E Clamping nut (tool-free) (2)**

For a complete range of accessories, see [www.metabo.com](http://www.metabo.com) or the main catalogue.

**12. Repairs**

 Repairs to electrical tools must be carried out by qualified electricians ONLY!

Contact your local Metabo representative if you have Metabo power tools requiring repairs. For addresses see [www.metabo.com](http://www.metabo.com).

You can download a list of spare parts from [www.metabo.com](http://www.metabo.com).

**13. Environmental Protection**

The sanding dust generated may contain hazardous materials: do not dispose of with the household waste, but at a special collection point for hazardous waste.

Observe national regulations on environmentally compatible disposal and on the recycling of disused machines, packaging and accessories.

Battery packs must not be disposed of with regular waste. Please return faulty or used battery packs to your Metabo dealer.

Do not throw battery packs into water.

 Only for EU countries: Never dispose of power tools in your household waste! In accordance with European Guideline 2012/19/EU on used electronic and electric equipment and its implementation in national legal systems, used power tools must be collected separately and handed in for environmentally compatible recycling. Before disposal, discharge the battery pack in the power tool. Prevent the contacts from short-circuiting (e. g. by protecting them with adhesive tape).

**14. Technical Specifications**

Explanation of details on page 2 . Subject to changes serving technical progress.

- U = Voltage of battery pack
- D<sub>max</sub> = max. diameter of accessory
- t<sub>max,1</sub> = max. permitted thickness of clamping shank on accessory when using clamping nut (14)
- t<sub>max,2</sub> = max. permitted thickness of clamping shank on accessory when using "Quick" clamping nut (2)
- t<sub>max,3</sub> = grinding wheel / cut-off wheel: max. permitted thickness of accessory
- t<sub>max,4</sub> = max. permitted thickness of wheel-type wire brushes
- M = Spindle thread
- l = Length of the grinding spindle
- n = No-load speed (maximum speed)
- m = Weight (with the smallest battery pack)

Measured values determined in conformity with EN 60745.

Permitted ambient temperature during operation: -20 °C (-4°F) to 50 °C (120°F) (limited performance with temperatures below 0 °C (32°F)). Permitted ambient temperature for storage: 0 °C (32°F) to 30 °C (86°F).

--- Direct current

The technical specifications quoted are subject to tolerances (in compliance with the relevant valid standards).

** Emission values**

These values make it possible to assess the emissions from the power tool and to compare different power tools. Depending on the operating conditions, the condition of the power tool or the accessories, the actual load may be higher or lower. For assessment purposes, please allow for breaks and periods when the load is lower. Based on the adjusted estimates, arrange protective measures for the user e.g. organisational measures.

 The grinding of thinner metal sheets and other workpieces with large surfaces that easily vibrate can lead to a significantly higher overall sound emission (up to 15 dB) than the sound emission values specified. The sound radiation of such workpieces should be prevented to the greatest extent possible by means of suitable measures, such as fitting heavy, flexible damping mats. The increased sound emission must also be taken into account when assessing the risk of noise exposure and selecting suitable hearing protection.

Vibration total value (vector sum of three directions) determined in accordance with EN 60745:

- a<sub>h, SG</sub> = Vibration emission value (sanding surfaces)
- a<sub>h, DS</sub> = Vibration emission value (sanding with sanding pad)

K<sub>h, SG/DS</sub> = Uncertainty (vibration)

Typical A-effective perceived sound levels:

- L<sub>pA</sub> = Sound pressure level
- L<sub>WA</sub> = Acoustic power level

## en ENGLISH

$K_{pA}$ ,  $K_{WA}$  = Uncertainty

During operation the noise level can exceed  
80 dB(A).



**Wear ear protectors!**