

SXA 18 LTX 125 BL
SXA 18 LTX 150 BL
PowerMaxx SXA 12-125 BL
PowerMaxx SRA 12 BL
PowerMaxx SMA 12 BL



de	Originalbetriebsanleitung 5	fi	Alkuperäiset ohjeet 43
en	Original instructions 10	no	Original bruksanvisning 47
fr	Notice originale 14	da	Original brugsanvisning 51
nl	Oorspronkelijke gebruiksaanwijzing 19	pl	Instrukcja oryginalna 55
it	Istruzioni originali 24	el	Πρωτότυπο οδηγιών χρήσης 60
es	Manual original 29	hu	Eredeti használati utasítás 65
pt	Manual original 34	ru	Оригинальное руководство по эксплуатации 70
sv	Bruksanvisning i original 39	uk	Оригінальна інструкція з експлуатації 76

SXA 18 LTX 125/150 BL 18 V

PowerMaxx SXA 12-125 BL

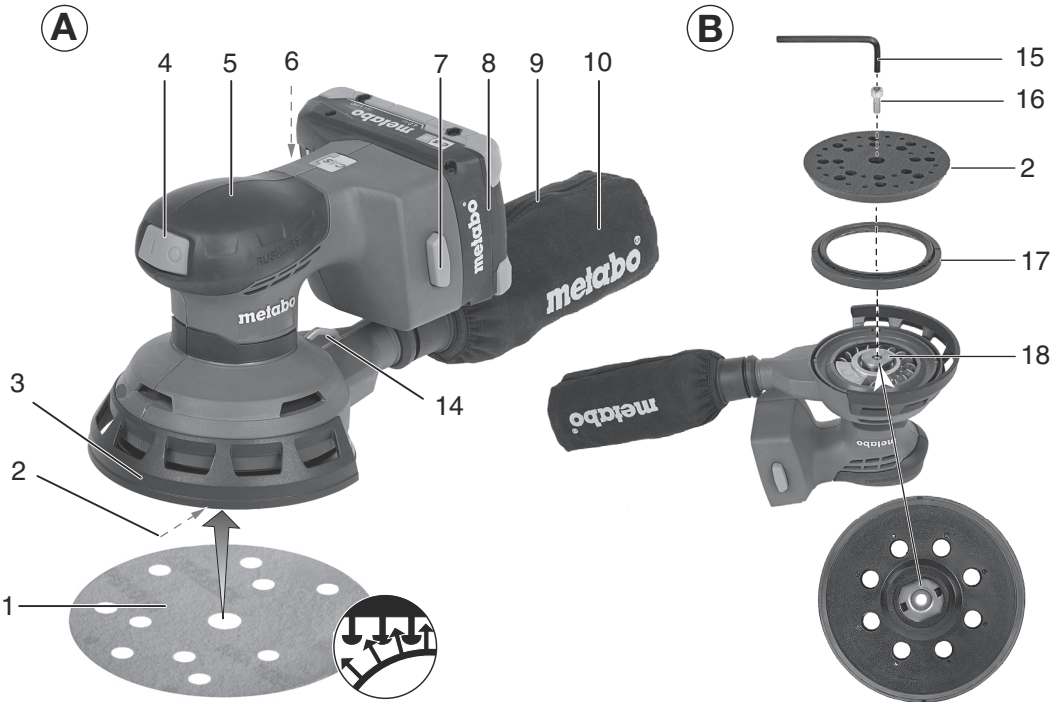

PowerMaxx SRA 12 BL

PowerMaxx SMA 12 BL

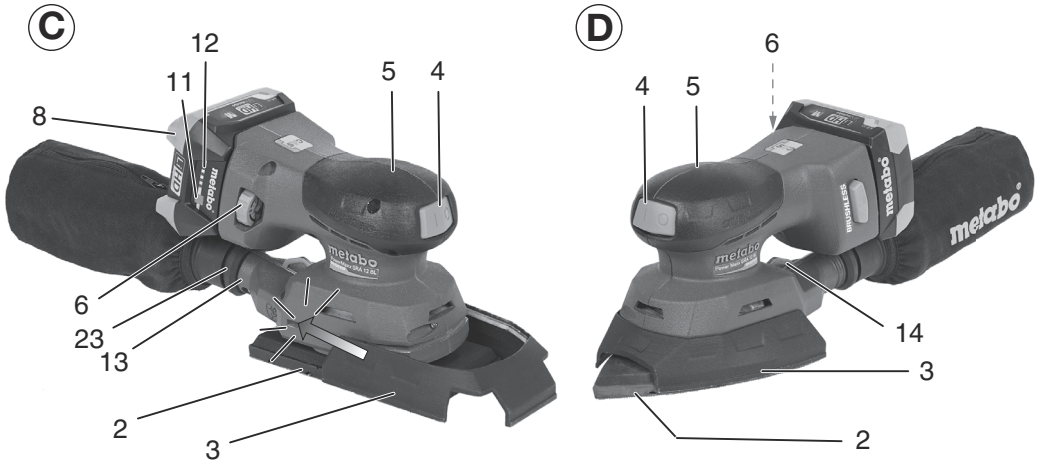

E PowerMaxx SRA 12 BL
PowerMaxx SMA 12 BL

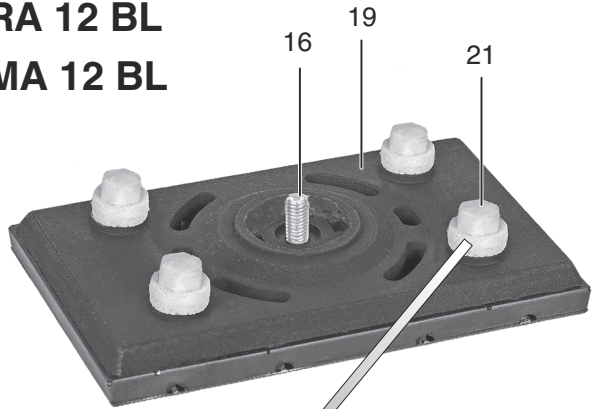

F PowerMaxx SRA 12 BL
PowerMaxx SMA 12 BL

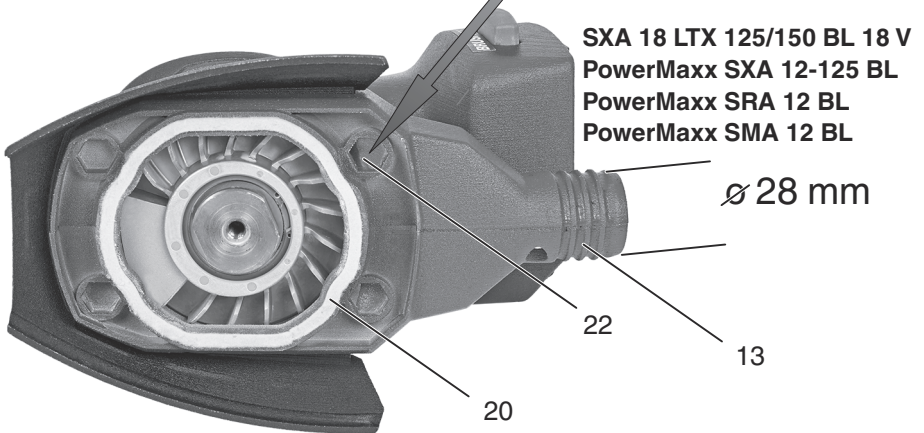

G

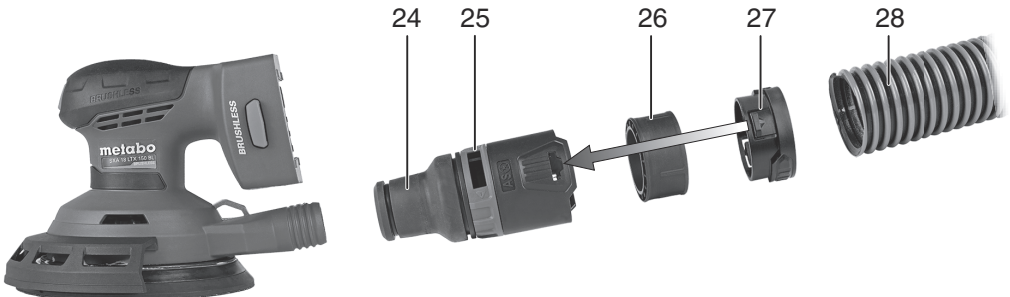

		SXA 18 LTX 125 BL *1) Serial Number: 00146..	SXA 18 LTX 150 BL *1) Serial Number: 00411..	Powermaxx SXA 12-125 BL *1) Serial Number: 02035..	Powermaxx SRA 12 BL *1) Serial Number: 02036..	Powermaxx SMA 12 BL *1) Serial Number: 02037..
U	V	18	18	12	12	12
D	mm (in)	125 (4 ¹⁵ / ₁₆)	125 (5 ²⁹ / ₃₂)	125 (4 ¹⁵ / ₁₆)	-	-
n₀	min ⁻¹ (rpm)	4000-10000	4000-10000	4000-10000	4000-10000	4000-10000
s₀	min ⁻¹ (opm)	8000-20000	8000-20000	8000-20000	8000-20000	8000-20000
S	mm (in)	2,0 (¹ / ₁₆)	3,0 (¹ / ₈)	2,0 (¹ / ₁₆)	2,0 (¹ / ₁₆)	2,0 (¹ / ₁₆)
m	kg (lbs)	1,7 (3,7)	1,4 (3,1)	1,4 (3,1)	1,4 (3,1)	1,4 (3,1)
a_h/K_h	m/s ²	1,1 / 1,5	8,9 / 1,5	2,2 / 1,5	2,7 / 1,5	2,3 / 1,5
L_{pA}/K_{pA}	dB(A)	67 / 3	86 / 3	71 / 3	71 / 3	71 / 3
L_{WA}/K_{WA}	dB(A)	78 / 3	97 / 3	82 / 3	82 / 3	82 / 3

 *2) 2014/30/EU, 2006/42/EC, 2011/65/EU
 *3) EN 62841:2015, EN 62841-2-4:2014, EN IEC 63000:2018

2022-08-16, Bernd Fleischmann
 Direktor Produktentstehung & Qualität (Vice President Product Engineering & Quality)
 *4) Metabowerke GmbH - Metabo-Allee 1 - 72622 Nuertingen, Germany

ppa. B.F.

Original instructions

1. Declaration of Conformity

We, being solely responsible: Hereby declare that these random orbital sanders, identified by type and serial number *1), meet all relevant requirements of directives *2) and standards *3). Technical documents for *4) - see page 3.

For UK only:

UK We as manufacturer and authorized person to **CA** compile the technical file, see *4) on page 3, hereby declare under sole responsibility that these random orbital sanders, identified by type and serial number *1) on page 3, fulfill all relevant provisions of following UK Regulations S.I. 2016/1091, S.I. 2008/1597, S.I. 2012/3032 and Designated Standards EN 62841:2015, EN 62841-2-4:2014, EN IEC 63000:2018.

2. Specified Conditions of Use

The Random Orbit Sanders are suited for dry grinding of flat and curved surfaces, wood, plastics, NF metals, sheet steel and similar, primed and painted surfaces.

The user bears sole responsibility for any damage caused by inappropriate use.

Generally accepted accident prevention regulations and the enclosed safety information must be observed.

3. General Safety Information



For your own protection and for the protection of your power tool, pay attention to all parts of the text that are marked with this symbol!



WARNING – Read the operating instructions to reduce the risk of injury.



WARNING – Read all safety warnings, instructions, illustrations and specifications provided with this power tool. Failure to follow all instructions listed below may result in electric shock, fire and/or serious injury.

Keep all safety instructions and information for future reference.

Always include these documents when passing on your power tool.

4. Special safety instructions

Wear ear protectors when working for long periods of time. High noise levels over a prolonged period of time may affect your hearing. Hold the machine from the handles provided.

Reducing dust exposure:



WARNING - Some dust created by power sanding, sawing, grinding, drilling, and other construction activities contains chemicals known to

cause cancer, birth defects or other reproductive harm. Some examples of these chemicals are:

- Lead from lead-based paints,
- Crystalline silica from bricks and cement and other masonry products, and
- Arsenic and chromium from chemically treated lumber.

Your risk from these exposures varies, depending on how often you do this type of work. To reduce your exposure to these chemicals: work in a well-ventilated area, and work with approved safety equipment, such as those dust masks that are specially designed to filter out microscopic particles.

This also applies to dust from other materials such as some timber types (like oak or beech dust), metals, asbestos. Other known diseases are e.g. allergic reactions, respiratory diseases. Do not let dust enter the body.

Observe the relevant guidelines and national regulations for your material, staff, application and place of application (e.g. occupational health and safety regulations, disposal).

Collect the particles generated at the source, avoid deposits in the surrounding area.

Use suitable accessories for special work. In this way, fewer particles enter the environment in an uncontrolled manner.

Use a suitable extraction unit.

Reduce dust exposure with the following measures:

- do not direct the escaping particles and the exhaust air stream towards yourself or nearby persons or towards dust deposits,
- use an extraction unit and/or air purifiers,
- ensure good ventilation of the workplace and keep it clean using a vacuum cleaner. Sweeping or blowing stirs up dust.
- Vacuum or wash protective clothing. Do not blow, beat or brush protective gear.

Safety instructions for battery packs:



Protect battery packs from water and moisture!



Do not expose battery packs to fire!

Do not use faulty or deformed battery packs!

Do not open battery packs!

Do not touch or short circuit battery pack contacts!



A slightly acidic, flammable fluid may leak from defective Li-ion battery packs!



If battery fluid leaks out and comes into contact with your skin, rinse immediately with plenty of water. If battery fluid leaks out and comes into contact with your eyes, wash them with clean water and seek medical attention immediately!

If the machine is defective, remove the battery pack from the machine.

Remove the battery pack from the machine before making any adjustments, changing tools, maintaining or cleaning.

Make sure that the tool is switched off before fitting the battery pack.

Keep hands away from the rotating tool!

Remove chips and similar material only when the machine is at a standstill.

Secure the workpiece to prevent slipping or rotation (e.g. by securing with screw clamps).

Transport of li-ion battery packs:

The shipping of li-ion battery pack is subject to laws related to the carriage of hazardous goods (UN 3480 and UN 3481). Inform yourself of the currently valid specifications when shipping li-ion battery packs. If necessary, consult your freight forwarder. Certified packaging is available from Metabo.

Only send the battery pack if the housing is intact and no fluid is leaking. Remove the battery pack from the machine for sending. Prevent the contacts from short-circuiting (e.g. by protecting them with adhesive tape).

5. Overview

See page 2.

- 1 Sanding disc
- 2 Sanding plate
- 3 Removable protector
- 4 Toggle switch
- 5 Handle
- 6 Adjustment wheel for selecting oscillating frequency
- 7 Battery pack release button
- 8 Battery pack *
- 9 Zipper
- 10 Textile dust bag
- 11 Capacity indicator button
- 12 Capacity and signal indicator
- 13 Ejection nozzle
- 14 Metal eyelet (for fall protection)
- 15 Hexagon wrench
- 16 Locking screw of the grinding plate
- 17 Disc brake
- 18 Drive plate
- 19 Sanding plate
- 20 Felt ring
- 21 Swivel bolt
- 22 Housing mount
- 23 Rubber sleeve
- 24 Connection sleeve for 32/35 mm
- 25 Rotating ring
- 26 Threaded ring
- 27 Quick-release catch
- 28 Suction hose

* not in scope of delivery

6. Initial Operation

6.1 Battery pack

Charge the battery pack (8) before use.

Recharge the battery pack if performance diminishes.

Instructions on charging the battery pack can be found in the operating instructions of the Metabo charger.

Li-Ion battery packs “Li-Power“ have a capacity and signal indicator (12):

- Press the button (11), the LEDs indicate the charge level.
- The battery pack is almost flat and must be recharged if one LED is flashing.

6.2 Removing and inserting the battery pack

 Hold the machine when removing and inserting the battery pack so that the on/off switch cannot be unintentionally pressed.

Removing:

Press the battery pack release button (7) and pull the battery pack (8) forwards.

Inserting:

Slide in the battery pack (8) until it engages.

6.3 Installation of sanding disc

Simple attachment and removal thanks to the hook and loop fastening.

Simply press on the sanding sheet so that the holes in the sanding sheet (1) are aligned with the sanding plate (2).

6.4 Attach the connection sleeve

To improve the guidance behaviour when using a vacuum cleaner, the suction force can be regulated by means of a connection sleeve with adjustable air inlet.

Order no.: 635409000
for hose with diameter 32/35 mm

Fitting see p. 3 fig. G:

Unscrew the connected connection sleeve in clockwise direction: Slide the quick-release catch (27) onto the hose end of the vacuum cleaner (28) and screw on the threaded ring (26) in anti-clockwise direction. Insert the hose end with the quick-release catch into the sleeve until the catch engages.

Order no.: 635401000
Sleeve with hose 27 mm fitted

The suction force can be reduced by turning the red ring (25).

7. Use

7.1 On/Off switch, continuous activation

Press the toggle switch (4) to switch on the machine.

Press the toggle switch (4) again to stop the machine.

7.2 Set speed / oscillating frequency

Set the speed/ oscillating frequency on the adjustment wheel (6). The best way to determine the ideal setting is through a practical trial.

7.3 Removable protector

is used to protect the sanding plate (2). For sanding close to edges and protection against adjacent surfaces it can be removed by lifting the side ends slightly and removing it from the groove. Now pull the protector (3) away towards the front. In order to reattach the protector (3), push the protector onto the machine housing and click it into place at the groove. (See fig. C)

7.4 Safety hook for fall protection

In order to protect the tool against falling, a fall protection can be attached to the Metal eyelet (for fall protection) (14).

7.5 Replacing the sanding plates

For the PowerMaxx SRA 12 BL and PowerMaxx SMA 12 BL, the sanding plates (19) are interchangeable. See Section 8.

7.6 Dust extraction

To optimise the dust extraction performance, fit the sanding sheet in such a way that the holes of the sanding sheet (1) and sanding disc (2) or sanding plate (19) are aligned.

Note: We recommend connecting a suitable extraction device when sanding abrasive material (e.g. plaster, etc.).

Own extraction units:

Place the textile dust bag (10) with the rubber sleeve (23) onto the ejection nozzle (13). Pull the textile dust bag (10) backwards to remove it. Attach the textile dust bag (10) with the zipper (9) pointing upwards. (See fig. A)

For optimum extraction performance, empty the textile dust bag (10) in good time.

Third-party extraction units:

Connect a suitable extraction device to the ejection nozzle (13) using the connection sleeve 630798000.

7.7 Metal eyelet for fall protection

 The metal eyelet (14) is designed for attaching a suitable, original Metabo tool fall protection securing lanyard. Check the metal eyelet for damage prior to each use. Read and follow the operating instructions of the tool securing lanyard! After each fall, have the machine checked for damage by a trained specialist and repaired if necessary.

8. Cleaning, Maintenance

Emptying the textile dust bag: Remove the rubber sleeve (23) of the textile dust bag (10) from the ejection nozzle (13). Empty the textile dust bag (10) through the opened zipper (9), if needed clean with extraction device. The textile dust bag has a

spring so that it can easily be emptied by tapping on the closed side.

The clean the machine regularly, frequently and thoroughly. This includes vacuum cleaning the ventilation louvres on the motor.

Replace worn sanding disc (2) or sanding plate (19) (see fig. B)

Note: If abrasive material (e.g. filled or painted surfaces, etc.) is being sanded, the sanding disc inevitably wears faster.



The fixing screw (16) can be hot after use!

- Use the hexagon spanner (15) to unscrew the fixing screw (16) of the sanding disc.
 - Remove the sanding disc (2)/sanding plate (19).
 - For sanding plate (as replacement), refer to the Accessories chapter.
 - **SXA 18 LTX 125/150 BL / PowerMaxx SXA 12-125 BL:** Position sanding plate (2) and turn it until it engages on the drive plate (18).
 - **PowerMaxx SRA/SMA 12-125 BL:** Position the sanding plate (19): the swivel bolts of the sanding plate (19) must engage in the housing mount (22). (See fig. E)
 - Insert locking screw (16) again and tighten.
- Replacing the disc brake (17) / felt ring (20) (see fig. B and F)**

If the idle speed of the support plate increase in the course of time, the disc brake (17) or the felt ring (20) is worn and must be replaced.

Note: If abrasive material (e.g. filled or painted surfaces etc.) is being sanded, the disc brake and felt ring inevitable wear faster.

- Use the hexagon spanner (15) to unscrew the fixing screw (16) of the sanding disc (2) or the sanding plate (19).
- Remove the sanding disc (2) or sanding plate (19).
- Replace the old braking ring (17) or felt ring (20) with the new braking ring (see pages 2 and 3), ensuring that the new braking ring/felt ring is in the same position as the old one. Ensure that the position of the marking on the braking ring is correct. The felt ring has no marking.
- For correct operation, the contact surface of both the braking and the felt ring to the sanding plate must be coated with a thin film of grease.
- **SXA 18 LTX 125/150 BL / PowerMaxx SXA 12-125 BL:** Position sanding plate (2) and turn it until it engages on the drive plate (18).
- **PowerMaxx SRA/SMA 12-125 BL:** Position the sanding plate (19): the swivel bolts of the sanding plate (19) must engage in the housing mount (22).
- Insert locking screw (16) again and tighten.

Do not press the device too firmly against the surface being sanded. This does not improve, but rather impairs, the sanding performance.

For optimum extraction performance, empty the textile dust bag (10) in good time.

Use a suitable sanding disc to achieve the best possible work results:

9. Accessories

Note: Metabo accessories are adapted to suit the machine's hook and loop-type fastening. This increases the service life of the hook and loop-type fastening.

Use only original Metabo or CAS (Cordless Alliance System) battery packs and accessories.

Battery packs marked with CAS are 100% compatible with CAS devices (Cordless Alliance System).

Use only accessories that fulfil the requirements and specifications listed in these operating instructions.

If you need any accessories, check with your dealer.

- A Battery packs with different capacities. Buy battery packs only with voltage suitable for your power tool.

12 V

Order no.: 625349000 4.0 Ah (LiHD)

18 V

Order no.: 625367000 4.0 Ah (LiHD)
etc.

- B Chargers:
ASC 55, ASC 145
etc.

- C Sleeve: fitting see chapter 6.4
Order no.: 635409000
for hose with diameter 32/35 mm
Order no.: 635401000
Sleeve with hose 27 mm fitted

Chargers are only suitable for charging Metabo and CAS (Cordless Alliance System) battery packs.

For a complete range of accessories, see www.metabo.com or the catalogue.

10. Repairs

 Repairs to electrical tools must ONLY be carried out by qualified electricians!

Contact your local Metabo representative if you have Metabo power tools requiring repairs. For addresses see www.metabo.com.

You can download a list of spare parts from www.metabo.com.

11. Environmental Protection

Observe national regulations on environmentally compatible disposal and on the recycling of disused machines, packaging and accessories.

Packaging materials must be disposed of according to their labelling in accordance with municipal guidelines. Further information can be found at www.metabo.com in the "Service" section.

 Only for EU countries: never dispose of power tools in your household waste!
According to European Directive 2012/19/EU on Waste from Electric and Electronic Equipment and implementation in national law, used power

tools must be collected separately and recycled in an environmentally-friendly manner.

12. Technical Specifications

Explanatory notes on the specifications on page 3. Changes due to technological progress reserved.

D = Diameter of sanding plate
n₀ = Idle speed (setting wheel)
s₀ = Oscillating frequency at idle speed (setting wheel)
S = Oscillating circuit diameter
m = Weight without battery pack

Measured values determined in conformity with EN 62841.

Permitted ambient temperature during operation: -20 °C to 50 °C (limited performance with temperatures below 0 °C). Permitted ambient temperature for storage: 0 °C to 30 °C
== direct current

The technical specifications quoted are subject to tolerances (in compliance with relevant valid standards).

Emission values

These values make it possible to assess the emissions from the power tool and to compare different power tools. The actual load may be higher or lower depending on operating conditions, the condition of the power tool or the accessories used. Please allow for breaks and periods when the load is lower for assessment purposes. Arrange protective measures for the user, such as organisational measures based on the adjusted estimates.

Vibration total value (vector sum of three directions) determined in accordance with EN 62841:

a_h = Vibration emission value (surface grinding)
K_h = Uncertainty (vibration)

Typical A-weighted sound levels:

L_{pa} = sound-pressure level
L_{WA} = Acoustic power level
K_{pA}, K_{WA} = Uncertainty

The noise level can exceed 80 dB(A) during operation.

 **Wear ear protectors!**