

metabo®

PROFESSIONAL POWER TOOL SOLUTIONS

BS 18 LTX BL I
BS 18 LTX BL Q I
SB 18 LTX BL I
SB 18 LTX BL Q I

BS 18 LTX-3 BL I
BS 18 LTX-3 BL Q I
SB 18 LTX-3 BL I
SB 18 LTX-3 BL Q I



en Operating Instructions 7
fr Mode d'emploi 12

es Manual original 18

A

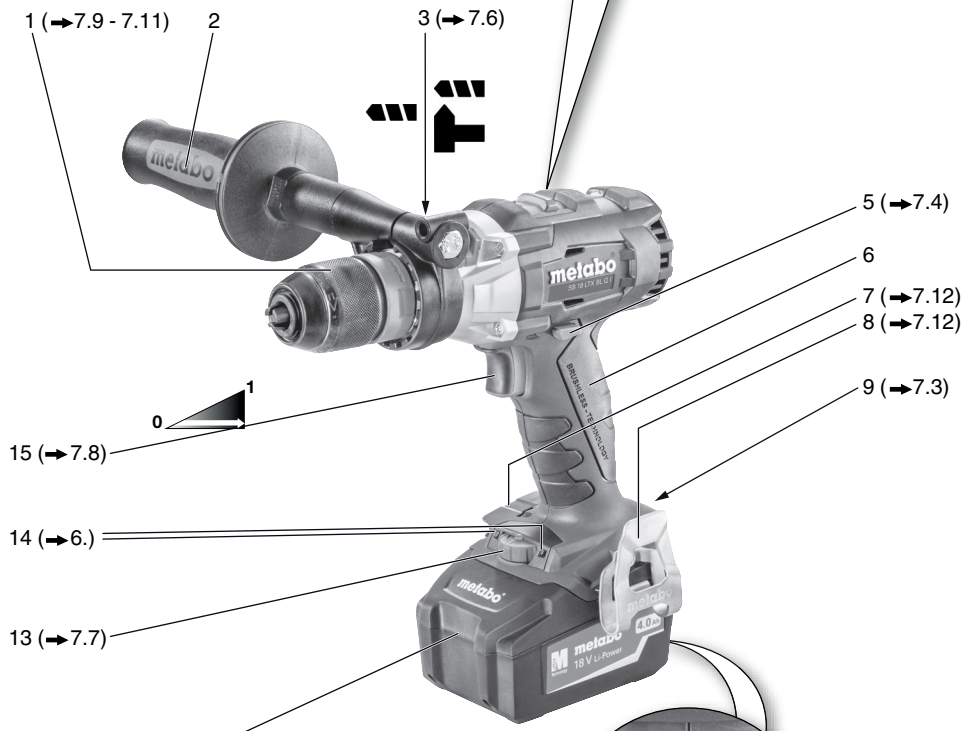
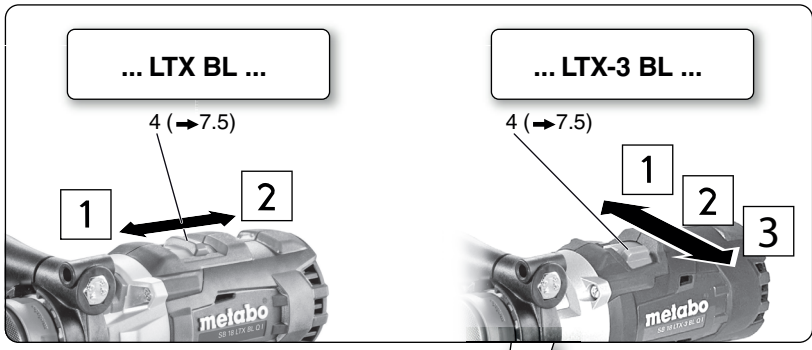

12 (→7.3)	18 V	Li-Power	4,0 Ah	6.25591
	18 V	Li-Power	5,2 Ah	6.25592
	18 V	LiHD	5,5 Ah	6.25342
				etc.

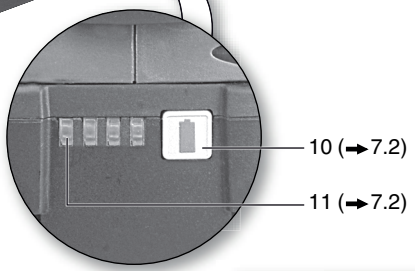

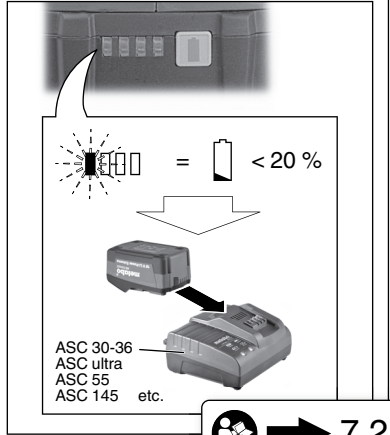
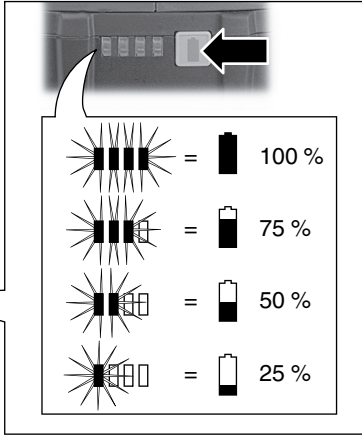
B

→ 7.2

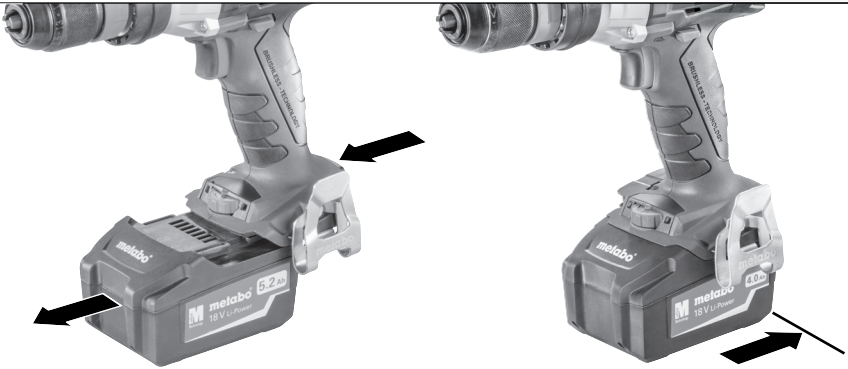
C

→ 7.3

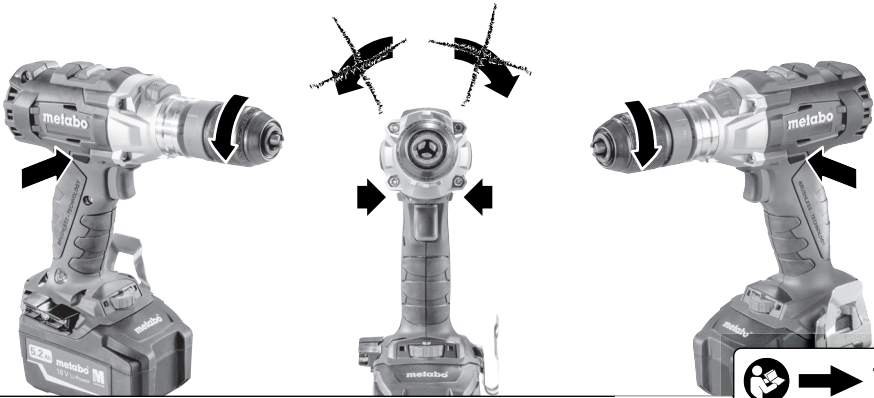
D

→ 7.4

E

... LTX BL ...

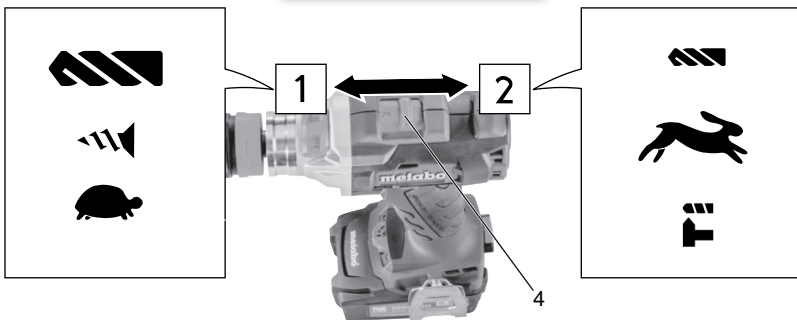

... LTX-3 BL ...

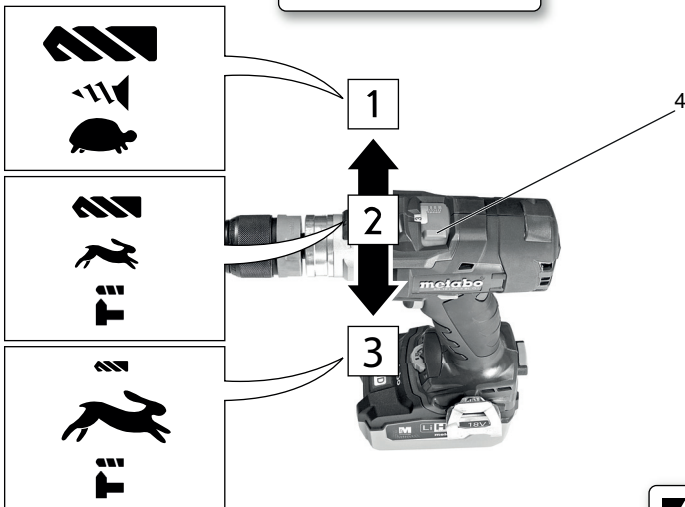

F



 = Impuls

1...10 = Nm... Nm

 = max. Nm



G

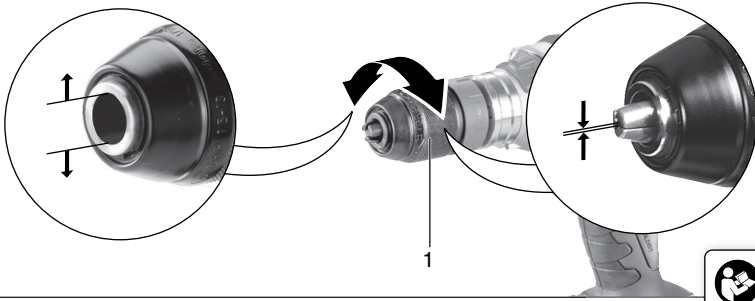

 → 7.9

H

... BL Q ...

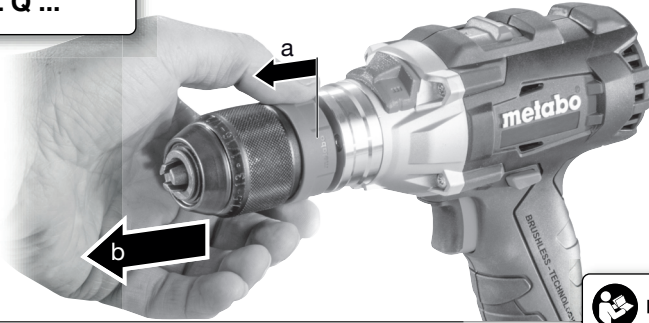

 → 7.11

I

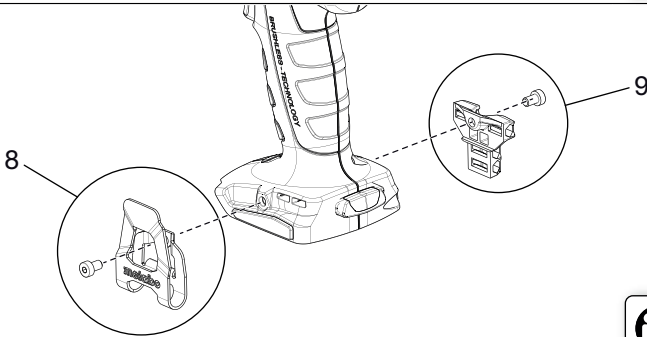

 → 7.12

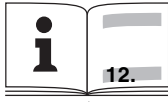

		BS 18 LTX BL I Serial Number: 02358..		BS 18 LTX BL Q I Serial Number: 02359..		SB 18 LTX BL I Serial Number: 02360..		SB 18 LTX BL Q I Serial Number: 02361..		BS 18 LTX-3 BL I Serial Number: 02354..		BS 18 LTX-3 BL Q I Serial Number: 02355..		SB 18 LTX-3 BL I Serial Number: 02356..		SB 18 LTX-3 BL Q I Serial Number: 02357..	
U	V	18															
n₀	/min, rpm	1	0 - 550						0 - 500								
		2	0 - 2000						0 - 2050								
		3	-						0 - 3800								
M₁	Nm (in-lbs)	65 (575)						60 (531)									
M₂	Nm (in-lbs)	65 (575)						65 (575)									
M₃	Nm (in-lbs)	130 (1150)						120 (1062)									
M₄	Nm (in-lbs)	1	3 - 20 (26.6 - 177)						1 - 20 (8.9 - 177)								
		2	1 - 9 (8.9 - 79.7)						1 - 8 (8.9 - 70.8)								
		3	-						7 (62.0)								
D_{1 max}	mm (in)	13 (1/2)															
D_{2 max}	mm (in)	68 (2 11/16)						65 (2 1/2)									
D_{3 max}	mm (in)	2/3	-		16 (5/8)		-		16 (5/8)								
s	/min, bpm	-		38000				-		48000							
m	kg (lbs)	2,3 (5.1)		2,4 (5.3)		2,4 (5.3)		2,6 (5.7)									
G	UNF(in)	1/2" - 20 UNF	-		1/2" - 20 UNF	-		1/2" - 20 UNF	-		1/2" - 20 UNF	-					
D_{max}	mm (in)	13 (1/2)															
a_{h, ID/K_{h, ID}}	m/s²	-		17,3 / 157				-		17,7 / 1,5							
a_{h, D/K_{h, D}}	m/s²	< 2,5 / 1,5		< 2,5 / 1,5				3,8 / 1,5									
a_{h, S/K_{h, S}}	m/s²	< 2,5 / 1,5															
L_{pA/K_{pA}}	dB(A)	77 / 3		98 / 3		71 / 3		71 / 3									
L_{WA/K_{WA}}	dB(A)	88 / 3		109 / 3		82 / 3		82 / 3									



Operating Instructions

1. Specified Conditions of Use

The cordless drills/screwdrivers and cordless hammer drills are suitable for drilling without impact in metal, wood, plastic and similar materials as well as for screwdriving and thread tapping.

The cordless hammer drills are also suitable for impact drilling in masonry, brickwork and stone.

The user bears sole responsibility for any damage caused by inappropriate use.

Generally accepted accident prevention regulations and the enclosed safety information must be observed.

2. General Safety Information



For your own protection and for the protection of your power tool, pay attention to all parts of the text that are marked with this symbol!



WARNING – Reading the operating instructions will reduce the risk of injury.

Pass on your power tool only together with these documents.

General Power Tool Safety Warnings



WARNING – Read all safety warnings, instructions, illustrations and specifications provided with this power tool. Failure to follow all instructions listed below may result in electric shock, fire and/or serious injury.

Save all safety warnings and information for future reference! The term "power tool" in the safety warnings refers to your mains-operated (corded) power tool or battery-operated (cordless) power tool.

2.1 Work area safety

- Keep work area clean and well lit.** Cluttered or dark areas invite accidents.
- Do not operate power tools in explosive atmospheres, such as in the presence of flammable liquids, gases or dust.** Power tools create sparks which may ignite the dust or fumes.
- Keep children and bystanders away while operating a power tool.** Distractions can cause you to lose control.

2.2 Electrical safety

- Power tool plugs must match the outlet.** Never modify the plug in any way. Do not use any adapter plugs with earthed (grounded) power tools. Unmodified plugs and matching outlets will reduce risk of electric shock.
- Avoid body contact with earthed or grounded surfaces, such as pipes, radiators, ranges and refrigerators.** There is an increased

risk of electric shock if your body is earthed or grounded.

- Do not expose power tools to rain or wet conditions.** Water entering a power tool will increase the risk of electric shock.
- Do not abuse the power tool. Never use the cord for carrying, pulling or unplugging the power tool. Keep cord away from heat, oil, sharp edges or moving parts.** Damaged or entangled cords increase the risk of electric shock.
- When operating a power tool outdoors, use an extension cord suitable for outdoor use.** Use of a cord suitable for outdoor use reduces the risk of electric shock.
- If operating a power tool in a damp location is unavoidable, use a residual current device (RCD) protected supply.** Use of an RCD reduces the risk of electric shock.

2.3 Personal safety

- Stay alert, watch what you are doing and use common sense when operating a power tool. Do not use a power tool while you are tired or under the influence of drugs, alcohol or medication.** A moment of inattention while operating power tools may result in serious personal injury.
- Use personal protective equipment. Always wear eye protection.** Protective equipment such as a dust mask, non-skid safety shoes, hard hat or hearing protection used for appropriate conditions will reduce personal injuries.
- Prevent unintentional starting. Ensure the switch is in the off-position before connecting to power source and/or battery pack, picking up or carrying the tool.** Carrying power tools with your finger on the switch or energising power tools that have the switch on invites accidents.
- Remove any adjusting key or wrench before turning the power tool on.** A wrench or a key left attached to a rotating part of the power tool may result in personal injury.
- Do not overreach. Keep proper footing and balance at all times.** This enables better control of the power tool in unexpected situations.
- Dress properly. Do not wear loose clothing or jewellery. Keep your hair, clothing and gloves away from moving parts.** Loose clothes, jewellery or long hair can be caught in moving parts.
- If devices are provided for the connection of dust extraction and collection facilities, ensure these are connected and properly used.** Use of dust collection can reduce dust-related hazards.
- Do not let familiarity gained from frequent use of tools allow you to become complacent and ignore tool safety principles.** A careless action can cause severe injury within a fraction of a second.

2.4 Power tool use and care

- a) **Do not force the power tool. Use the correct power tool for your application.** *The correct power tool will do the job better and safer at the rate for which it was designed.*
- b) **Do not use the power tool if the switch does not turn it on and off.** *Any power tool that cannot be controlled with the switch is dangerous and must be repaired.*
- c) **Disconnect the plug from the power source and/or remove the battery pack, if detachable, from the power tool before making any adjustments, changing accessories, or storing power tools.** *Such preventive safety measures reduce the risk of starting the power tool accidentally.*
- d) **Store idle power tools out of the reach of children and do not allow persons unfamiliar with the power tool or these instructions to operate the power tool.** *Power tools are dangerous in the hands of untrained users.*
- e) **Maintain power tools and accessories with care. Check for misalignment or binding of moving parts, breakage of parts and any other condition that may affect the power tool's operation. If damaged, have the power tool repaired before use.** *Many accidents are caused by poorly maintained power tools.*
- f) **Keep cutting tools sharp and clean.** *Properly maintained cutting tools with sharp cutting edges are less likely to bind and are easier to control.*
- g) **Use the power tool, accessories and tool bits etc. in accordance with these instructions, taking into account the working conditions and the work to be performed.** *Use of the power tool for operations different from those intended could result in a hazardous situation.*
- h) **Keep handles and grasping surfaces dry, clean and free from oil and grease.** *Slippery handles and grasping surfaces do not allow safe handling and control of the tool in unexpected situations.*

2.5 Battery tool use and care

- a) **Recharge only with the charger specified by the manufacturer.** *A charger that is suitable for one type of battery pack may create a risk of fire when used with another battery pack.*
- b) **Use power tools only with specifically designated battery packs.** *Use of any other battery packs may create a risk of injury and fire.*
- c) **When battery pack is not in use, keep it away from other metal objects, like paper clips, coins, keys, nails, screws or other small metal objects, that can make a connection from one terminal to another.** *Shorting the battery terminals together may cause burns or a fire.*
- d) **Under abusive conditions, liquid may be ejected from the battery; avoid contact. If contact accidentally occurs, flush with water. If liquid contacts eyes, additionally seek medical help.** *Liquid ejected from the battery may cause irritation or burns.*

- e) **Do not use a battery pack or tool that is damaged or modified.** *Damaged or modified batteries may exhibit unpredictable behaviour resulting in fire, explosion or risk of injury.*
- f) **Do not expose a battery pack or tool to fire or excessive temperature.** *Exposure to fire or temperature above 130 °C (265 °F) may cause explosion.*
- g) **Follow all charging instructions and do not charge the battery pack or tool outside the temperature range specified in the instructions.** *Charging improperly or at temperatures outside the specified range may damage the battery and increase the risk of fire.*

2.6 Service

- a) **Have your power tool serviced by a qualified repair person using only identical replacement parts.** *This will ensure that the safety of the power tool is maintained.*
- b) **Never service damaged battery packs.** *Service of battery packs should only be performed by the manufacturer or authorized service providers.*

3. Special safety instructions

Wear ear protectors when impact drilling (machines with the designation SB). Exposure to noise can cause hearing loss.

Use the additional handle supplied with the tool. Loss of control can cause personal injury.

Brace the power tool properly before use. This tool produces a high output torque and without properly bracing the tool during operation, loss of control may occur resulting in personal injury.

Hold the power tool by insulated gripping surfaces, when performing an operation where the cutting accessory may contact hidden wiring. Cutting accessory contacting a "live" wire may make exposed metal parts of the power tool "live" and could give the operator an electric shock.

Safety instructions when using long drill bits:

- a) **Never operate at higher speed than the maximum speed rating of the drill bit.** At higher speeds, the bit is likely to bend if allowed to rotate freely without contacting the workpiece, resulting in personal injury.
- b) **Always start drilling at low speed and with the bit tip in contact with the workpiece.** At higher speeds, the bit is likely to bend if allowed to rotate freely without contacting the workpiece, resulting in personal injury.
- c) **Apply pressure only in direct line with the bit and do not apply excessive pressure.** Bits can bend causing breakage and loss of control, resulting in personal injury.

Ensure that the spot where you wish to work is free of **power cables, gas lines or water pipes** (e.g. using a metal detector).

Always hold the machine with both hands on the designated handles, take a secure stance and concentrate on the work.



Protect battery packs from water and moisture!



Do not expose battery packs to fire!

Do not use faulty or deformed battery packs!

Do not open battery packs!

Do not touch or short circuit battery pack contacts!



A slightly acidic, flammable fluid may leak from defective Li-ion battery packs!



If battery fluid leaks out and comes into contact with your skin, rinse immediately with plenty of water. If battery fluid leaks out and comes into contact with your eyes, wash them with clean water and seek medical attention immediately!

If the machine is defective, remove the battery pack from the machine.

Remove the battery pack from the machine before making any adjustments, changing tools, maintaining or cleaning.

Make sure that the tool is switched off before fitting the battery pack.

Keep hands away from the rotating tool!

Remove chips and similar material only when the machine is at a standstill.

Secure the workpiece to prevent slipping or rotation (e.g. by securing with screw clamps).

LED light (14): do not observe the LED radiation directly with optical instruments.



CAUTION Do not stare at operating lamp.

Additional Warnings:

⚠ WARNING Some dust created by power sanding, sawing, grinding, drilling, and other construction activities contains chemicals known to cause cancer, birth defects or other reproductive harm. Some examples of these chemicals are:

- Lead from lead-based paints,
- Crystalline silica from bricks and cement and other masonry products, and
- Arsenic and chromium from chemically treated lumber.

Your risk from these exposures varies, depending on how often you do this type of work. To reduce your exposure to these chemicals: work in a well ventilated area, and work with approved safety equipment, such as those dust masks that are specially designed to filter out microscopic particles.

Transport of li-ion battery packs:

The shipping of li-ion battery pack is subject to laws related to the carriage of hazardous goods (UN 3480 and UN 3481). Inform yourself of the currently valid specifications when shipping li-ion battery packs. If necessary, consult your freight forwarder. Certified packaging is available from Metabo.

Only send the battery pack if the housing is intact and no fluid is leaking. Remove the battery pack from the machine for sending. Prevent the contacts from short-circuiting (e.g. by protecting them with adhesive tape).

4. Symbols

V volts

— direct current

n_0 rated speed

.. /min revolutions per minute

rpm revolutions per minute

5. Figures

Illustrations are provided at the beginning of the operating instructions.

Symbol explanation:

Movement direction

Drill bit

Slow

Fast

First gear

Second gear

Third gear

Screws

Drills, screws, threaded rods

Impact drilling

Nm Torque

6. Overview

Fig. A

- 1 Keyless chuck
- 2 Additional handle
- 3 Slide switch (normal drilling, impact drilling) *
- 4 Gear switch
- 5 Rotation selector switch (rotation setting, transport lock) - both sides of the machine
- 6 Handle
- 7 Bit depot *
- 8 Belt hook *
- 9 Battery pack release button
- 10 Capacity indicator button
- 11 Capacity and signal indicator
- 12 Battery pack
- 13 Setting wheel for
 - Pulse function
 - Torque control
 - max. torque
- 14 LED lamp (Working light and red warning lamp)
- 15 Trigger switch

*equipment-specific

7. Use

7.1 Electronic safety shutdown (...LTX BL...)

In case of sudden rotation of the power tool around the drill axis, e.g. due to catching/jamming of the accessory, the machine switches off automatically - for better control of the machine and high user protection compared to machines without this function.

The shutdown is indicated by a single red flashing of the LED light (14) and a single beep.

7.2 Battery pack, capacity and signal indicator → Fig. B

Charge the battery pack before use.

Recharge the battery pack if performance diminishes.

Instructions on charging the battery pack can be found in the operating instructions of the Metabo charger.

7.3 Removing and inserting the battery pack → Fig. C

7.4 Setting the direction of rotation, engaging the transporting safety device (switch-on lock) → Fig. D

7.5 Select the gear → Fig. E

 Do not set the gear switch (4) unless the motor has stopped completely!

7.6 Set drill, hammer drill → Fig. A

Activate slide switch (3).

7.7 Setting torque control, maximum torque, pulse function

 Do not work for long periods with pulse function switched on! (The motor can overheat.)

→ Fig. F

Set the desired operating mode at the setting wheel (13):

1...10 = Torque control

 = maximum torque

 = Pulse function

7.8 Switching On/Off, setting the speed → Fig. A

Switching on, speed: press the trigger switch (15). Press in the trigger switch to increase the rotational speed.

Switching off: release the trigger switch (15). Note: the noise that the machine makes when it switches off is due to the design (quick stop) and has no influence on the function or the service life of the machine.

7.9 Keyless chuck → Fig. G

With a soft tool shank, retightening may be required after a short drilling period.

Instructions for machines with the designation SB...:

1. The grating sound which may be heard after opening the chuck is functional and is stopped by turning the sleeve in the opposite direction.

2. Clamping the tool:

Turn sleeve in direction "GRIP, ZU" until the noticeable mechanical resistance has been overcome.

Caution! The tool is not yet clamped! Keep turning the sleeve (it must "**click**" when turning), until it cannot be turned any further - **only now** is the tool **securely** clamped.

Cleaning: from time to time, hold the machine vertically with the chuck facing downwards and turn the sleeve fully in the direction "GRIP, ZU" and then turn fully in the direction "AUF, RELEASE". The dust collected falls from the keyless chuck.

7.10 Unscrewing the drill chuck (only for machines without quick change system Quick)

The user cannot unscrew and screw on the chuck. Contact the customer service.

7.11 Chuck with quick-change system Quick (for machines with the designation ...BL Q...) → Fig. H.

To remove: Push the interlock ring forward (a), advance and pull off the chuck (b).

To fit: push the interlock ring forward and move the chuck as far as the limit stop on the drill spindle.

7.12 Fitting the belt hook (equipment-specific) / bit depot (equipment-specific) → Fig. I

Fit the belt hook (8) as shown.

Fit the bit depot (7) as shown.

8. Troubleshooting

8.1 Defective electronic safety shutdown (...LTX BL...)

Red continuous lighting of the LED lamp (14) signals a defective safety shutdown. Have the machine repaired. See chapter 10.

8.2 The machine's multifunctional monitoring system

 If the machine switches off automatically, the machine electronics have activated automatic protection mode. There will be a warning signal (beep). The beeping stops after a maximum of 30 seconds or when the trigger switch (15) is released.

 In spite of this protective function, overloading is still possible with certain applications and can result in damage to the machine.

Causes and remedies:

- Battery pack almost empty** → Fig. A, B (The electronics protect the battery pack against damage through total discharge).
If one LED (11) is flashing, the battery pack is almost flat. If necessary, press the button (10) and check the LED lamps (11) to see the charge level. If the battery pack is almost flat, it must be recharged.
- Long continuous overloading of the machine will activate the **temperature cut-out**.
Leave the machine or battery pack to cool.
Note: if the battery pack feels very warm, the pack will cool more quickly in an "AIR COOLED" charger.
Note: the machine will cool more quickly if you operate it at idling speed.
- Metabo **safety shutdown**: the machine has SHUT DOWN by itself. If the speed suddenly drops (for example, if the machine suddenly seizes or kickback occurs), the machine switches off. Switch off the machine at the trigger switch (15). Switch it on again and continue to work as normal. Try to prevent the machine from seizing.

8.3 Note:

The LED lamp (14) switches off automatically after a specific time.

9. Accessories

Use only original Metabo or CAS (Cordless Alliance System) battery packs and accessories.

Use only accessories that fulfil the requirements and specifications listed in these operating instructions.

Fit accessories securely. If the machine is operated in a holder: secure the machine well. Loss of control can cause personal injury.

See www.metabo.com or the catalogue for a complete range of accessories.

10. Repairs

 Repairs to electrical tools must only be carried out by qualified electricians!

Contact your local Metabo representative if you have Metabo power tools requiring repairs. For addresses see www.metabo.com.

You can download a list of spare parts from www.metabo.com.

11. Environmental Protection

Observe national regulations on environmentally compatible disposal and on the recycling of disused machines, packaging and accessories.

Battery packs may not be disposed of with regular waste. Return faulty or used battery packs to your Metabo dealer!

Do not allow battery packs to come into contact with water!

Discharge the battery pack in the power tool before disposal. Prevent the contacts from short-circuiting (e.g. by protecting them with adhesive tape).

12. Technical Data

→ Fig. J. We reserve the right to make technical improvements.

U = Voltage of battery pack
n₀ = No-load speed

Tightening torque for screwing:

M₁ = Soft screwing application (wood)

M₂ = Pulse torque

M₃ = Hard screwing applications (metal)

M₄ = Adjustable torque

Max. drill diameter:

D_{1 max} = in steel

D_{2 max} = in softwood

D_{3 max} = in masonry

s = Max. impact rate

m = Weight (with the smallest battery pack)

G = Spindle thread

D_{max} = Chuck clamping range

Permitted ambient temperature during operation:

-20 °C to 50 °C (limited performance with temperatures below 0 °C). Permitted ambient temperature for storage: 0 °C to 30 °C

The technical specifications quoted are subject to tolerances (in compliance with relevant valid standards).

 Emission values

These values make it possible to assess the emissions from the power tool and to compare different power tools. The actual load may be higher or lower depending on operating conditions, the condition of the power tool or the accessories used. Please allow for breaks and periods when the load is lower for assessment purposes. Arrange protective measures for the user, such as organisational measures based on the adjusted estimates.

Vibration total value (vector sum of three directions) determined in accordance with EN 62841:

a_{h, ID} = Vibration emission value (impact drilling in concrete)

a_{h, D} = Vibration emission value (Drilling in metal)

a_{h, S} = Vibration emission value (screwing without impact)

K_{h, ...} = Uncertainty (vibration)

Typical A-effective perceived sound levels:

L_{pa} = sound-pressure level

L_{WA} = Acoustic power level

K_{PA}, K_{WA} = Uncertainty (noise level)

During operation the noise level can exceed 80 dB(A).

 Wear ear protectors!