

metabo®

PROFESSIONAL POWER TOOL SOLUTIONS

KHEV 5-40 BL
KHEV 8-45 BL
KHEV 11-52 BL
MHEV 5 BL
MHEV 11 BL



de Originalbetriebsanleitung 5

en Original instructions 9

fr Notice originale 13

nl Oorspronkelijke gebruiksaanwijzing 18

it Istruzioni originali 22

es Manual original 26

pt Manual original 31

sv Bruksanvisning i original 35

fi Alkuperäiset ohjeet 39

no Original bruksanvisning 43

da Original brugsanvisning 47

pl Instrukcja oryginalna 51

el Πρωτότυπες οδηγίες λειτουργίας 55

hu Eredeti használati utasítás 60

ru Оригинальное руководство по эксплуатации 64

uk Оригінальна інструкція з експлуатації 69

KHEV...

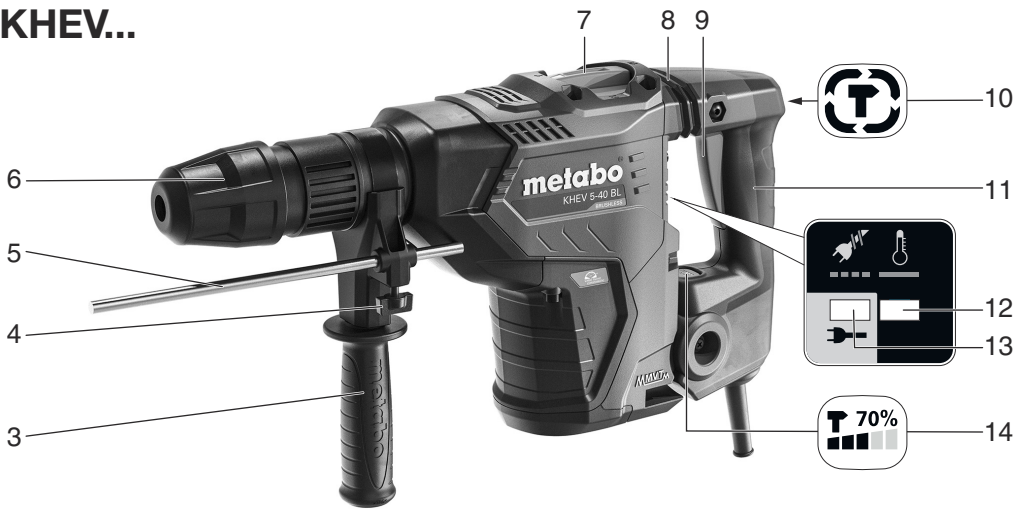

MHEV...

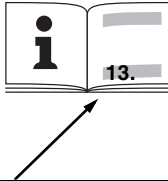

		KHEV 5-40 BL *1) Serial Number: 00765..	KHEV 8-45 BL *1) Serial Number: 00766..	KHEV 11-52 BL *1) Serial Number: 00767..	MHEV 5 BL *1) Serial Number: 00769..	MHEV 11 BL *1) Serial Number: 00770..
		SDS-max	SDS-max	SDS-max	SDS-max	SDS-max
P₁	W	1150	1500	1500	1500	1500
P₂	W	730	750	810	730	810
n₀	/min	0 - 350 0 - 500	0 - 210 0 - 300	0 - 200 0 - 270	-	-
D₁	mm (in)	40 (1 ⁹ / ₁₆)	45 (1 ²⁵ / ₃₂)	52 (2 ¹ / ₁₆)	-	-
D₂	mm (in)	105 (4 ¹ / ₈)	125 (4 ¹⁵ / ₁₆)	160 (6 ⁵ / ₁₆)	-	-
s_{max}	/min bpm	2900	2900	2400	2900	2100
W (EPTA 05/2009)	J	8,7	12,2	18,8	8,7	18,0
C	-	12	12	12	12	12
m	kg (lbs)	8,3 (18)	9,8 (22)	12,4 (27)	7,9 (17)	12,2 (27)
a_{h,HD}/K_{h,HD}	m/s²	10,5 (1,5)	11,8 (1,5)	13,5 (1,5)	-	-
a_{h,Cheq}/K_{h,Cheq}	m/s²	9,4 (1,5)	9,9 (1,5)	10,2 (1,5)	10,3 (1,5)	11,1 (1,5)
L_{pA}/K_{pA}	dB (A)	93 / 3	94 / 3	98 / 3	93 / 3	90 / 3
L_{WA}/K_{WA}	dB (A)	104 / 3	105 / 3	110 / 3	104 / 3	101 / 3
L_{pA(M)}	dB (A)	-	-	-	-	-
L_{WA(M)}	dB (A)	-	-	-	-	98,4
L_{WA(G)}	dB (A)	-	-	-	-	101,0



*2) KHEV...: 2014/30/EU, 2006/42/EC, 2011/65/EU
MHEV...: 2014/30/EU, 2006/42/EC, 2000/14/EC, 2011/65/EU

*3) EN 62841-1:2015, EN IEC 62841-2-6:2020+A11:2020, EN IEC 63000:2018

2022-12-19, Bernd Fleischmann
Direktor Produktentstehung & Qualität (Vice President Product Engineering & Quality)
*4) Metabowerke GmbH - Metabo-Allee 1 - 72622 Nuertingen, Germany

ppa. B.F.

(A)

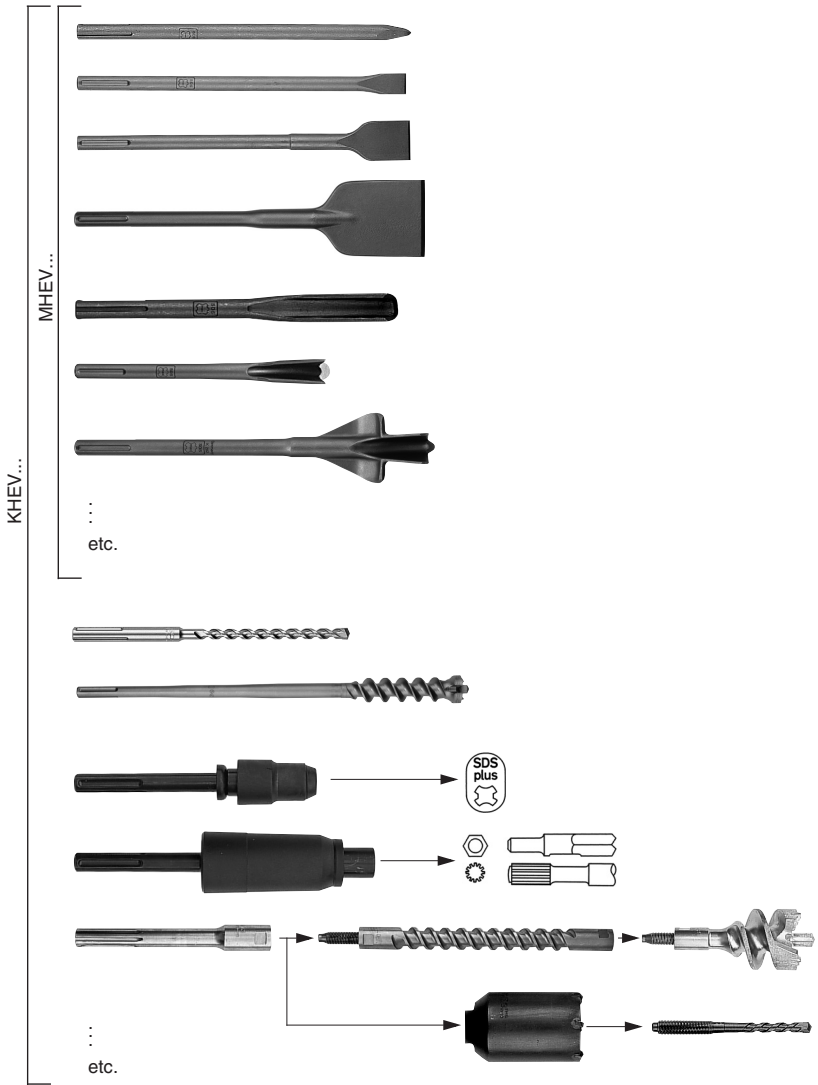

(B)



(C)



Original instructions

1. Declaration of Conformity

On our own responsibility, we hereby declare that this drilling and chisel hammer, identified by type and serial number *1), meets all relevant requirements of directives *2) and standards *3). Technical documents for *4) - see page 3.

MHEV...:2000/14/EC: Conformity assessment procedures in accordance with Annex VI (m < 15 kg). (Testing agency: Slovenian Institute of Quality and Metrology, Trzaska cesta 2, SI-1000 Ljubljana, Slovenia (Notified Body No.: 1304)).

For UK only:

UK We as manufacturer and authorized person to **CA** compile the technical file, see *4) on page 3, hereby declare under sole responsibility that these drilling and chisel hammer, identified by type and serial number *1) on page 3, fulfill all relevant provisions of following UK Regulations S.I. 2016/1091, S.I. 2008/1597, S.I. 2012/3032, only MHEV...: in addition S.I. 2001/1701 and Designated Standards EN 62841-1:2015, EN IEC 62841-2-6:2020+A11:2020, EN IEC 63000:2018.

2. Specified Conditions of Use

The combination hammer (KHEV...) is designed for hammer drilling and chiselling in concrete, bricks, stone and similar materials when used in combination with appropriate accessories.

The chisel hammer (MHEV...) is designed for chiselling in concrete, bricks, stone and similar materials when used in combination with appropriate accessories.

The user bears sole responsibility for any damage caused by inappropriate use.

Generally accepted accident prevention regulations and the enclosed safety information must be observed.

3. General Safety Information



For your own protection and for the protection of your power tool, pay attention to all parts of the text that are marked with this symbol!



WARNING – Read the operating instructions to reduce the risk of injury.



WARNING – Read all safety warnings, instructions, illustrations and specifications provided with this power tool. Failure to follow all instructions listed below may result in electric shock, fire and/or serious injury.

Save all warnings and instructions for future reference. Always include these documents when passing on your power tool.

4. Special Safety Instructions

4.1 Safety instructions for all operations

a) Wear ear protectors. Exposure to noise can cause hearing loss.

b) Use auxiliary handle(s), if supplied with the tool. Loss of control can cause personal injury.

c) Hold the power tool by insulated gripping surfaces, when performing an operation where the cutting accessory or fasteners may contact hidden wiring or its own cord. Cutting accessory contacting a "live" wire may make exposed metal parts of the power tool "live" and could give the operator an electric shock.

4.2 Safety instructions when using long drill bits with rotary hammers

a) Always start drilling at low speed and with the bit tip in contact with the workpiece. At higher speeds, the bit is likely to bend if allowed to rotate freely without contacting the workpiece, resulting in personal injury.

b) Apply pressure only in direct line with the bit and do not apply excessive pressure. Bits can bend, causing breakage or loss of control, resulting in personal injury.

4.3 Further Safety instructions

Pull the plug out of the socket before making any adjustments, changing tools, carrying out maintenance or cleaning.

Always work with the additional handle correctly installed.

Always hold the machine with both hands on the intended handles, take a secure stance and concentrate on the work.

Wear personal protective equipment and always wear safety glasses. Protective equipment such as dust mask, non-skid safety shoes, protective gloves, hard hat, or hearing protection used for appropriate conditions will reduce personal injuries.

Ensure that the place where you wish to work is free of **power cables, gas lines or water pipes** (e.g. check using a metal detector).

Work only with a correctly fitted tool. Pull on the tool to check that it is correctly seated. (It must be possible to move the tool a few centimetres in an axial direction.)

When working above ground level, ensure that the area below you is clear.

Never touch the tool or parts near the tool directly after work because they may be extremely hot and can cause burns to the skin,

Always position the power cable so that it leads away from the back of the machine.

A damaged or cracked additional handle must be replaced. Never operate a machine with a defective additional handle.

Secure the workpiece to prevent slipping or rotation (e.g. by securing with screw clamps).

Reducing dust exposure:

 **WARNING** - Some dust created by power sanding, sawing, grinding, drilling, and other construction activities contains chemicals known to cause cancer, birth defects or other reproductive harm. Some examples of these chemicals are:

- Lead from lead-based paints,
- Crystalline silica from bricks and cement and other masonry products, and
- Arsenic and chromium from chemically treated lumber.

Your risk from these exposures varies, depending on how often you do this type of work. To reduce your exposure to these chemicals: work in a well-ventilated area, and work with approved safety equipment, such as those dust masks that are specially designed to filter out microscopic particles.

This also applies to dust from other materials such as some timber types (like oak or beech dust), metals, asbestos. Other known diseases are e.g. allergic reactions, respiratory diseases. Do not let dust enter the body.

Observe the relevant guidelines and national regulations for your material, staff, application and place of application (e.g. occupational health and safety regulations, disposal).

Collect the particles generated at the source, avoid deposits in the surrounding area.

Use suitable accessories for special work. In this way, fewer particles enter the environment in an uncontrolled manner.

Use a suitable extraction unit.

Reduce dust exposure with the following measures:

- do not direct the escaping particles and the exhaust air stream towards yourself or nearby persons or towards dust deposits,
- use an extraction unit and/or air purifiers,
- ensure good ventilation of the workplace and keep it clean using a vacuum cleaner. Sweeping or blowing stirs up dust.
- Vacuum or wash protective clothing. Do not blow, beat or brush protective gear.

5. Overview

See page 2.

- 1 Clamping knob *
- 2 Bow handle (additional handle) *
- 3 Additional handle *
- 4 Wing screw (for adjusting the depth stop) *
- 5 Depth stop *
- 6 Tool lock
- 7 Knob
- 8 Metabo VibraTech (MVT): integrated damping system
- 9 Trigger
- 10 Button for continuous operation (only in chisel operating mode)
- 11 Handle
- 12 Electronic signal indicator

- 13 Operating indicator (light signal if mains power is connected)
- 14 Button for reduced impact force (for working in soft material)

* model-dependent, equipment-dependent

6. Initial Operation

 Before commissioning, check that the rated mains voltage and mains frequency stated on the type plate match your power supply.

 Always install a universal current sensitive ground fault circuit interruptor (type B RCD) with a maximum trip current of 30 mA upstream.

Use only extension cables with a minimum cross-section of 1.5 mm². Extension cables must correspond to the power consumption of the machine (cf Technical Specifications). If a cable roller is used, always roll up the cable completely.

6.1 Assembly of the bow handle or additional handle

 For safety reasons, always use the bow handle (2) or additional handle (3) supplied.

MHEV...:

Release the clamping ring by turning the clamping knob (1) anticlockwise. Adjust the bow handle (2) to the required position and angle. Tighten the clamping knob firmly.

KHEV...:

Open the clamping ring by turning the additional handle (3) anticlockwise. Secure the additional handle at the required angle. Tighten the additional handle.

7. Use

7.1 Depth Stop Setting
(Only for KHEV 5-40 BL)

Release the wing (4) screw. Set the depth stop (5) to the required drilling depth. Retighten the wing screw (4).

7.2 Positioning, removing tool

 Before inserting, clean tool shank and apply supplied special grease (accessories: Order no. 6.31800)! Use only SDS-max tools.

Positioning tool:

Turn tool and insert until it engages. The tool is automatically locked.

 Pull on the tool to check that it is correctly seated. (It must be possible to move the tool a few centimetres in an axial direction.)

Remove the tool:

Pull the tool lock (6) backwards in direction indicated by arrow (a) and remove tool (b).

7.3 Setting operating mode and chisel position



Avoid levering with the machine when a chisel is fitted.



Do not activate the switch button (7) until the motor has completely stopped.

Turn the switch button (7) to select the desired operating mode.



Impact drilling (only for KHEV...)



Chiselling



Setting which enables the chisel to be rotated to the desired position.

Setting the position of the chisel: The chisel can be locked in different positions.

- Insert the chisel.
- Turn the knob (7) to the interim position **N**.
- Turn the chisel to the required position.
- Turn the switch button (7) to position **T**.
- Turn the chisel until it engages.



When a chisel is fitted, only operate the machine in the chiselling operating mode **T**.

7.4 Setting impact force

Press the button (14) to change the impact force (and the speed) (but not while the motor is running).

Button (14) **illuminated:** reduced impact force, reduced speed (**approx. 70%**)

Button (14) **not illuminated:** maximum impact force, high speed (**100%**)

The correct setting is found by trial and error.

Example: if work is being completed on soft, brittle material or if you want to keep breakage to a low level, work at “reduced impact force”.

Use the “maximum impact force” setting for working with harder materials.

7.5 Switching on and off

Torque setting:

Press the trigger switch (9) to switch on the machine.

To switch off release the trigger switch (9).

Continuous operation (only in chiselling mode **T**):

The machine can be switched to continuous operation (only in chiselling mode **T**) by pressing the (10) button. ((10) button illuminated.)

To switch off, press the (10) button once again. ((10) button not illuminated.)



In continuous operation, the machine continues running if it is forced out of your hands. Therefore, always hold the machine with both hands using the handles provided, stand securely and concentrate.

7.6 Metabo VibraTech (MVT)

For reduced vibrations and less stress on the hands.

Always apply a moderate amount of pressure to the handle when pushing down the machine and do not force. Vibrations are reduced most effectively at the central position (8).

8. Cleaning, Maintenance

The power tool should be cleaned regularly, often and thoroughly through all air vents using a vacuum cleaner or by blowing in dry air. Prior to this operation, separate the power tool from the power source and wear protective glasses and dust mask.

9. Troubleshooting

Elektronic signal indicator (12)



Flashing - restart protection

When power is restored after a power failure, ---- the machine - which is still switched on - will not start for safety reasons. Switch machine on and off again.



Continuously illuminated - overload

If the machine is overloaded for a long period of time, the power intake is limited to avoid further excessive heating of the motor.

Allow the machine to run at idle speed until it has cooled off and the electronic signal indicator goes out.

10. Accessories

Use only genuine Metabo accessories.

Use only accessories that fulfil the requirements and specifications listed in these operating instructions.

See page 4.

- A Extensive drill bit and chisel assortment for a wide range of applications.
- B Special grease (for lubricating the tool shanks)
- C Dust extraction system

For a complete range of accessories, see www.metabo.com or the catalogue.

11. Repairs



Repairs to electrical tools must **ONLY** be carried out by qualified electricians!

A defective mains cable must only be replaced with a special, original mains cable from metabo, which is available only from the Metabo service.

The connection cable must only be replaced by Metabo or an authorised customer service workshop.

Contact your local Metabo representative if you have Metabo power tools requiring repairs. See www.metabo.com for addresses.

You can download a list of spare parts from www.metabo.com.

12. Environmental Protection

Observe national regulations on environmentally compatible disposal and on the recycling of disused machines, packaging and accessories.

Packaging materials must be disposed of according to their labelling in accordance with municipal guidelines. Further information can be found at www.metabo.com in the "Service" section.

Packaging materials must be disposed of according to their labelling in accordance with municipal guidelines. Further information can be found at www.metabo.com in the "Service" section.



Only for EU countries: never dispose of power tools in your household waste! Used power tools must be collected separately and handed in for environmentally compatible recycling in accordance with European Directive 2012/19/EU on waste electrical and electronic equipment and its implementation in national legal systems.

13. Technical Specifications

Explanatory notes on the specifications on page 3. Changes due to technological progress reserved.

- P_1 = Rated input power
- P_2 = Power output
- n_0 = No-load speed
- D_1 = Max. drilling diameter in concrete with impact masonry bits
- D_2 = Max. drilling diameter in concrete with impact core cutters
- s_{max} = Maximum impact rate
- W = Single impact force
- C = Number of chisel positions
- m = Weight without mains cable

Measured values determined in conformity with EN 62841.

- Machine in protection class II
- ~ AC power

The technical specifications quoted are subject to tolerances (in compliance with relevant valid standards).



Emission values

These values make it possible to assess the emissions from the power tool and to compare different power tools. The actual load may be higher or lower depending on operating conditions, the condition of the power tool or the accessories used. Please allow for breaks and periods when the load is lower for assessment purposes. Arrange protective measures for the user, such as organisational measures based on the adjusted estimates.

Total vibration value (vector sum of three directions) determined in accordance with EN 62841:

- $a_{h, HD}$ = Vibration emission value (hammer drilling into concrete)
- $a_{h, Cheq}$ = Vibration emission value (chiselling)
- $K_{h, HD/Cheq}$ = Uncertainty (vibration)

Typical A-effective perceived sound levels:

- L_{pa} = Sound-pressure level
- L_{WA} = Acoustic power level
- K_{pA}, K_{WA} = Uncertainty (noise level)
- $L_{pA(M)}$ = measured noise level according to 2000/14/EG at the user's ear
- $L_{WA(M)}$ = Measured acoustic power level as per 2000/14/EG
- $L_{WA(G)}$ = Guaranteed acoustic power level as per 2000/14/EC



During operation the noise level can exceed 80 dB(A).



Wear ear protectors!