

KS 66 FS

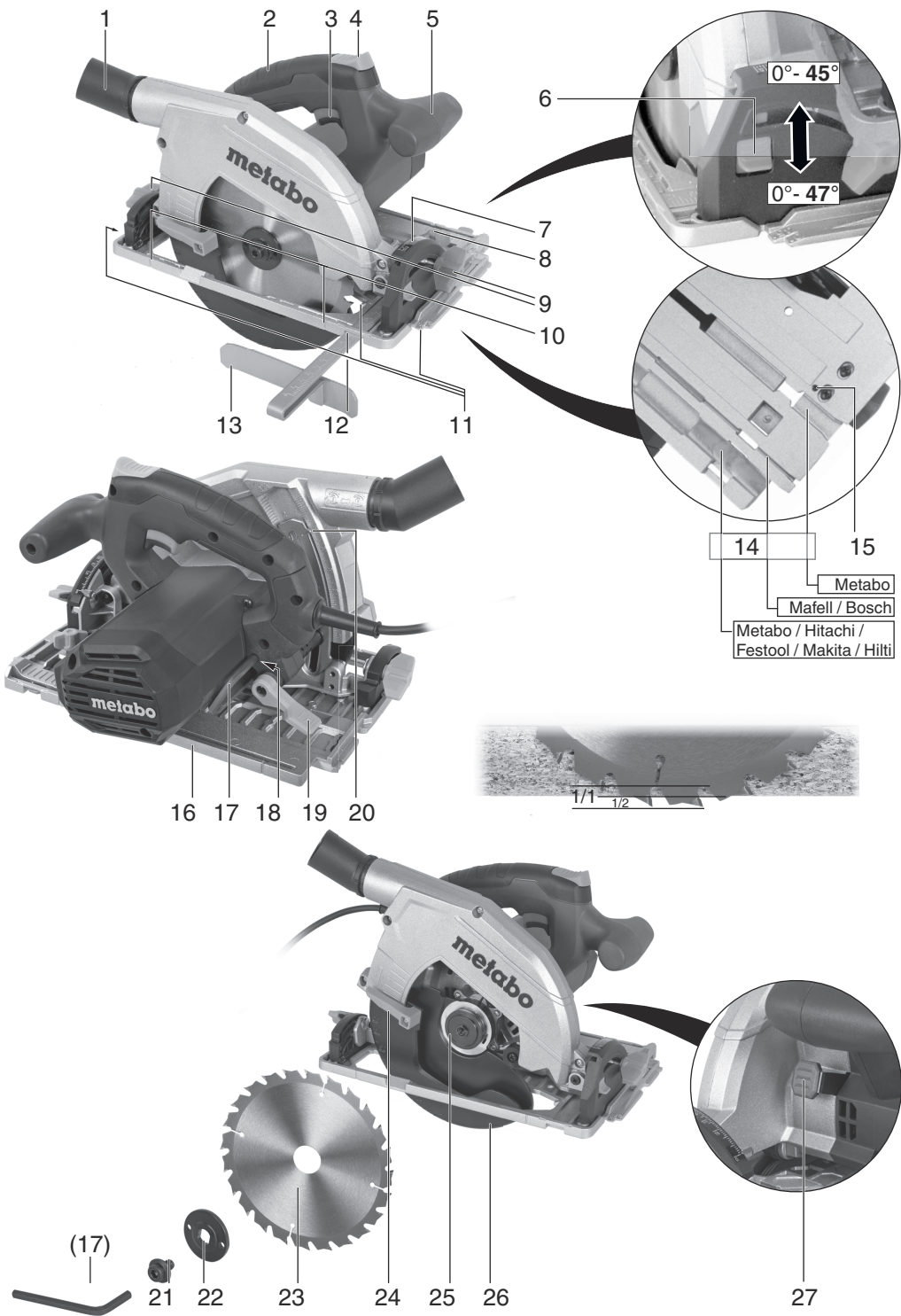

de	Originalbetriebsanleitung	4	fi	Alkuperäiskäyttöohje	50
en	Original instructions	10	no	Original bruksanvisning	55
fr	Instructions d'utilisation originales	15	da	Original brugsvejledning	60
nl	Oorspronkelijke gebruiksaanwijzing	21	pl	Instrukcja oryginalna	65
it	Istruzioni originali	27	el	Πρωτότυπο οδηγιών λειτουργίας	71
es	Manual de instrucciones original	33	hu	Eredeti használati utasítás	77
pt	Manual original	39	ru	Оригинальное руководство по эксплуатации	82
sv	Bruksanvisning i original	45	uk	Оригінальна інструкція з експлуатації	89

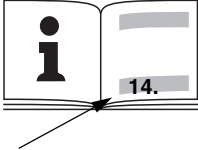

		<h2>KS 66 FS</h2> <p>*1) Serial Number: 01066..</p>
P ₁	W	1500
P ₂	W	840
n ₀	min ⁻¹ (rpm)	5000
n ₁	min ⁻¹ (rpm)	3800
T _{90°}	mm (in)	66 (2 ¹⁹ / ₃₂)
T _{45°}	mm (in)	47 (1 ²⁷ / ₃₂)
A	°	0-47
Ø	mm (in)	184 - 190 (7 ¹ / ₄ - 7 ¹ / ₂)
d	mm (in)	30 / 15,88 (1 ³ / ₁₆ / ⁵ / ₈)
a	mm (in)	1,6 (0.063)
b	mm (in)	2,2 (0.087)
m	kg (lbs)	4,9 (10.8)
a _{h,D} /K _{h,D}	m/s ²	2,5 / 1,5
L _{pA} / K _{pA}	dB (A)	95 / 3
L _{WA} / K _{WA}	dB (A)	106 / 3

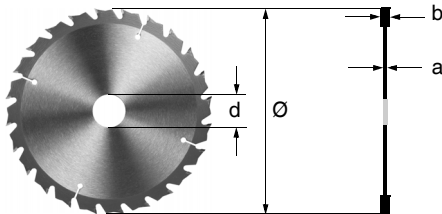

 *2) 2014/30/EU, 2006/42/EC, 2011/65/EU
 *3) EN 62841-1:2015, EN 62841-2-5:2014, EN IEC 63000:2018

2021-09-14, Bernd Fleischmann
 Direktor Produktentstehung & Qualität (Vice President Product Engineering & Quality)
 *4) Metabowerke GmbH - Metabo-Allee 1 - 72622 Nuertingen, Germany

ppa. B.F.

Original instructions

1. Declaration of Conformity

We declare and accept sole responsibility for ensuring: these circular saws identified by their type and serial number *1) conform to all relevant provisions of the directives *2) and standards *3). Technical documents for *4) - see page 3.

For UK only:

UK We as manufacturer and authorized person to **CA** compile the technical file, see *4) on page 3, hereby declare under sole responsibility that these cordless hand-held circular saws, identified by type and serial number *1) on page 3, fulfill all relevant provisions of following UK Regulations S.I. 2016/1091, S.I. 2008/1597, S.I. 2012/3032 and Designated Standards EN 62841-1:2015, EN 62841-2-5:2014, EN IEC 63000:2018

2. Specified Conditions of Use

This machine is suitable for sawing wood, plastics and other similar materials.

The machine is not designed for plunge cuts.

KS 66 FS is suited for working with Metabo guide rails and the Metabo mitre rail system.

The user bears sole responsibility for any damage caused by inappropriate use.

Generally accepted accident prevention regulations and the enclosed safety information must be observed.

3. General Safety Information



For your own protection and for the protection of your power tool, pay attention to all parts of the text that are marked with this symbol!



WARNING – Read the operating instructions to reduce the risk of injury.



WARNING – Read all safety warnings, instructions, illustrations and specifications provided with this power tool. Failure to follow all instructions listed below may result in electric shock, fire and/or serious injury.

Keep all safety instructions and information for future reference.

Always include these documents when passing on your power tool.

4. Special Safety Instructions

4.1 Sawing procedure



a) **DANGER: Keep hands away from cutting area and the blade. Keep your second hand on auxiliary handle, or motor housing.** If both hands are holding the saw, they cannot be cut by the blade.

b) **Do not reach underneath the workpiece.** The guard cannot protect you from the blade below the workpiece.

c) **Adjust the cutting depth to the thickness of the workpiece.** Less than a full tooth of the blade teeth should be visible below the workpiece.

d) **Never hold the workpiece in your hands or across your leg while cutting. Secure the workpiece to a stable platform.** It is important to support the work properly to minimise body exposure, blade binding, or loss of control.

e) **Hold the power tool by the insulated gripping surfaces when performing an operation where the cutting accessory may contact hidden wiring or its own cord.** Contact with a "live" wire will also make exposed metal parts of the power tool "live" and could give the operator an electric shock.

f) **When ripping, always use a rip fence or straight edge guide.** This improves the accuracy of cut and reduces the chance of blade binding.

g) **Always use blades with correct size and shape (diamond versus round) of arbour holes.** Blades that do not match the mounting hardware of the saw will run off-centre, causing loss of control.

h) **Never use damaged or incorrect blade washers or bolt.** The blade washers and bolt were specially designed for your saw, for optimum performance and safety of operation.

4.2 Kickback causes and related warnings

- kickback is a sudden reaction to a pinched, jammed or misaligned saw blade, causing an uncontrolled saw to lift up and out of the workpiece toward the operator;

- When the blade is pinched or jammed tightly by the kerf closing down, the blade stalls and the motor reaction drives the unit rapidly back toward the operator.

- If the blade becomes twisted or misaligned in the cut, the teeth at the back edge of the blade can dig into the top surface of the wood causing the blade to climb out of the kerf and jump back toward the operator.

Kickback is the result of saw misuse and/or incorrect operating procedures or conditions and can be avoided by taking proper precautions as given below.

a) **Maintain a firm grip with both hands on the saw and position your arms to resist kickback forces. Position your body to either side of the blade, but not in line with the blade.** Kickback could cause the saw to jump backwards, but kickback forces can be controlled by the operator, if proper precautions are taken.

b) **When blade is binding, or when interrupting a cut for any reason, release the trigger and hold the saw motionless in the material until the blade comes to a complete stop. Never attempt to remove the saw from the work or pull the saw backward while the blade is in motion or kickback may occur.** Investigate and

take corrective actions to eliminate the cause of blade binding.

c) **When restarting a saw in the workpiece, centre the saw blade in the kerf so that the saw teeth are not engaged into the material.** If a saw blade binds, it may walk up or kickback from the workpiece as the saw is restarted.

d) **Support large panels to minimise the risk of blade pinching and kickback.** Large panels tend to sag under their own weight. Supports must be placed under the panel on both sides, near the line of cut and near the edge of the panel.

e) **Do not use dull or damaged blades.** Unsharpened or improperly set blades produce narrow kerf causing excessive friction, blade binding and kickback.

f) **Blade depth and bevel adjusting locking levers must be tight and secure before making the cut.** If blade adjustment shifts while cutting, it may cause binding and kickback.

g) **Use extra caution when sawing into existing walls or other blind areas.** The protruding blade may cut objects that can cause kickback.

4.3 Lower guard function

a) **Check the lower guard for proper closing before each use. Do not operate the saw if the lower guard does not move freely and close instantly. Never clamp or tie the lower guard into the open position.** If the saw is accidentally dropped, the lower guard may be bent. Raise the lower guard with the retracting handle (24) and make sure it moves freely and does not touch the blade or any other part, in all angles and depths of cut.

b) **Check the operation of the lower guard spring. If the guard and the spring are not operating properly, they must be serviced before use.** Lower guard may operate sluggishly due to damaged parts, gummy deposits, or a build-up of debris.

c) **The lower guard may be retracted manually only for special cuts such as "plunge cuts" and "compound cuts". Raise the lower guard by the retracting handle (24) and as soon as the blade enters the material, the lower guard must be released.** For all other sawing, the lower guard should operate automatically.

d) **Always observe that the lower guard is covering the blade before placing the saw down on bench or floor.** An unprotected, coasting blade will cause the saw to walk backwards, cutting whatever is in its path. Be aware of the time it takes for the blade to stop after switch is released.

4.4 Additional Safety Instructions

Do not use sanding discs.

Pull the plug out of the plug socket before any adjustments or servicing are performed.

Keep hands away from the rotating tool! Remove chips and similar material only when the machine is at a standstill.



Wear a suitable dust protection mask.



Wear ear protectors.



Wear protective goggles.

Press the spindle locking button only when the motor is at a standstill.

Do not reduce the speed of the saw blade by pressing on the sides.

The movable guard must not be clamped in the pulled-back position for sawing.

The movable guard must move freely, automatically, easily and exactly back into its end position.

When sawing materials that generate large quantities of dust, the machine must be cleaned regularly. Make sure that the safety appliances, e.g. the movable guard, are in perfect working order.

Materials that generate dusts or vapours that may be harmful to health (e.g. asbestos) must not be processed.

Check the workpiece for foreign bodies. When working, always make sure that no nails or other similar materials are being sawed into.

If the saw blade blocks, turn the motor off immediately.

Do not try to saw extremely small workpieces.

During machining, the workpiece must be firmly supported and secured against moving.

Use a saw blade that is suitable for the material being sawn.

Clean gummy or glue-contaminated saw blades. Contaminated saw blades cause increased friction, jamming of the saw blade and increase the risk of back-kicks.

Avoid overheating of the saw tooth tips. Avoid melting of the material when sawing plastic.

Use a saw blade that is suitable for the material being sawn.

Reducing dust exposure:



WARNING - Some dust created by power sanding, sawing, grinding, drilling, and other construction activities contains chemicals known to cause cancer, birth defects or other reproductive harm. Some examples of these chemicals are:

- Lead from lead-based paints,
- Crystalline silica from bricks and cement and other masonry products, and
- Arsenic and chromium from chemically treated lumber.

Your risk from these exposures varies, depending on how often you do this type of work. To reduce your exposure to these chemicals: work in a well-ventilated area, and work with approved safety equipment, such as those dust masks that are specially designed to filter out microscopic particles.

This also applies to dust from other materials such as some timber types (like oak or beech dust), metals, asbestos. Other known diseases are e.g. allergic reactions, respiratory diseases. Do not let dust enter the body.

Observe the relevant guidelines and national regulations for your material, staff, application and place of application (e.g. occupational health and safety regulations, disposal).

Collect the particles generated at the source, avoid deposits in the surrounding area.

Use suitable accessories for special work. In this way, fewer particles enter the environment in an uncontrolled manner.

Use a suitable extraction unit.

Reduce dust exposure with the following measures:

- do not direct the escaping particles and the exhaust air stream towards yourself or nearby persons or towards dust deposits,
- use an extraction unit and/or air purifiers,
- ensure good ventilation of the workplace and keep it clean using a vacuum cleaner. Sweeping or blowing stirs up dust.
- Vacuum or wash protective clothing. Do not blow, beat or brush protective gear.

5. Overview

See page 2.

- 1 Connector (extraction connection piece / chip ejection)
- 2 Handle
- 3 Trigger
- 4 Locking button
- 5 Side handle
- 6 Undercut limit stop (increases the max. diagonal cut angle from 45° to 47°)
- 7 Scale (diagonal cut angle)
- 8 Locking screw (parallel guide)
- 9 2 Locking screws (diagonal cuts)
- 10 Marking (saw blade outer diameter)
- 11 Cutting indicator
- 12 Parallel stop
- 13 Marking (for reading off the scale on the parallel guide)
- 14 Guide grooves to place the machines on guide tracks from different manufacturers
- 15 Adjusting screw (adjust saw disc angle)
- 16 Guide plate
- 17 Hexagon wrench
- 18 Storage for hexagon wrench
- 19 Locking screw (depth of cut)
- 20 Scale (depth of cut)
- 21 Saw blade fixing screw
- 22 Outer saw blade flange
- 23 Saw blade
- 24 Lever (for swivelling back the movable guard)
- 25 Inner saw blade flange
- 26 Movable safety guard
- 27 Spindle locking button

6. Initial Operation, Setting

 Before commissioning, check that the rated mains voltage and mains frequency stated on the type plate match your power supply.

 Always install an RCD with a maximum trip current of 30 mA upstream.

 Pull the plug out of the plug socket before any adjustments or servicing are performed.

6.1 Setting cutting depth

Loosen the locking screw (19). Raise or lower the motor section against the guide plate (16). Read the depth of cut that has been set from the scale (20). Tighten the locking screw (19) again.

It is advisable to set the depth of cut in such a way that no more than half of each tooth on the saw blade juts out under the workpiece. See illustration on page 2.

Note: The clamping power of the locking screw (19) can be adjusted. Unscrew the screw on the lever to do this. Remove lever and mount offset anticlockwise. Secure with screw. Ensure that cutting depth adjustment moves freely when the lever is open.

6.2 Slanting saw blade for diagonal cuts

Loosen the locking screws (9). Tilt the motor section against the guide plate (16). Read the angle which has been set from the scale (7). Tighten the locking screws (9) again.

For a diagonal cut angle of 47°, push down the undercut limit stop (6).

6.3 Correcting the saw disc angle

If, at 0°, the saw blade is not at right angles to the guide plate: use the adjustment screw (15) to correct the saw blade angle.

6.4 Setting extraction nozzle / chip ejection

The nozzle (1) can be rotated to the desired position to extract or eject chips. To do this, push the nozzle in up to the stop, turn and pull out again. The nozzle can be locked in 45° increments so that it cannot turn.

Sawdust extraction

To extract the sawdust, connect a suitable extraction unit with suction hose to the machine.

7. Use

7.1 Switching on and off

Switching on: Push the locking button (4) forwards and hold, then actuate the trigger (3).

Switching off: Release the trigger switch (3).

7.2 Working Directions

Lay out the mains cable such that the cut can be executed without obstruction.

The marking (10) on the upper guide plate assists you in positioning the saw on the workpiece and

when sawing. In the case of maximum cutting depth, it marks approximately the outside diameter of the saw blade and thus the cutting edge.

 Do not switch the machine on or off while the saw blade is touching the workpiece.

 Let the saw blade reach its full speed before making a cut.

When the hand-held circular saw is added, the movable guard is swung backwards by the workpiece.

 When sawing, never remove the machine from the material with the saw blade turning. Allow the saw blade to come to a standstill.

 If the saw blade blocks, turn the machine off immediately.

Sawing along a straight line: the cutting indicator is used here (11). The left notch (marked 0°) indicates the direction of the cut if the saw blade is held vertically. The right notch (marked 45°) indicates the direction of the cut if the saw blade is held at 45°.

Sawing along a rail secured on the workpiece: In order to achieve an exact cutting edge, you can attach a rail to the workpiece and then guide the hand-held circular saw along this rail by means of the guide plate (16).

Sawing with parallel guide:

For cuts parallel to a straight edge. The parallel guide (12) can be inserted from either side into the support provided for it. Tighten the locking screw (8). It is best to calculate the exact cut width by making a test cut.

Sawing with guide rail:

For dead straight, tear-free cutting edges with millimetre precision. The anti-slip coating keeps the surface safe and protects the workpiece against scratches.

Saws with mitre rail system:

The machine is prepared for accommodation by the Metabo mitre rail system. This permits particularly comfortable mitre cuts of different angles.

8. Maintenance

Changing saw blades

 Pull the plug out of the plug socket before any adjustments or servicing are performed.

Press in the spindle locking button (27) and hold in place. Turn the saw spindle slowly with the hexagon wrench in the saw blade fixing screw (21) until the lock catches.

Unscrew the saw blade fixing screw (21) in a clockwise direction and remove the outer saw blade flange (22).

Pull back the movable safety guard (26) using the lever (24) and remove the saw blade (23).

The contact areas between the inner saw blade flange (25), the saw blade (23), the outer saw blade flange (22) and the saw blade fixing screw (21) must be clean.

 Ensure that the inner saw blade flange (25) is inserted in the right way: The inner saw blade flange (25) has 2 sides, diameter 30 mm and 5/8" (15.88 mm). Ensure a precise fit of saw blade mounting hole to the inner saw blade flange (25)! Incorrectly installed saw blades do not run smoothly and lead to loss of control.

Insert a new saw blade, Make sure the direction of rotation is correct. The direction of rotation is indicated by arrows on the saw blade and guard.

Put on the outer saw blade flange (22).

Tighten the saw blade fixing screw (21) using the (17) hexagon wrench.

 Use only sharp, undamaged saw blades. Do not use saw blades that are cracked or that have changed their shape.

 Do not use any saw blades made from high-alloy high-speed steel (HSS).

 Do not use any saw blades which do not conform to the specified rating. Use only saw blades with a diameter according to the markings on the saw.

 The saw blade must be suitable for the no-load speed.

 Use a saw blade that is suitable for the material being sawn.

 Use only genuine Metabo - saw blades. Saw blades intended for cutting wood or similar materials have to conform to EN 847-1.

9. Cleaning

Dust deposits must be regularly removed from the machine. This includes vacuum cleaning the ventilation louvres on the motor. Make sure that the safety appliances, e.g. the movable guard, are in perfect working order. The movable guard must move freely, automatically, easily and exactly back into its end position.

10. Troubleshooting

Switching on the machine briefly reduces the voltage. Unfavourable mains power conditions may have a detrimental effect on other machines. Power impedances less than 0.3 ohm should not cause malfunctions.

11. Accessories

Use only genuine Metabo accessories.

Use only accessories that fulfil the requirements and specifications listed in these operating instructions.

For the complete range of accessories, see www.metabo.com or the main catalogue.

12. Repairs

 Repairs to electrical tools must only be carried out by qualified electricians!

A defective mains cable must be replaced only with a special, original mains cable from Metabo available from the Metabo service.

Contact your local Metabo representative if you have Metabo power tools requiring repairs. For addresses see www.metabo.com.

You can download a list of spare parts from www.metabo.com.

$K_{h,D}$ = Uncertainty (vibration)

Typical A-effective perceived sound levels:

L_{pa} = Sound-pressure level

L_{WA} = Acoustic power level

K_{pA} , K_{WA} = Uncertainty

The noise level can exceed 80 dB(A) during operation.



Wear ear protectors!

13. Environmental Protection

Observe national regulations on environmentally compatible disposal and on the recycling of disused machines, packaging and accessories.



Only for EU countries: never dispose of power tools in your household waste!

According to European Directive 2012/19/EU on Waste from Electric and Electronic Equipment and implementation in national law, used power tools must be collected separately and recycled in an environmentally-friendly manner.

14. Technical Specifications

Explanatory notes on the specifications on page 3. Changes due to technological progress reserved.

P_1 = Rated input

P_2 = Power output

n_0 = No-load speed

n_1 = On-load speed

T_{max} = maximum depth of cut

T_{90° = max. depth of cut (90°)

T_{45° = max. depth of cut (45°)

A = adjustable angular cut angle

\emptyset = saw blade diameter

d = saw blade drill diameter

a = max. base body thickness of the saw blade

b = cutting width of the saw blade

m = weight

Measured values determined in conformity with EN 62841.

Machine in protection class II

~ AC Power

The technical specifications quoted are subject to tolerances (in compliance with relevant valid standards).



Emission values

These values make it possible to assess the emissions from the power tool and to compare different power tools. The actual load may be higher or lower depending on operating conditions, the condition of the power tool or the accessories used. Please allow for breaks and periods when the load is lower for assessment purposes. Arrange protective measures for the user, such as organisational measures based on the adjusted estimates.

Vibration total value (vector sum of three directions) determined in accordance with EN 62841:

$a_{h,D}$ = Vibration emission value
(Sawing chip board)