

## FSR 200 Intec

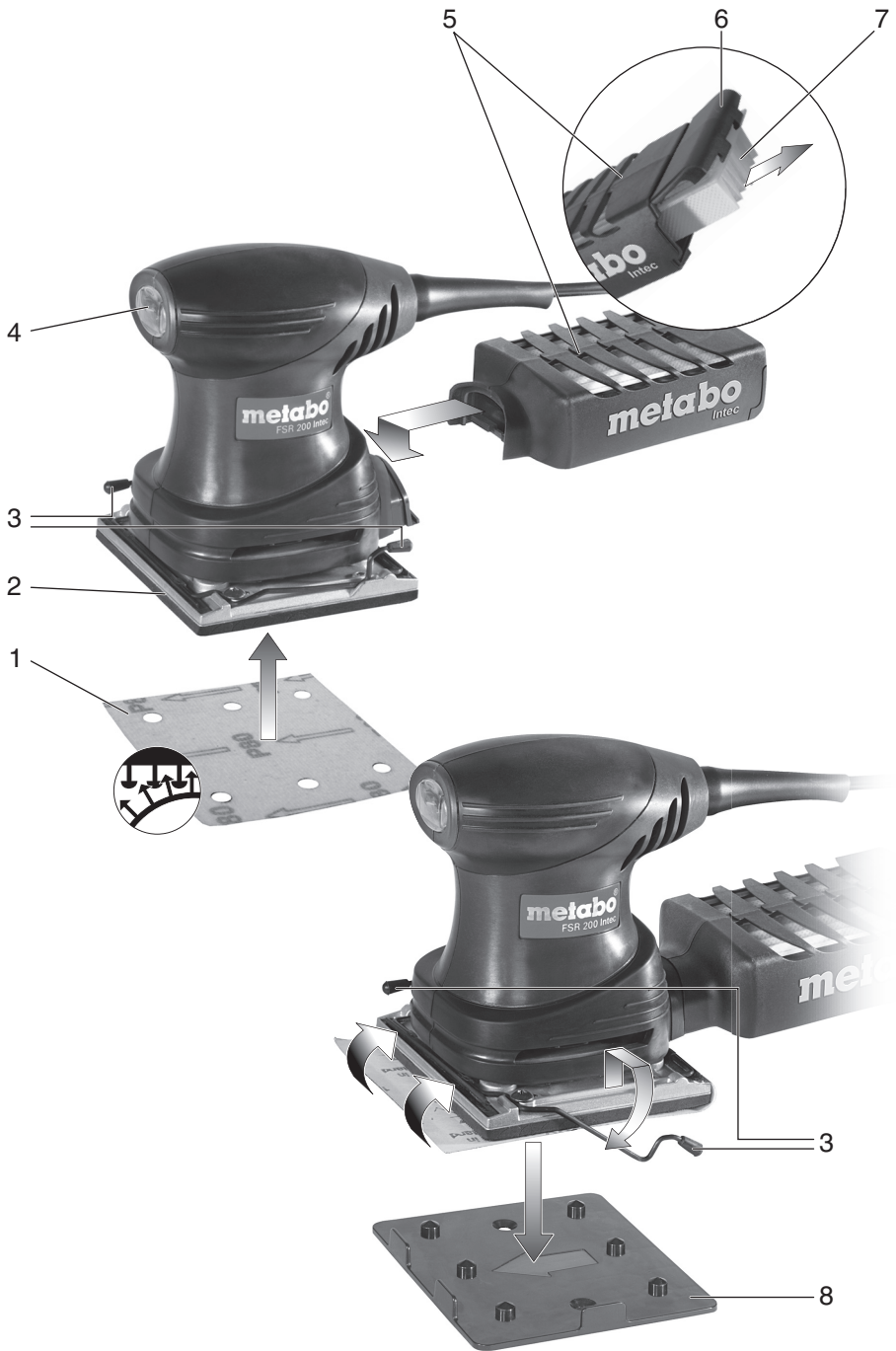

---

<b>de</b>	Originalbetriebsanleitung	5
<b>en</b>	Original instructions	8
<b>fr</b>	Notice originale	11
<b>nl</b>	Oorspronkelijke gebruiksaanwijzing	14
<b>it</b>	Istruzioni originali	17
<b>es</b>	Manual original	20
<b>pt</b>	Manual original	23
<b>sv</b>	Bruksanvisning i original	26
<b>fi</b>	Alkuperäiset ohjeet	29
<b>no</b>	Original bruksanvisning	32
<b>da</b>	Original brugsanvisning	35
<b>pl</b>	Instrukcja oryginalna	38
<b>el</b>	Πρωτότυπες οδηγίες χρήσης	41
<b>hu</b>	Eredeti használati utasítás	44
<b>ru</b>	Оригинальное руководство по эксплуатации	47

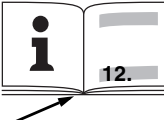

		<b>FSR 200 Intec</b> *1) Serial Number: 00066..
<b>A</b>	mm (in)	114 x 102 (3 1/2 x 4 )
<b>P<sub>1</sub></b>	W	200
<b>P<sub>2</sub></b>	W	80
<b>s<sub>0</sub></b>	min <sup>-1</sup> (opm)	26.000
<b>s<sub>1</sub></b>	min <sup>-1</sup> (opm)	22.000
<b>S</b>	mm (in)	1,4 ( 1/16)
<b>Intec</b>	-	✓
<b>m</b>	kg (lbs)	1,25 ( 2.76)
<b>a<sub>h</sub>,K<sub>h</sub></b>	m/s <sup>2</sup>	3 / 1,5
<b>L<sub>pA</sub>,K<sub>pA</sub></b>	dB(A)	76 / 3
<b>L<sub>WA</sub>,K<sub>WA</sub></b>	dB(A)	87 / 3

**CE** \*2) 2014/30/EU, 2006/42/EC, 2011/65/EU  
\*3) EN 62841:2015, EN 62841-2-4:2014, EN IEC 63000:2018

2021-06-17, Bernd Fleischmann *ppa. B.F.*  
Direktor Produktentstehung & Qualität (Vice President Product Engineering & Quality)  
\*4) Metabowerke GmbH - Metabo-Allee 1 - 72622 Nuertingen, Germany

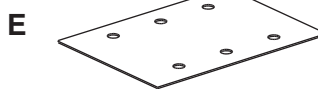
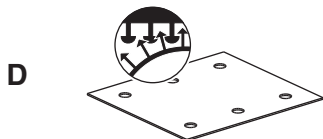
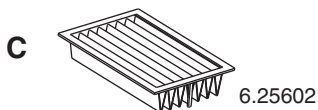
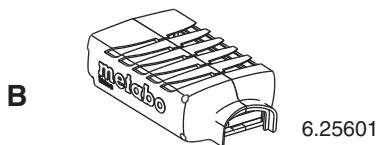
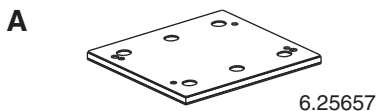

- 10 x P 40 .... 6.25619
- 10 x P 60 .... 6.25620
- 10 x P 80 .... 6.25621
- 10 x P 100 .... 6.25622
- 10 x P 120 .... 6.25623
- 10 x P 180 .... 6.25624
- 10 x P 240 .... 6.25625
- 10 x P 320 .... 6.25626
- 10 x P 400 .... 6.25627

- 10 x P 40 .... 6.25629
- 10 x P 60 .... 6.25630
- 10 x P 80 .... 6.25631
- 10 x P 100 .... 6.25632
- 10 x P 120 .... 6.25633
- 10 x P 180 .... 6.25634
- 10 x P 240 .... 6.25635
- 10 x P 320 .... 6.25636
- 10 x P 400 .... 6.25637

- 2 x P 40 +
- 2 x P 80 +
- 2 x P 120 +
- 2 x P 180 +
- 2 x P 240 .... 6.25628

- 2 x P 40 +
- 2 x P 80 +
- 2 x P 120 +
- 2 x P 180 +
- 2 x P 240 .... 6.25638

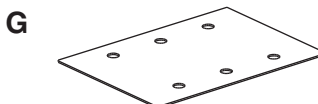
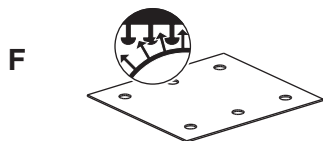

- 10 x P 40 .... 6.25639
- 10 x P 60 .... 6.25640
- 10 x P 80 .... 6.25641
- 10 x P 100 .... 6.25642
- 10 x P 120 .... 6.25643
- 10 x P 180 .... 6.25644
- 10 x P 240 .... 6.25645
- 10 x P 320 .... 6.25646

- 10 x P 40 .... 6.25648
- 10 x P 60 .... 6.25649
- 10 x P 80 .... 6.25650
- 10 x P 100 .... 6.25651
- 10 x P 120 .... 6.25652
- 10 x P 180 .... 6.25653
- 10 x P 240 .... 6.25654
- 10 x P 320 .... 6.25655

- 2 x P 40 +
- 2 x P 80 +
- 2 x P 120 +
- 2 x P 180 +
- 2 x P 240 .... 6.25647

- 2 x P 40 +
- 2 x P 80 +
- 2 x P 120 +
- 2 x P 180 +
- 2 x P 240 .... 6.25656



# Original instructions

## 1. Conformity Declaration

We, being solely responsible, hereby declare that these sanders, identified by type and serial number \*1), meet all relevant requirements of directives \*2) and standards \*3). Technical documents for \*4) - see page 3.

### For UK only:

**UK** We as manufacturer and authorized person to **CA** compile the technical file, see \*4) on page 3, hereby declare under sole responsibility that these random orbital sanders, identified by type and serial number \*1) on page 3, fulfill all relevant provisions of following UK Regulations S.I. 2016/1091, S.I. 2008/1597, S.I. 2012/3032 and Designated Standards EN 62841:2015, EN 62841-2-4:2014, EN IEC 63000:2018.

## 2. Specified Use

The machine is suitable for dry sanding of flat and elliptical surfaces, wood, plastics, non-ferrous metals, sheet metal and similar filled and painted surfaces.

The user bears sole responsibility for damage caused by improper use.

Generally accepted accident prevention regulations and the enclosed safety information must be observed.

## 3. General Safety Instructions



For your own protection and for the protection of your electrical tool, pay attention to all parts of the text that are marked with this symbol!



**WARNING** – Reading the operating instructions will reduce the risk of injury.



**WARNING** – Read all safety warnings, instructions, illustrations and specifications provided with this power tool. Failure to follow all instructions listed below may result in electric shock, fire and/or serious injury.

**Save all warnings and instructions for future reference.** Pass on your electrical tool only together with these documents.

## 4. Special Safety Instructions

Pull the plug out of the socket before making any adjustments, changing tools, carrying out maintenance or cleaning.

Secure the workpiece against slipping, e.g. with the help of clamping devices.

**Wear ear protectors when working for long periods of time.** High noise levels over a prolonged period of time may affect your hearing.

**Reducing dust exposure:**



Some of the dust created using this power tool may contain substances known to cause cancer, allergic reaction, respiratory disease, birth defects or other reproductive harm. Some examples of these substances are: lead (from lead-based paints), crystalline silica (from bricks cement, etc.), additives for wood treatment (chromate, wood preservative), some types of wood (like oak and beech dust), metals, asbestos.

The risk from exposure to such substances will depend on how long the user or nearby persons are being exposed.

Do not let particles enter the body.

To reduce exposure to these substances: work in a well ventilated area and wear protective equipment, such as dust masks that are specially designed to filter out microscopic particles.

Observe the relevant guidelines for your material, staff, application and place of application (e.g. occupational health and safety regulations, disposal).

Collect the generated particles at the source, avoid deposits in the surrounding area.

Use only suitable accessories. In this way, fewer particles enter the environment in an uncontrolled manner.

Use a suitable extraction unit.

Reduce dust exposure with the following measures:

- Do not direct the escaping particles and the exhaust air stream at yourself or nearby persons or on dust deposits.
- Use an extraction unit and/or air purifiers.
- Ensure good ventilation of the workplace and keep it clean using a vacuum cleaner. Sweeping or blowing stirs up dust.

Vacuum or wash protective clothing. Do not blow, beat or brush.

## 5. Overview

See page 2.

- 1 Sanding disc
- 2 Sanding plate
- 3 Clamping lever
- 4 On/off switch
- 5 Dust collection box \*
- 6 Cleaning flap
- 7 Fluted filter
- 8 Hole punch

\* depending on model

## 6. Commissioning



Before plugging in, check to see that the rated mains voltage and mains frequency, as stated on the rating label, match your power supply.



Always install an RCD with a maximum trip current of 30 mA upstream.

## 6.1 Installation of sanding disc

### Sanding sheet with velcro-type fastening

Simple attachment and removal thanks to the velcro-type fastening.

Simply press on the sanding disc such that the holes in the sanding disc (1) are aligned with the support plate (2).

### Sanding sheet without velcro-type fastening

- Swivel clamping lever (3) downwards as shown in illustration on page 2. This opens the clamp rail.
- Slide sanding disc under clamp rail.
- Clamp sanding disc on other side with clamping lever (3).
- Pull sanding disc tightly over the sanding plate and clamp to the other side with clamping lever (3).

### Hole punch

In non-perforated sanding discs, the hole punch can be used to punch your own holes for dust extraction.

- Install sanding disc on sander.
- Place sander on hole punch (8) as shown in the illustration on page 2 and press downwards.

## 7. Use

### 7.1 Switching On and Off

#### Switching on:

Move switch (4) to "I" position.

#### Switching off:

Move switch (4) to "O" position.

### 7.2 Dust Extraction

To optimise the dust extraction performance, fit the sanding disc such that the holes on the sanding disc (1) and sanding plate (2) are aligned.

#### Integrated extraction system:

Install the dust collection box (5) (see illustration, page 2). To optimise the extraction performance, empty the dust collection box (5) in good time and clean the filter (7).

#### External extraction system:

Fit dust extraction nozzle (see chapter on Accessories). Connect a suitable extraction device. Use a suction hose with a 35 mm connector diameter. See Accessories section.

**Note:** When sanding abrasive material (e.g. plaster, etc.) we recommend connecting a suitable dust extractor.

## 8. Cleaning, Maintenance

### Empty dust collection box (5).

- Open cleaning flap (6).
- Empty dust collection box (5).
- Remove fluted filter (7) and knock off dust stuck to filter or remove with brush.
- When inserting, ensure that the fluted filter (7) is inserted in the lateral guides.

**Clean the machine regularly.** This includes vacuum cleaning the ventilation louvres on the motor.

Replacing worn sanding plate (2)

- Remove fixing screws (on lower side of sanding plate).
- Take off sanding plate.
- For sanding plate (as replacement), refer to the Accessories chapter.
- Mount sanding plate.
- Refit fixing screws (on lower side of sanding plate) and tighten.

## 9. Accessories

Use only genuine Metabo accessories.

See page 4.

Use only accessories which fulfil the requirements and specifications listed in these operating instructions.

- A Sanding plate (as replacement)
- B Dust collection box with fluted filter for multiple cleaning (as replacement)
- C Fluted filter (as replacement)
- D Perforated adhesive sanding discs for wood and metal, 115 x 103 mm
- E Perforated adhesive sanding discs for wood and metal, for clamping 115 x 140 mm
- F Perforated adhesive sanding discs for paint, lacquer, spattle, 115 x 103 mm
- G Perforated sanding discs for paint, lacquer, spattle, for clamping, 115 x 140 mm
- H Dust extraction connection
  - I Metabo universal vacuum cleaner

For complete range of accessories, see [www.metabo.com](http://www.metabo.com) or the main catalogue.

## 10. Repairs



Repairs to electrical tools must be carried out by qualified electricians ONLY!

A defective mains cable must only be replaced with a special, original mains cable from metabo, which is available only from the Metabo service.

If you have Metabo electrical tools that require repairs, please contact your Metabo service centre. For addresses see [www.metabo.com](http://www.metabo.com).

You can download spare parts lists from [www.metabo.com](http://www.metabo.com).

## 11. Environmental Protection

Observe national regulations on environmentally compatible disposal and on the recycling of disused machines, packaging and accessories.



Only for EU countries: Never dispose of power tools in your household waste! In accordance with European Guideline 2012/19/EU on used electronic and electric equipment and its implementation in national legal systems, used power tools must be collected separately and handed in for environmentally compatible recycling.

## 12. Technical Specifications

Explanatory notes on the specifications on page 3.

Changes due to technological progress reserved.

D	= Dimensions of sanding plate
$P_1$	= Nominal power input
$P_2$	= Power output
$s_0$	= orbital frequency at no load
$s_1$	= orbital frequency at nominal load
S	= Oscillating circuit diameter
Intec	= Dust collection box
m	= Weight without mains cable

Measured values determined in conformity with EN 62841.

Machine in protection class II

~ Alternating current

The technical specifications quoted are subject to tolerances (in compliance with the relevant valid standards).



### Emission values

These values make it possible to assess the emissions from the power tool and to compare different power tools. Depending on the operating conditions, the condition of the power tool or the accessories, the actual load may be higher or lower. For assessment purposes, please allow for breaks and periods when the load is lower. Based on the adjusted estimates, arrange protective measures for the user e.g. organisational measures.

Vibration total value (vector sum of three directions) determined in accordance with EN 62841:

$a_h$  = Vibration emission value  
(Surface sanding)

$K_h$  = Unsafe (vibration)

Typical A-effective perceived sound levels:

$L_{pA}$  = Sound pressure level

$L_{WA}$  = Acoustic power level

$K_{pA}$ ,  $K_{WA}$  = Uncertainty

During operation the noise level can exceed 80 dB(A).



**Wear ear protectors!**