

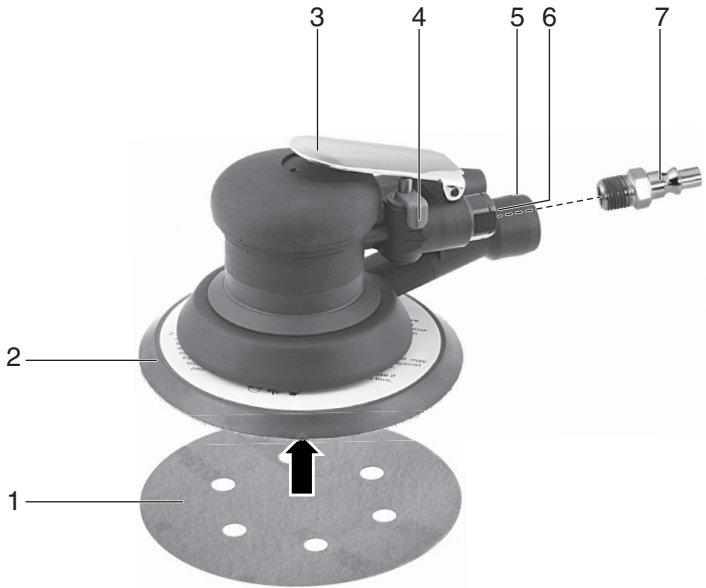

DSX 150



de	Originalbetriebsanleitung	4	no	Originalbruksanvisning	36
en	Original instructions	10	pl	Oryginalna instrukcja obsługi	41
fr	Notice d'utilisation originale	15	hu	Eredeti üzemeltetési útmutató	47
nl	Oorspronkelijke gebruiksaanwijzing	21	ru	Оригинальное руководство по эксплуатации	52
es	Manual original	26	cs	Originální návod k použití	58
fi	Alkuperäinen käyttöohje	31	uk	Оригінальна інструкція з експлуатації	63



		DSX 150
*1) Serial Number		01558..
V₁	l/min	550
P_{max.}	bar	6,2
D	mm (in)	150 (5 ²⁹ / ₃₂)
n₀	./min	12000
S	mm (in)	5 (³ / ₁₆)
d_i	mm (in)	10 (³ / ₈)
C	“	¹ / ₄
A	mm	195 x 148 x 106
m	kg (lbs)	1,0 (2.2)
a_h/K_h	m/s²	3,57 / 1,79
L_{pA}/K_{pA}	dB(A)	86,7 / 3
L_{WA}/K_{WA}	dB(A)	97,7 / 3

 *2) 2006/42/EC
 *3) EN ISO 12100:2010, EN ISO 11148-8:2011

2022-11-17, Bernd Fleischmann
 Direktor Produktentstehung & Qualität (Vice President Product Engineering & Quality)
 *4) Metabowerke GmbH - Metabo-Allee 1 - 72622 Nuertingen, Germany

ppa. B.F.

Original instructions

1. Declaration of Conformity

Under our sole responsibility, we hereby declare that these compressed air disc sanders, identified by type and serial number *1), meet all relevant requirements of directives *2) and standards *3). Technical documents for *4) - see Page 3.

For UK only:

UK We as manufacturer and authorized person to **CA** compile the technical file, see *4) on page 3, hereby declare under sole responsibility that these compressed air disc sanders, identified by type and serial number *1) on page 3, fulfill all relevant provisions of following UK Regulations S.I. 2008/1597 and Designated Standards EN ISO 12100:2010, EN ISO 11148-8:2011.

2. Specified Use

This air tool is suitable for sanding of flat and curved surfaces, wood, plastics, non-ferrous metals, sheet steel and similar materials, spackled and painted surfaces in professional applications.

Suitable for wet and dry grinding.

The tool must only ever be operated with a compressed air supply. The maximum supply pressure specified on the air tool must never be exceeded. The air tool must not be operated using explosive, inflammable or hazardous gases. It must not be used as a lever, crushing tool or striking tool.

Any other use does not comply with the intended purpose. Unspecified use, modification of the air tool or use of parts that have not been tested and approved by the manufacturer can cause unforeseeable damage.

The user bears sole responsibility for any damage caused by improper use.

Generally accepted accident prevention regulations and the enclosed safety information must be observed.

3. General Safety Instructions



For your own protection and for the protection of your air tool, carefully observe all parts of the text that are marked with this symbol!



WARNING – Reading the operating instructions will reduce the risk of injury.

WARNING Read all safety warnings and instructions. Failure to follow all safety warnings and instructions may result in electric shock, fire and/or serious injury.

Keep all safety instructions and information for future reference.

Pass on your air tool only together with these documents.

- The user or user's employer must evaluate the specific risks associated with each application of the tool.
- You must read and understand the safety instructions before installing, operating, repairing or maintaining the tool, and also before replacing any accessory parts or carrying out any work in the vicinity of the air tool. Failure to read and follow the instructions may lead to serious injury.
- Only qualified, trained operators are authorised to install, adjust or use the air tool.
- The air tool must not be modified. Any modifications implemented may reduce the efficiency of the safety measures and increase risks for the operator.
- Never use air tools that have been damaged. Look after your air tools carefully. Regularly check that all moving parts are functioning correctly without jamming. Also regularly ensure that no parts are broken or damaged to an extent that they affect the operation of the air tool. Check that all signs and labels are legible and intelligible. Have damaged parts repaired or replaced before using the tool. Many accidents are caused by poorly maintained air tools.

4. Special Safety Instructions

4.1 Risks associated with ejected parts

Disconnect the air tool from the compressed air supply before replacing the mounted tool or accessory parts, and also before carrying out repairs or settings.

If either the workpiece, accessory parts or the air tool breaks, parts may be ejected at high speed.

While operating, maintaining or repairing the air tool, or replacing accessory parts, you must always wear impact-resistant safety goggles. The degree of protection required for each individual task must be evaluated separately in each case.

Wear a safety helmet if carrying out work above your head. Also ensure that no other people are placed at risk.

Ensure that the workpiece is securely attached.

4.2 Risks associated with items catching/getting entwined

Wear suitable clothing. Do not wear loose clothing or jewellery. Keep hair, clothing and gloves at a safe distance from the air tool and moving parts. Loose clothing, jewellery or long hair may possibly be caught in moving parts. There is a risk of injury in this case.

4.3 Risks during operation

When using the air tool, the operator's hands may be exposed to potential risk of cuts, abrasions and heat damage. To protect your hands, wear suitable gloves.

The operator and maintenance staff must be physically capable of handling the size, weight and power output of the air tool.

Make sure you hold the air tool correctly: be prepared to counter both routine and unexpected movements, so keep both hands ready.

Ensure you stand in a safe position and keep your balance at all times.

Avoid accidental operation. If the air supply is interrupted, switch off the air tool using the On/Off switch.

Only use lubricants that have been recommended by the manufacturer.

Wear personal protective equipment and always wear safety glasses. By wearing personal protective equipment such as gloves, protective clothing, a dust mask, non-skid safety shoes, a safety helmet or ear protectors, to suit the type of machine and its use, you reduce the risk of injury. Wearing this equipment is recommended.

Check the grinding wheel before each use. Do not use if cracked or broken, or if it has been dropped.

Avoid direct contact with the grinding wheel to prevent crushing or cutting your hands or other body parts. To protect your hands, wear suitable gloves.

Never operate the machine when no grinding medium is installed.

There is a risk of electrostatic discharge if the machine is used on plastic and other non-conductive materials.

Explosive or flammable dust or vapours may be generated while you work on workpieces. There is therefore a risk of explosion or fire. Always use a dust extraction or dust suppression system that is suitable for the material being processed.

4.4 Risks associated with recurring movements

When working with the air tool, you may experience an uncomfortable sensation in your hands, arms, shoulders, neck or other body parts.

Make sure you are in a comfortable position to carry out work with the air tool, check that the tool is held securely, and avoid any awkward positions that make it difficult, for example, to keep your balance. If carrying out work over an extended period, you/the operator should change position occasionally. This should help to avoid fatigue and any unpleasant sensation.

If the operator experiences persistent symptoms such as feeling unwell, aches, pains or throbbing, a prickling or burning sensation, loss of hearing, or joint stiffening, these warning signs must not be ignored. The operator should advise the employer of these symptoms and consult a qualified doctor.

4.5 Risks associated with accessory parts

Disconnect the air tool from the air supply before securing or replacing the mounted tool or accessory part.

Only use accessories that are designed for this device and that fulfil the requirements and the specifications listed in these operating instructions.

Avoid any direct contact with the mounted tool both during and after use because it may be hot or have sharp edges.

Parting grinder discs and chopping machines must not be used.

The rated speed of the mounted tool must be at least equal to the maximum speed marked on the air tool. Accessories running faster than their rated speed can break and fly apart.

Self-adhesive sanding discs must be fitted concentrically on the supporting disc.

4.6 Risks in the workplace

Slipping, tripping and falling are the main reasons for accidents in the workplace. Pay attention to surfaces that may have become slippery as a result of using the air tool, and also be careful that the air hose does not cause someone to trip.

The air tool is not designed for use in explosive environments and is not insulated against contact with sources of electric power.

Ensure that the area where you wish to work is free of power cables, gas lines or water pipes (e.g. by using a metal detector).

4.7 Risks associated with dust and vapours

The dust and vapours generated when the air tool is used may carry health risks (e.g. cancer, birth defects, asthma and/or dermatitis); it is therefore imperative that a risk assessment is carried out in relation to these risks and that suitable controls are then implemented.

The risk assessment should take into account both the dust generated while the air tool is used and any existing dust that may be raised during operation.

The air tool must be operated in accordance with the recommendations set forth in these instructions and must be maintained in order to minimise the release of dust and vapours.

The extracted air must be discharged in such a way that, in a dust-filled environment, the minimum of dust is raised.

If dust or vapours are generated, the main priority is to control these at the point where they are released.

All integral or accessory parts on the air tool that are designed to collect, extract or prevent airborne dust or vapours must be used and maintained in accordance with the manufacturer's instructions.

To avoid increasing the amount of dust or vapours generated unnecessarily, the consumables and the mounted tool must be selected, maintained and replaced in accordance with these instructions.

Use protective breathing apparatus in accordance with your employer instructions or in accordance with health and safety regulations.

4.8 Risks associated with noise

Failure to use adequate ear protectors when the noise level is high can result in lasting damage to hearing, hearing loss and other problems, such as tinnitus (ringing, whistling or buzzing in the ear).

It is vital to carry out a risk assessment in relation to these risks and to implement appropriate control measures that take the risks into account.

Appropriate risk control measures may include, for example, the use of sound-insulating materials to prevent the knocking sounds that occur on the workpieces.

Use ear protection in accordance with your employer instructions or in accordance with health and safety regulations.

The air tool must be operated in accordance with the recommendations provided in these instructions and must be maintained in order to avoid unnecessarily raising the noise level.

To avoid increasing the noise level unnecessarily, the consumables and the mounted tool must be selected, maintained and replaced in accordance with these instructions.

The integrated sound absorber must not be removed. You must ensure the sound absorber is in good working order.

4.9 Risks associated with vibration

The effects of vibrations can damage nerves and impair blood circulation in the hands and arms.

When working in cold environments, you must wear warm clothing and keep your hands warm and dry.

If you notice that the skin on your fingers or hands is numb, prickling or turning white, stop working with the air tool immediately, notify your employer and consult a doctor.

The air tool must be operated in accordance with the recommendations provided in these instructions and must be maintained in order to avoid unnecessarily raising the level of vibration.

Hold the air tool firmly but not too tightly using the required manual torque reaction: the risk of vibration is increased when the grip force is higher.

4.10 Additional safety instructions

Compressed air can cause serious injury.

Whenever the air tool is not in use, and before replacing accessory parts or when carrying out repairs, you must ensure that air supply is shut off, that the air hose is depressurised and that the air tool is disconnected from the compressed air supply.

Never direct the air jet at yourself or other people.

Whiplashing hoses can cause serious injury. Therefore always check that the hoses and their fixtures are in good condition and that they have not become loose.

If universal swivel couplings (claw couplings) are being used, locking pins are also required. You should also use whip check hose restraints in case

there is a problem with the connection between the hose and air tool or between the hoses themselves.

Ensure that the maximum pressure specified on the air tool is not exceeded.

Never carry air tools by the hose.

4.11 Additional safety instructions

- If applicable, observe any particular health and safety or accident prevention regulations governing the use of compressors and compressed air tools.
- Ensure that the maximum supply pressure specified in the Technical Specifications is not exceeded.
- Do not overload the tool – use it only within the performance range for which it was designed (see “Technical Specifications”).
- Use non-hazardous lubricants. Ensure the workplace is adequately ventilated. If there is a large amount of discharge: check the air tool and have it repaired if necessary.
- Do not operate the tool unless you are completely focused. You must be alert, pay attention to what you are doing and proceed cautiously when working with an air tool. Never use a tool when you are tired or under the influence of drugs, alcohol or medication. Just one moment’s carelessness when using the tool can cause serious injury.
- Make sure your workplace is clean and well lit. Untidy or poorly lit workplaces can cause accidents.
- Keep air tools away from children.
- Do not store the tool outdoors or in damp conditions without protection.
- Protect the air tool, especially the compressed air connection and the control elements from dust and dirt.
- Dust from material such as paint containing lead, some wood species, minerals and metal may be harmful. Contact with or inhalation of the dust may cause allergic reactions and/or respiratory diseases to the operator or bystanders. Certain kinds of dust are classified as carcinogenic, such as oak and beech dust, especially in conjunction with additives for wood conditioning (chromate, wood preservative). Material containing asbestos must only be treated by specialists.
- Use a dust extraction device where possible.
- For efficient dust collection, use a suitable Metabo vacuum cleaner together with this air tool.
- The workplace must be well ventilated.
- The use of a dust mask of filter class P2 is recommended.
- Follow national requirements for the materials you want to work with.
- Materials emitting dusts or vapours that may be harmful to health (e.g. asbestos) must not be processed.
- Secure the workpiece against slipping, e.g. with the help of clamping devices.

Information in these operating instructions is categorised as shown below:



Danger! Risk of personal injury or environmental damage.



Caution. Risk of material damage

4.12 Symbols on the air tool



Read the Operating Instructions before starting to use the machine.



Wear safety goggles.



Wear ear protectors.

5. Overview

See Page 2.

- 1 Sanding disc *
- 2 Support plate
- 3 Switch (on/off)
- 4 Setting wheel for adjusting rotational speed
- 5 Extractor connection piece
- 6 Compressed air connection with filter
- 7 Plug-in nipple 1/4"
- 8 Open end wrench

* depending on equipment/not in scope of delivery

6. Operation

6.1 Before using the tool for the first time

- Insert plug-in nipple (7).

6.2 Installation of sanding disc

Simple attachment and removal thanks to the Velcro-type fastening.

Simply press on the sanding disc such that the holes in the sanding disc (1) are aligned with the support plate (2).

Use a suitable sanding disc to achieve the best possible work results: Removal of old paint layers = P 40

Pre-sanding of wood = P 60, P 80

Finishing of wood = P 100, P 120

Sanding of veneers, sealing primer, filler, paint = P 180, P 240, P 320, P 400

6.3 Dust extraction

External dust extraction:

fit a suitable dust extractor to the extractor connection piece (5).

6.4 Using the air tool

To maximise the air tool's performance, always use compressed air hoses with an inner diameter of at least 10 mm and a maximum length of 10 m. Tool performance can be significantly impaired if the inner hose diameter is too small or if the hose is too long.



Caution. The compressed air line must not contain any water condensation.



Caution. To preserve and extend the service life of this tool, you must ensure that it is regu-

larly maintained with pneumatic oil lubricator. You can do this as follows:

- Use oiled compressed air by fitting an oil-fog lubricator.
- Without an oil-fog lubricator: manually apply oil every day via the compressed air connection. Use approx. 3-5 drops of pneumatic oil lubricator for each 15 minutes of continuous operation.

If the tool has not been in use for several days, you should manually apply about 5 drops of pneumatic oil lubricator into the compressed air connection.



Caution. Only allow the tool to run at idle speed for a brief period.

1. Fit a suitable sanding disc (1) (see Section 6.2).
2. Connect a suitable dust extractor to the extraction connection piece (5). (See Section 6.3).
3. Adjust the supply pressure (this is measured at the air outlet while the air tool is switched on). For details of the maximum permissible supply pressure, see the section on "Technical Specifications".
4. Connect the air tool to the compressed air supply.
5. To switch on: press switch (3). Adjust the rotational speed on the setting wheel (5). Adjust the rotational speed on the speed regulator (4). (The best way to determine the ideal setting is through a practical trial). To switch off: release switch (3).
6. Do not press the device too firmly against the surface being sanded. This does not improve, but rather impairs, the sanding performance.

7. Care and Maintenance



Danger! Disconnect the compressed air connection before carrying out any work.



Danger! Repair and maintenance work other than the work described in this section should only be carried out by **qualified specialists**.

- Carry out regular maintenance to ensure the safety of the air tool.
- Check that all screw fittings are seated securely, and tighten if necessary.
- Clean the filter in the compressed air connection at least once a week.
- It is recommended that you install a pressure reducer with an air-water separator and lubricator upstream of the air tool.
- If a large amount of air or oil is escaping, check the air tool and have it maintained if necessary. (See Section 9.)
- Check the rotational speed regularly and after every use. Also carry out a simple check on vibration emission.
- Avoid contact with dangerous substances that have accumulated on the tool. Wear suitable personal protective equipment and take appropriate measures to remove any dangerous substances before maintenance.

Replacing a worn support plate

- Push the open end wrench (8) between the rubber sleeve and supporting disc (2) on the retaining nut.
- Unscrew the old supporting disc (2) in an counter-clockwise direction, bracing it with the open end wrench (8).
- Screw the new supporting disc (2) tightly in a clockwise direction, bracing it with the open end wrench (8).

8. Accessories

Use only genuine Metabo accessories.

Only use accessories that are designed for this air tool and that fulfil the requirements and the specifications listed in these operating instructions.

For a complete range of accessories, see www.metabo.com or the catalogue.

9. Repairs

 **Danger!** Repairs to air tools must only be carried out by qualified specialists, using original Metabo spare parts!

If you have Metabo air tools that require repairs, please contact your Metabo service centre. For addresses see www.metabo.com.

You can download spare parts lists from www.metabo.com.

10. Environmental Protection

Observe national regulations on environmentally compatible disposal and on the recycling of disused air tools, packaging and accessories. You must not cause risks to people or the environment.

Packaging materials must be disposed of according to their labelling in accordance with municipal guidelines. Further information can be found at www.metabo.com in the "Service" section.

11. Technical Specifications

Explanatory notes on the specifications on Page 3.

Subject to change in line with technological advances.

- V_1 = Air requirement
- $p_{max.}$ = Maximum permissible supply pressure
- D = Diameter of support plate
- n_0 = Idle speed
- S = Oscillating circuit diameter
- d_i = Hose diameter (inner)
- C = Connecting thread
- A = Dimensions:
Length x Width x Height
- m = Weight

The technical specifications quoted are subject to tolerances (in compliance with the relevant valid standards).

 **Emission values**

Using these values, you can estimate the emissions from this tool and compare these with the values emitted by other tools. The actual values may be higher or lower, depending on the particular application and the condition of the tool or mounted tool. In estimating the values, you should also include work breaks and periods of low use. Based on the estimated emission values, specify protective measures for the user - for example, any organisational steps that must be put in place.

Vibration (acceleration value, frequency-weighted according to EN 28927):

a_h = Vibration emission level
 K_h = Measurement uncertainty (vibration)

Sound level (EN ISO 15744):

L_{pA} = Sound pressure level
 L_{WA} = Acoustic power level
 K_{pA}, K_{WA} = Measurement uncertainty



Wear ear protectors!