

de	Tauchsäge	Originalbetriebsanleitung	5
en	Plunge cut saw	Translation of the original operating instructions	19
fr	Scie circulaire plongeante	Traduction de la notice d'emploi originale	32
it	Sega ad immersione	Traduzione delle istruzioni d'uso originali	46
nl	Invalcirkelzaag	Vertaling van de originele gebruiksaanwijzing	60
es	Sierra de incisión	Traducción del manual de instrucciones original	73
fi	Uputussaha	Käännös alkuperäiskäyttöohjeesta	87
sv	Sänksåg	Översättning av originalbruksanvisningen	100
da	Dyksav	Oversættelse af den originale betjeningsvejledning	112



MAF02148/a

WARNING

Lesen Sie alle Sicherheitshinweise und Anweisungen. Versäumnisse bei der Einhaltung der Sicherheitshinweise und Anweisungen können elektrischen Schlag, Brand und/oder schwere Verletzungen verursachen. **Bewahren Sie alle Sicherheitshinweise und Anweisungen für die Zukunft auf.**

WARNING

Please read all safety instructions and directions. Failure to comply with the safety instructions and directions can cause electric shock, fire and/or serious injuries. **Please retain all safety instructions and directions for future reference.**

AVERTISSEMENT

Veuillez lire toutes les consignes de sécurité et instructions. Tout non-respect des consignes de sécurité et instructions risque d'être à l'origine de décharges électriques, d'incendies et/ou de blessures graves. **Conservez toutes les consignes et instructions pour pouvoir les relire à tout moment.**

AVVERTENZA

Leggere tutte le avvertenze di sicurezza e le istruzioni. La mancanza del rispetto delle avvertenze di sicurezza e delle istruzioni possono causare scossa elettrica, incendio e/o gravi lesioni. **Conservare tutte le avvertenze di sicurezza e le istruzioni per il futuro.**

WAARSCHUWING

Lees alle veiligheidsaanwijzingen en instructies. Nalatigheid bij het naleven van de veiligheidsinstructies en aanwijzingen kan elektrische schok, brand en/of ernstige letsels veroorzaken. **Bewaar alle veiligheidsaanwijzingen en instructies voor later gebruik.**

ADVERTENCIA

Lea todas las indicaciones de seguridad e instrucciones. Si no se cumplen las indicaciones de seguridad e instrucciones, se pueden producir descargas eléctricas, incendios y/o lesiones graves. **Guarda todas las indicaciones de seguridad e instrucciones para el futuro.**

VAROITUS

Lue kaikki turvaohjeet ja käyttöohjeet. Laiminlyönti turvaohjeiden ja käyttöohjeiden noudattamisessa voi aiheuttaa sähköiskun, tulipalon ja/tai vakavia vammoja. **Säilytä kaikki turvaohjeet ja käyttöohjeet tulevaisuuden varalle.**

WARNING

Läs alla säkerhetsanvisningar och anvisningar. Underlåtenhet att följa säkerhetsanvisningar och anvisningar kan orsaka elstöt, brand och/eller allvarliga personskador. **Behåll alla säkerhetsanvisningar och anvisning för framtida användning.**

ADVARSEL

Læs alle sikkerhedshenvisninger og instruktioner. En manglende overholdelse af sikkerhedshenvisningerne og instruktionerne kan føre til elektrisk stød, brand og/eller alvorlige kvæstelser. **Opbevar alle sikkerhedshenvisninger og instruktioner til fremtidig brug.**

D - EG Konformitätserklärung

Wir bescheinigen hiermit, dass die Maschine MT55 18M bl den angeführten EU-Richtlinien entspricht. Bei Konstruktion und Bau wurden die gelisteten Normen angewendet. Bevollmächtigter für die Zusammenstellung der technischen Unterlagen: Mafell AG

GB - EC Declaration of Conformity

We herewith confirm that the machine MT55 18M bl complies with the EU directives quoted. The standards listed were used for design and construction. Empowered person for the configuration of the technical documents: Mafell AG

F - Déclaration CE de conformité

Nous déclarons par la présente que la machine MT55 18M bl est conforme aux directives CE applicables comme suit. Lors de la construction, les règlements suivants ont été utilisés. Plénipotentiaires pour l'assemblage des documentations techniques: Mafell AG

I - Dichiarazione di conformità CE

Con la presente certifichiamo che la macchina MT55 18M bl è conforme alle seguenti direttive CE applicabili. Nella progettazione e la costruzione sono state applicate le seguenti norme. Responsabile per la composizione della documentazione tecnica: Mafell AG

NL - EG conformiteitsverklaring

Wij bevestigen hiermede dat de machine MT55 18M bl aan de vermelde EU-richtlijnen beantwoord. Bij constructie en bouw werden de vermelde normen toegepast. Gemachtigde voor de samenstelling van de technische documenten: Mafell AG

E - Declaración de conformidad CE

Con la presente se certifica que la máquina MT55 18M bl cumple las directivas europeas mencionadas, las cuales forman la base tanto del diseño constructivo como de los procesos de fabricación. Apoderado legal para la compilación de la documentación técnica: Mafell AG

FIN - EY-vaatimustenmukaisuusvakuutus

Vakuutamme täten, että kone MT55 18M bl vastaa mainittujen EU-direktiivien vaatimuksia. Sen suunnittelussa ja valmistuksessa on sovellettu luettelossa ilmoitettuja standardeja. Teknisten asiakirjojen laatimiseen valtuutettu henkilö: Mafell AG

S - EG Konformitetsförklaring

Vi intygar härmed att maskinen MT55 18M bl uppfyller angivna EU direktiv. De angivna normerna användes vid konstruktion och tillverkning. Befullmäktigad för sammanställningen av den tekniska dokumentationen: Mafell AG

DK - EU overensstemmelseserklæring

Vi attesterer hermed, at maskinen MT55 18M bl opfylder de angivene EU-direktiver. Konstruktion og bygning er udført iht. de angivene standarder. Person, der er befuldægtiget til at sammenstille det tekniske materiale: Mafell AG

RUS - Сертификат соответствия ЕС

Настоящим подтверждаем, что машина MT55 18M bl отвечает требованиям указанных директив ЕС. При проектировании и изготовлении применялись перечисленные нормы. Уполномоченный представитель по составлению технической документации: Mafell AG

PL - Deklaracja zgodności UE

Niniejszym potwierdzamy, że maszyna MT55 18M bl spełnia wymagania wyszczególnionych dyrektyw UE. W trakcie konstrukcji urządzenia zastosowano przedstawione normy. Pełnomocnik odpowiedzialny za zestawienie dokumentacji technicznej: Mafell AG

CZ - PROHLÁŠENÍ O SHODĚ

Tímto prohlašujeme, že stroj MT55 18M bl splňuje pokyny uvedených směrnic EU. Při plánování a sestavení byly využity uvedené normy. Za sestavení technických podkladů zodpovídá: Mafell AG

SLO - ES izjava o skladnosti

S tem izjavljamo, da stroj MT55 18M bl ustreza navedenim direktivam EU. Pri konstrukciji in izdelavi so uporabljeni našteti standardi. Za sestavo tehnične dokumentacije je pooblaščen podjetje: Mafell AG



2006/42/EG
2014/30/EU
2011/65/EU

EN 62841-1, EN 62841-2-5, EN 55011, EN 12100,
EN 847-1

MT55 18M bl

Art.-Nr.: 91B401, 91B402, 91B421, 91B423, 91B425

Mafell AG
D - 78727 Oberndorf, den 30.08.2019

Dipl.-Ing. Matthias Krauss
Vorstandsvorsitzender / CEO

i. V. Dipl.-Ing. Harald Schmid, MBA
Leitung Entwicklung und Konstruktion

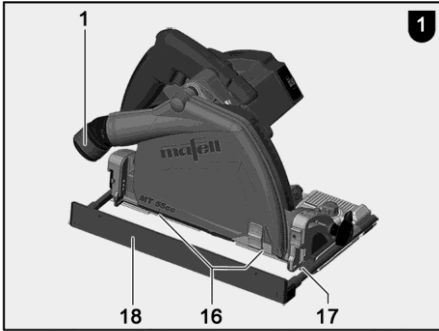

MAF02149/a

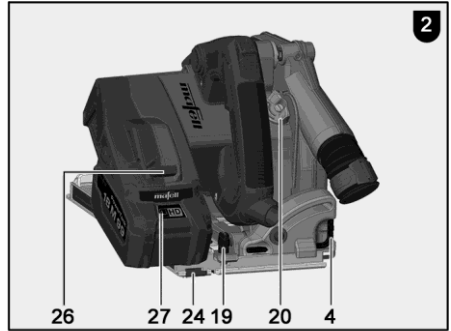

MAF02150/b

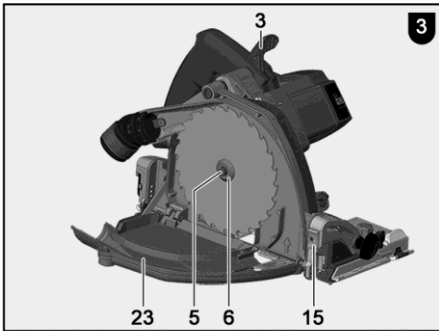

MAF02151/a

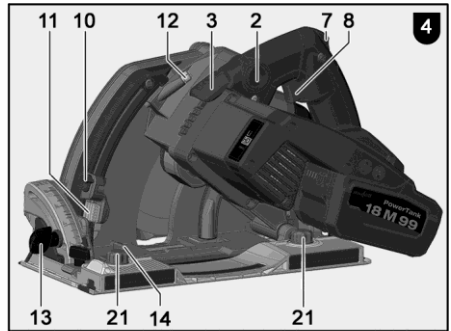

MAF02152/b

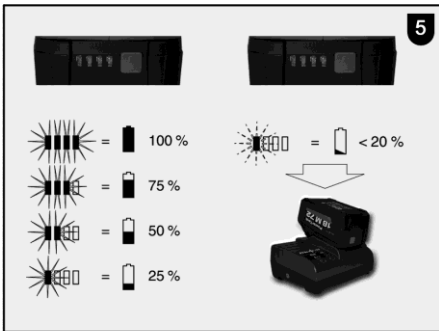

MAF02153/a

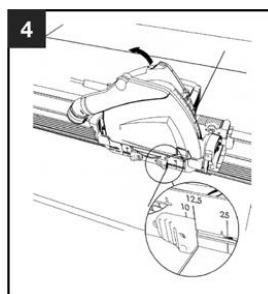
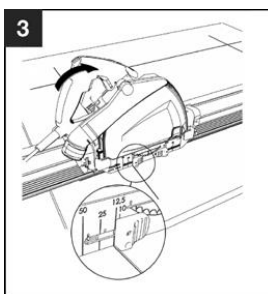
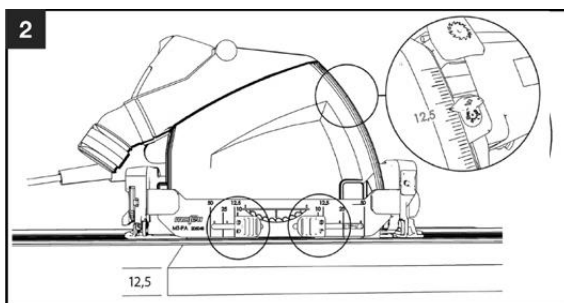
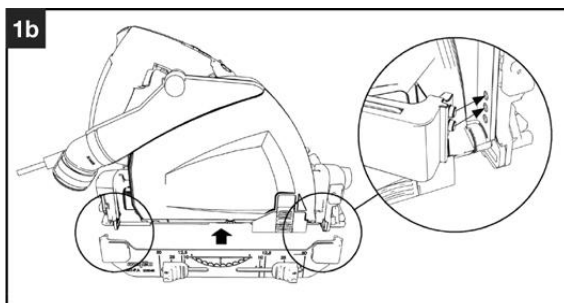
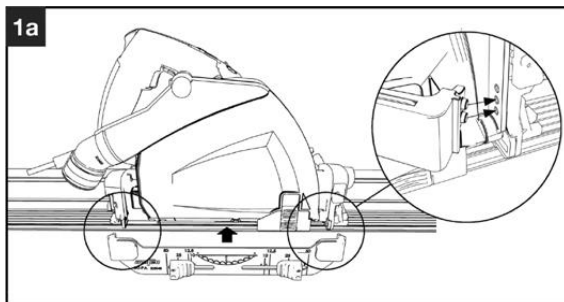

Table of Contents

1	Signs and symbols	20
2	Product information	20
2.1	Manufacturer's data	20
2.2	Machine identification	20
2.3	Technical data	21
2.4	Emissions	21
2.5	Scope of supply	21
2.6	Safety devices	22
2.7	Use according to intended purpose	22
2.8	Residual risks	22
3	Safety instructions	22
4	Setting / Adjustment	25
4.1	Charging the rechargeable battery	25
4.2	Fitting the rechargeable battery	25
4.3	Removing the rechargeable battery	25
4.4	Chip extraction	25
4.5	Saw blade selection	26
4.6	Saw blade change	26
5	Operation	26
5.1	Initial operation	26
5.2	Switching on and off	26
5.3	Cutting depth adjustment	26
5.4	Setting for bevel cuts	27
5.5	Plunge cuts	27
5.6	Sawing according to tracings	27
5.7	Sawing with the parallel stop	27
5.8	Scoring with the guide rail (special accessories)	27
5.9	Working with the diamond saw blade in fibre cement board (special accessories)	28
5.10	Working with guide rails	28
5.11	Working with the position indicator MT-PA	28
6	Service and maintenance	28
6.1	Storage	28
6.2	Transport	28
6.3	Disposal of rechargeable batteries/batteries	28
7	Troubleshooting	29
8	Optional accessories	31
9	Exploded drawing and spare parts list	31

1 Signs and symbols



This symbol appears at places where you will find instructions for your own safety.

Non-compliance with these instructions may result in very serious injuries.



This symbol indicates a potentially hazardous situation.

If this situation is not avoided, the product or objects in its vicinity may get damaged.



This symbol indicates tips for the user and other useful information.

2 Product information

for machines with Art.-No. 91B401, 91B402, 91B421 or 91B425

2.1 Manufacturer's data

MAFELL AG, Beffendorfer Straße 4, D-78727 Oberndorf / Neckar, Phone +49 (0)7423/812-0, Fax +49 (0)7423/812-218

2.2 Machine identification

All details required for machine identification are available on the attached rating plate.



CE symbol to document compliance with the basic safety and health requirements according to Appendix I of the Machinery Directive.



For EU countries only

Do not dispose of electrical tools together with domestic waste!

In accordance with the European directive 2002/96/EC on waste electrical and electronic equipment and transposition into national law, obsolete electrical tools must be collected separately and recycled in an environmentally-compatible manner.



To reduce the risk of injury, please read the operating instructions.



Protect the rechargeable battery from heat, excessive solar radiation, fire, frost, water and humidity.

Protect rechargeable battery packs from humidity!



Protect rechargeable battery packs from fire!

There is danger of explosion!



Cordless Alliance System (=CAS) is a cross-manufacturer battery pack system. Further information is available at www.cordless-alliance-system.com

2.3 Technical data

Nominal voltage	18 V $\overline{=}$
Saw blade speed while idling	4850 rpm
Cutting depth 0° / 45°	0 – 57 mm / 0 – 40.5 mm
Tilting saw unit	-1° / 0° – 48°
Saw blade diameter max./min.	162 / 149 mm (6.28 / 5.86 in.)
Saw blade base body thickness	1.2 mm (0.05 in.)
Tool cutting width	1.8 mm (0.07 in.)
Saw blade mounting hole	20 mm (0.79 in.)
Hose connector diameter	35 mm (1.38 in.)
Weight with rechargeable battery (without parallel stop)	4.5 kg (9.92 lbs)
Dimensions (W x L x H)	250 x 330 x 215 mm (9.84 x 12.99 x 8.46 in.)

2.4 Emissions

The values stated are emission levels. Although there is a correlation between emission and imission level, it cannot be reliably derived from this whether additional precautions are necessary. Factors influencing the current imission level existing at the workplace comprise the duration of exposure, the room characteristic, other sources of noise, etc. such as e.g. the number of machines and other adjacent machining operations. In addition, the permissible imission level may differ from country to country. This information is nevertheless suitable for providing the machine user with an improved assessment of the hazard and risk.

2.4.1 Noise emission specifications

Noise emission values determined according to EN 62841:

Sound pressure level	$L_{PA} = 90 \text{ dB (A)}$
Uncertainty	$K_{PA} = 3 \text{ dB (A)}$
Sound power level	$L_{WA} = 101 \text{ dB (A)}$
Uncertainty	$K_{WA} = 3 \text{ dB (A)}$

The noise measurement was recorded using the saw blade included in the standard equipment.

2.4.2 Vibration specifications

The typical hand-arm vibration is less than 2.5 m/s².

2.5 Scope of supply

Plunge cut saw MT55 18M bl complete with:

- 1 carbide-tipped circular saw blade \varnothing 162 mm (6.38 in.), 48 teeth
- 1 parallel stop
- 1 service tool in bracket on the machine
- 1 carrying case
- 1 operating manual
- 1 folder "Safety instructions"
- 1 position indicator MT-PA
- 1 chip bag
- 1 charger APS 18M for Art.No. 91B401, 91B421, 91B425

2.6 Safety devices



Danger

These devices are required for the machine's safe operation and may not be removed or rendered inoperative.

The machine is equipped with the following safety devices:

- Saw guard
- Large base plate
- Handles
- Index mechanism and brake
- Hose connector

2.7 Use according to intended purpose

The plunge cut saw is exclusively suitable for longitudinal and cross cutting of solid wood.

Panel materials such as chip board, core board and MDF board can also be processed. Only use the saw blades approved by Mafell according to EN 847-1 in the specified \varnothing range.

In conjunction with the diamond saw blade you can also cut fibre cement board.

Any other use than described above is not permissible. The manufacturer cannot be held liable for any damage arising from such other use.

In order to use the machine as intended, comply with the operating, maintenance, and repair instructions specified by Mafell.

Only use saw blades with a speed marking that corresponds to or is higher than the speed specified on the power tool

Use only original Metabo or CAS (Cordless Alliance System) battery packs and accessories.

Battery packs marked with CAS are 100% compatible with CAS devices (Cordless Alliance System).

2.8 Residual risks



Danger

Even if used in accordance with its intended purpose and despite conforming with the safety instructions, residual risks caused by the intended use will always remain.

- Touching the saw blade in the vicinity of the starting aperture below the base plate.
- Touching the part of the saw blade that protrudes below the workpiece when cutting.
- Touching of turning parts from the side: saw blade, clamping flange and flange screw.
- Machine backlash if the blade gets stuck in the workpiece.
- Breakage of the saw blade and risk of the blade or pieces of the blade being hurled away.
- Accidental activation if rechargeable battery is not unplugged.
- Hearing can be impaired when working for long periods without ear protectors.
- Emission of harmful wood dusts during longer operation without extraction.

3 Safety instructions



Danger

Always observe the following safety instructions and the safety regulations applicable in the respective country of use!

General instructions:

- Children and adolescents must not operate this machine. This rule does not apply to young persons receiving training and being supervised by an expert.
- Never work without the protection devices stipulated for the respective operating sequence and do not effect any modifications on the machine that could impair safety.

- Examine the workpiece for foreign objects. Never attempt to cut into nails or other metal objects.
- Protect the machine and the rechargeable batteries from humidity!
- Do not throw the rechargeable batteries into a fire!
- Do not use any defective or deformed rechargeable batteries!
- Do not open the rechargeable batteries!
- Do not touch the contacts of the rechargeable batteries and do not short-circuit them!
- A slightly acidic, combustible liquid may leak from defective li-ion rechargeable batteries! If any battery liquid is leaking and comes in contact with the skin, immediately rinse with a copious amount of water. If any battery liquid gets into your eyes, rinse with clean water and immediately consult a doctor for medical treatment!
- Remove the rechargeable batteries from the machine before carrying out any setting, retooling, maintenance or cleaning tasks.
- Ensure that the machine is switched off when you push in the rechargeable battery.
- Please remove the rechargeable battery from the machine if the machine is put down, transported or stored unattended.

Do not use:

- Cracked and misshapen saw blades.
- Saw blades made of high speed steel (HSS saw blades).
- Blunt saw blades as they impose an excessive load on the motor.
- Saw blades with a base body with a thickness greater than, or a cutting width (setting) less than, the thickness of the riving knife / splitter.
- Saw blades which are not suitable for the saw blade's idling speed.
- Grinding discs

Instructions on the use of personal protective equipment:

- Always wear ear protectors during work.
- Always wear a dust mask during work.

Instructions on operation:

Sawing method



- **Keep hands away from cutting area and the blade. Keep your second hand on auxiliary handle, or motor housing.** If both hands are holding the saw, they cannot be cut by the blade.
- **Do not reach underneath the workpiece.** The guard cannot protect you from the blade below the workpiece.
- **Adjust the cutting depth to the thickness of the workpiece.** Less than a full tooth of the blade teeth should be visible below the workpiece.
- **Never hold the workpiece in your hands or across your leg while cutting. Secure the workpiece to a stable platform.** It is important to support the work properly to minimise body exposure, blade binding, or loss of control.
- **Hold the power tool by insulated gripping surfaces, when performing an operation where the cutting tool may contact hidden wiring or its own cord.** Contact with a "live" wire will also make exposed metal parts of the power tool "live" and could give the operator an electric shock.
- **When ripping, always use a rip fence or straight edge guide.** This improves the accuracy of cut and reduces the chance of blade binding.
- **Always use blades with correct size and shape (diamond versus round) of arbour holes.** Blades that do not match the mounting hardware of the saw will run off-centre, causing loss of control.
- **Never use damaged or incorrect blade washers or bolt.** The blade washers and bolt were specially designed for your saw, for optimum performance and safety of operation.

Kickback causes and related warnings

- kickback is a sudden reaction to a pinched, jammed or misaligned saw blade, causing an uncontrolled saw to lift up and out of the workpiece toward the operator;
- When the blade is pinched or jammed tightly by the kerf closing down, the blade stalls and the motor reaction drives the unit rapidly back toward the operator;
- if the blade becomes twisted or misaligned in the cut, the teeth at the back edge of the blade can dig into the top surface of the wood causing the blade to climb out of the kerf and jump back toward the operator.

Kickback is the result of saw misuse and/or incorrect operating procedures or conditions and can be avoided by taking proper precautions as given below.

- **Maintain a firm grip with both hands on the saw and position your arms to resist kickback forces. Position your body to either side of the blade, but not in line with the blade.** Kickback could cause the saw to jump backwards, but kickback forces can be controlled by the operator, if proper precautions are taken.
- **When blade is binding, or when interrupting a cut for any reason, release the trigger and hold the saw motionless in the material until the blade comes to a complete stop. Never attempt to remove the saw from the work or pull the saw backward while the blade is in motion or kickback may occur.** Investigate and take corrective actions to eliminate the cause of blade binding.
- **When restarting a saw in the workpiece, centre the saw blade in the kerf so that the saw teeth are not engaged into the material.** If a saw blade binds, it may walk up or kickback from the workpiece as the saw is restarted.
- **Support large panels to minimise the risk of blade pinching and kickback.** Large panels tend to sag under their own weight. Supports must be placed under the panel on both sides, near the line of cut and near the edge of the panel.

- **Do not use dull or damaged blades.** Unsharpened or improperly set blades produce narrow kerf causing excessive friction, blade binding and kickback.
- **Blade depth and bevel adjusting locking levers must be tight and secure before making the cut.** If blade adjustment shifts while cutting, it may cause binding and kickback..
- **Use extra caution when sawing into existing walls or other blind areas.** The protruding blade may cut objects that can cause kickback.

Guard function

- **Check the guard for proper closing before each use. Do not operate the saw if the guard does not move freely and enclose the blade instantly. Never clamp or tie the guard so that the blade is exposed.** If the saw is accidentally dropped, the guard may be bent. Check to make sure that the guard moves freely and does not touch the blade or any other part, in all angles and depths of cut.
- **Check the operation and condition of the guard return spring. If the guard and the spring are not operating properly, they must be serviced before use.** The guard may operate sluggishly due to damaged parts, gummy deposits, or a build-up of debris.
- **Assure that the base plate of the saw will not shift while performing a "plunge cut".** Blade shifting sideways will cause binding and likely kick back.
- **Always observe that the lower guard is covering the blade before placing the saw down on bench or floor.** An unprotected, coasting blade will cause the saw to walk backwards, cutting whatever is in its path. Be aware of the time it takes for the blade to stop after switch is released.

Instructions on service and maintenance:

- Regularly cleaning the machine, especially the adjusting devices and guides, constitutes an important safety factor.
- Only original MAFELL spare parts and accessories may be used. Otherwise the manufacturer will not

accept any warranty claims and cannot be held liable.

4 Setting / Adjustment

4.1 Charging the rechargeable battery

Check whether the rated voltage of the rechargeable battery agrees with the information specified on the machine.

Rechargeable battery and charger are matched to each other. Only use the MAFELL – APS 18 chargers for recharging.

Before using a new machine, first of all charge the rechargeable battery.

A description of how to start up and charge the APS 18 can be found in the appended instructions "APS 18 rechargeable power station".

The rechargeable battery is equipped with a temperature monitoring system. This guarantees that the rechargeable battery is only charged in the temperature range between 0°C and 50°C. This achieves a long service life for the rechargeable battery.

A considerably shortened operating time per charging procedure indicates that the rechargeable battery is spent and needs to be replaced.



Danger

Explosion hazard

Protect the rechargeable battery from heat, fire and moisture.

Do not place the rechargeable battery onto heating appliances and do not expose the rechargeable battery to strong solar radiation for a longer period of time. Temperatures above 50°C are detrimental to the rechargeable battery. Allow a heated rechargeable battery to cool down before charging it.

The optimum storage temperature ranges between 10°C and 30°C.



Do not open the rechargeable battery and protect it from impacts. Keep the rechargeable battery in a dry and frost-proof place.



Danger

Cover the rechargeable battery's contacts if it is stored outside the charger. There is a fire and explosion hazard in case of a short circuit caused by metallic bridging.



Follow the instructions for the protection of the environment.

4.2 Fitting the rechargeable battery

Slide the charged rechargeable battery into the battery guide next to the handle until it perceptibly engages.



Before using the machine, convince yourself that the rechargeable battery is firmly seated in the machine.

4.3 Removing the rechargeable battery

Unlock the rechargeable battery by pressing the locking lever 26 (Fig. 2) and pull it out of the battery guide.



Do not use force to do so.

4.4 Chip extraction



Danger

Substances that are harmful to health must be taken up with an M-suction device.

Connect the machine to a suitable external dust extractor during all work generating a considerable amount of dust. The air velocity must be at least 20 m/s (65.6 ft / sec.).

The internal diameter of hose connector 1 (Fig. 1) is 35 mm (1 3/8 in.).

The chip bag can be used for self-generated dust extraction when briefly carrying out work that generates a low amount of dust.

4.5 Saw blade selection

Use a sharp tool to obtain a good cut quality and select a tool from the following list according to material and application:

For cuts along and across the grain in soft or hard wood:

- Circular saw blade carbide Ø 160 x 1.8 x 20 mm (6.30 x 0.07 x 0.79 in.), 32 teeth

For cuts especially along the grain in soft or hard wood:

- Circular saw blade carbide Ø 160 x 1.8 x 20 mm (6.30 x 0.07 x 0.79 in.), 16 teeth

For cuts especially across the grain in soft or hard wood:

- Circular saw blade carbide Ø 162 x 1.8 x 20 mm (6.38 x 0.07 x 0.79 in.), 48 teeth

For cuts in fibre cement board:

- Diamond saw blade Ø 160 x 3.0 x 20 mm (6.30 x 0.12 x 0.79 in.), 4 teeth

4.6 Saw blade change



Danger

Unplug the rechargeable battery for all service work.

- To fold the saw guard cover 23 (Fig.3) down on the side, press push-button 2 (Fig. 4) and pull up the locking lever 3. Pulling the locking lever automatically locks the saw shaft and locks the gearshift lever.
- Use the Allen key 4 (brackets Fig. 2) to release the flange screw 5 (Fig. 3) **counter clockwise**. Remove the screw and the front clamping flange 6.
- You can now remove the saw blade by lifting it to the front.
- The clamping flanges must be free of adhering parts.
- Pay attention to the sense of rotation when inserting the saw blade.
- Afterwards, mount the clamping flange, attach the flange screw and tighten it by **clockwise** turning.

- Lock the saw guard cover. To this end, close the cover and press the locking lever 3 (Fig.3) downwards.

5 Operation

5.1 Initial operation

Personnel entrusted to work with the machine must be made aware of the operating instructions, calling particular attention to the chapter "Safety instructions".

5.2 Switching on and off

- **Switching on:** Press the switch-on lock 7 (Fig. 4) forward to unlock it. Then actuate switch trigger 8 (Fig. 4) when the switch-on lock is pressed.

As this is a switch without locking device, the machine will only run for as long as this shift lever is pressed.

The built-in electronic system provides for jerk-free acceleration when the machine is switched on and under load readjusts the speed to the fixed setting.

In addition, this electronic system adjusts the motor down in case of overload, i.e. the saw blade will stop. Switch the machine off then. Then switch the machine on again and continue sawing at a reduced feed speed.

- **Switching off:** Release switch trigger 8 (Fig. 4) to switch off the machine.

5.3 Cutting depth adjustment

The cutting depth is continuously variable between 0 and 57 mm (0 to 2 ¼ in.), graduated in 1 mm steps.

Proceed as follows:

- Adjust the indicator 10 (Fig. 4) by turning it into the top or bottom position, depending on whether you are working with or without the guide rail.
- Set the cutting depth with the depth stop 11 according to the scale. The limit stop has a 1 mm latching mechanism.
- In order to set intermediate measurements, you can turn the cylinder screw 12 (Fig. 4) with the Allen key 4 (retaining bracket Fig. 2). One turn corresponds to 1 mm change in cutting depth.



Always set the cutting depth approx. 2 to 5 mm (5/64 to 13/64 in.) larger than the material thickness to be cut.

5.4 Setting for bevel cuts

For bevel cuts, the saw unit can be set to any angle between 0° and 45°.

- Unfasten the wing screw 13 (Fig. 4).
- Adjust the angle according to the scale on the segment for tilting.
- Afterwards, tighten the wing screw 13.

In addition, the machine can be tilted to -1° or 48°.

- To tilt to -1°, pull the slide bar 14 (Fig. 4) backwards in the direction of the arrow and hold on to it.
- Tilt the machine to -1°.
- To tilt the machine to 48°, press the limit stop 15 (Fig. 3) downwards.
- Tilt the machine to 48°.
- 45° and 0°- limit stop are automatically reset after they have been traversed.

5.5 Plunge cuts



Danger

Risk of backlash during plunge cuts! Prior to plunging, place the machine with the rear edge of its base plate against a limit stop fastened on the workpiece. When using the guide rail (special accessories) you must fasten the limit stop available as special accessory on the guide rail. Keep a firm hold on the machine handle during plunging and push the saw lightly forward!

- The markings 16 (Fig. 1) on the bottom saw guard and on the slide bar serve as orientation for the cutting area of the completely plunged saw blade if the guide rail (special accessories) is used.

5.6 Sawing according to tracings

The figure is equipped with a tracked score indicator 17 (Fig. 1) both for straight cuts and for bevel cuts. This tracing edge corresponds to the saw blade's inside.

- Secure the workpiece against shifting and arrange the workpiece supports such that the saw blade is running freely underneath the workpiece.
- Hold the machine by its handle and place the front part of its base plate onto the workpiece.
- Switch on the plunge cut saw (see Chapter 5.2). Plunge to the set cutting depth and slide the machine evenly forward in the direction of the cut.
- When the cut is completed, switch off the saw by releasing the gearshift lever 8 (Fig. 4). Tilt the saw unit back into the top locked position.

5.7 Sawing with the parallel stop

When making parallel cuts, the parallel guide fence 18 (Fig. 1) serves to saw parallel to an already existing edge. The guide fence can be attached to the left or right of the machine. The cutting range on the right-hand side amounts to approx. 140 mm (5 ½ in.) and on the left-hand side to approx. 295 mm (11 5/8 in.).

- Once you have unfastened the wing screws you can adjust the cutting width 19 (Fig. 2) by moving the guide fence accordingly and afterwards retightening the wing screws.

In addition, by simply turning it around (guide face for the workpiece edge points upwards), the parallel stop can also be used as double support to improve guidance of the plunge cut saw. Now the machine can be guided along a lath that is fastened on the workpiece.

5.8 Scoring with the guide rail (special accessories)



In case of panel materials you can achieve a clean cut if you score. Use a suitable saw blade (see Chapter 4.5).

To avoid the surface from tearing out, proceed as follows:

- Fasten the guide rail on the workpiece.
- Tilt the locking lever 20 (Fig. 2) clockwise up to the limit stop. The scoring depth is now set to approx. 3 mm (1/8 in.).
- Place the machine with the guide groove onto the guide rail.
- Set the cutting depth - take into account the guide rail thickness (see Chapter 5.3).
- Score the board. Tilt the locking lever 20 (Fig. 2) counter clockwise up to the limit stop.
- Plunge to the preset cutting depth and saw the full board thickness.

5.9 Working with the diamond saw blade in fibre cement board (special accessories)

Proceed as follows:

- Use a suitable saw blade (see Chapter 4.5).
- Exchange the saw blade (see Chapter 4.6).



The diamond saw blade was developed for fibre cement board. The diamond-fitted teeth are more delicate than the teeth of the HM saw blade. This is why you are working with a guide rail.

5.10 Working with guide rails

- To achieve more accurate guidance, set the guide clearance with the two setting wheels 21 (Fig. 4).

The plunge cut saw can be used to work with the guide rails that are available as special accessories.

In addition, it is possible to use some rails that are freely available on the market.

- To do so, unscrew the screws and remove the insert 24 (Fig. 2).

5.11 Working with the position indicator MT-PA

For pictograms in this regard see page 4.

6 Service and maintenance



Danger

Unplug the rechargeable battery for all service work.

MAFELL machines are designed to be low in maintenance.

The ball bearings used are greased for life. When the machine has been in operation for a longer period of time, we recommend to hand the machine in at an authorised MAFELL customer service shop for inspection.

Only use our special grease, order No. 049040 (1 kg tin) for all greasing points.

6.1 Storage

If the machine is not used for a longer period of time, it has to be carefully cleaned. Spray bright metal parts with a rust inhibitor.

6.2 Transport

The contained lithium-ion batteries are subject to the Dangerous Goods Legislation requirements. The user can transport the batteries by road without further requirements.

When being transported by third parties (e.g.: air transport or forwarding agency), special requirements on packaging and labelling must be observed. For preparation of the item being shipped, consulting an expert for hazardous material is required.

Dispatch batteries only when the housing is undamaged. Tape or mask off open contacts and pack up the battery in such a manner that it cannot move around in the packaging.

Please also observe possibly more detailed national regulations.

6.3 Disposal of rechargeable batteries/batteries



The machine, rechargeable batteries, accessories and packaging should be sorted for environmental-friendly recycling.

Do not dispose of power tools and batteries/rechargeable batteries into household waste!

Only for EC countries:



According to the European Guideline 2002/96/EC, power tools that are no longer usable, and according to the European Guideline 2006/66/EC, defective or used battery packs/batteries, must be collected separately and disposed of in an environmentally correct manner.

Battery packs/batteries:

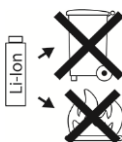

Li-Ion:

Please observe the instructions in section "Transport", page 28.

Subject to change without notice.

7 Troubleshooting



Danger

Determining the causes for existing defects and eliminating these always requires increased attention and caution. Unplug the rechargeable battery beforehand!

Some of the most frequent defects and their causes are listed in the following chart. In case of other defects, contact your dealer or the MAFELL customer service.

Defect	Cause	Elimination
Machine cannot be switched on	Discharge the rechargeable battery	Charge the rechargeable battery
	Rechargeable battery not engaged in end position	Allow rechargeable battery to engage completely
Rechargeable battery almost empty, an LED on the rechargeable battery is flashing.	Electronic system protects the rechargeable battery from deep discharge.	Press key 22 to check (Fig. 1 + 3). If only one LED is still glowing, recharge the rechargeable battery.
Overload, machine switches off.	A sustained load has overheated the machine or the rechargeable battery. A warning signal is sounded (constant bleeping). It will go out after max. 30 seconds or after the switch trigger is released.	Allow the machine and the rechargeable battery to cool down. The rechargeable battery can be cooled down much faster with a charger with air cooling. The machine can also be cooled down much faster by using a different rechargeable battery and idling the machine.
The machine switches off at a sudden increase in load.	The sudden increase in load also causes the current that is required for the machine to rise. This rise in current, which occurs when there is a sudden blockage or backlash, is measured and then leads to the machine being switched off.	Switch off the machine by releasing the switch trigger. Afterwards, you can switch the machine back on again and resume work as normal. Try to avoid further blockages.

Defect	Cause	Elimination
Saw blade jams as the machine is advanced	Feed rate too fast	Reduce feed speed
	Blunt saw blade	Release the switch immediately. Remove the machine from the workpiece and replace the saw blade
	Tension in the workpiece	
	Poor machine guidance	Use parallel stop
	Uneven workpiece surface	Straighten the surface
Burn marks on the cut surfaces	The saw blade used is unsuitable for the task or blunt	Replace saw blade
Chip ejection blocked	Wood is too damp	
	Extended operation without extraction	Connect machine to an external extraction, e.g. portable dust extractor
Sudden smoke emission from the motor casing	Overload of the machine's electronic system	Interrupt the power supply by removing the battery pack. The smoke emission stops. Do not insert a rechargeable battery! Avoid inhaling the smoke!

8 Optional accessories

- | | |
|--|------------------|
| - Saw blade carbide Ø 160 x 1.8 x 20, 16 teeth (longitudinal cut) | Order No. 092539 |
| - Saw blade carbide Ø 160 x 1.8 x 20, 24 teeth (longitudinal and crosscuts) | Order No. 092533 |
| - Saw blade carbide Ø 160 x 1.8 x 20, 32 teeth (longitudinal and crosscuts) | Order No. 092552 |
| - Saw blade carbide Ø 160 x 1.8 x 20, 56 teeth (crosscut) | Order No. 092553 |
| - Saw blade carbide Ø 162 x 1.8 x 20, 48 teeth (crosscut) | Order No. 092584 |
| - Saw blade carbide Ø 160 x 1.8 x 20, 48 teeth FZ/TR for sawing Trespa (laminated panels) | Order No. 092569 |
| - Saw blade DIA Ø 160 x 3.0 x 20, 4 teeth | Order No. 092474 |
| - Guide rail F 80, 800 mm long | Order No. 204380 |
| - Guide rail F 110, 1100 mm long | Order No. 204381 |
| - Guide rail F 160, 1600 mm long | Order No. 204365 |
| - Guide rail F 210, 2100 mm long | Order No. 204382 |
| - Guide rail F 310, 3100 mm long | Order No. 204383 |
| - Aerofix F-AF 1 | Order No. 204770 |
| - Sliding bevel F-WA | Order No. 205357 |
| - Akku-PowerTank 18 M 144 LiHD | Order No. 094498 |
| - Akku-PowerTank 18 M 99 LiHD | Order No. 094503 |
| - Accessories for guide rail: | |
| - Screw clamp F-SZ100MM (2 x) | Order No. 205399 |
| - Connecting piece F-VS | Order No. 204363 |
| - Rail bag 160 | Order No. 204626 |
| - Rail bag kit F80/160 consisting of: F80 + F160 + connecting piece + 2 screw clamps + rail bag | Order No. 204748 |
| - Rail bag kit F80/160 with sliding bevel consisting of: F80 + F160 + connecting piece + sliding bevel + 2 screw clamps + rail bag | Order No. 204749 |
| - Rail bag kit F160/160 consisting of: 2 x F160 + connecting piece + 2 screw clamps + rail bag | Order No. 204805 |
| - Backlash stop F-RS | Order No. 202867 |
| - Position indicator MT-PA | Order No. 205398 |
| - Rechargeable power station APS 18M + | Order No. 094439 |
| - Rechargeable power station APS 18M + GB | Order No. 094440 |

9 Exploded drawing and spare parts list

The corresponding information in respect of spare parts can be found on our homepage: www.mafell.com