

de	Handkreissäge	Originalbetriebsanleitung	6
en	Portable circular saw	Translation of the original operating instructions	18
fr	Scie circulaire portative	Traduction de la notice d'emploi originale	29
it	Sega circolare portatile	Traduzione delle istruzioni d'uso originali	41
nl	Handcirkelzaag	Vertaling van de originele gebruiksaanwijzing	53
es	Sierra circular manual	Traducción del manual de instrucciones original	65
fi	Käsisirkkeli	Käännös alkuperäiskäyttöohjeesta	77
sv	Cirkelsåg	Översättning av originalbruksanvisningen	88
da	Håndrundsav	Oversættelse af den originale betjeningsvejledning	99
ru	Ручная дисковая пила	Перевод оригинальной инструкции по эксплуатации	110
cs	Ruční kotoučová pila	Překlad původního provozního návodu	122
pl	Pilarka tarczowa	Tłumaczenie oryginalnej instrukcji obsługi	133
sl	Ročna krožna žaga	Prevod izvirnih navodil za uporabo	145



MAF01516/a

WARNING

Lesen Sie alle Sicherheitshinweise und Anweisungen. Versäumnisse bei der Einhaltung der Sicherheitshinweise und Anweisungen können elektrischen Schlag, Brand und/oder schwere Verletzungen verursachen. **Bewahren Sie alle Sicherheitshinweise und Anweisungen für die Zukunft auf.**

WARNING

Please read all safety instructions and directions. Failure to comply with the safety instructions and directions can cause electric shock, fire and/or serious injuries. **Please retain all safety instructions and directions for future reference.**

AVERTISSEMENT

Veuillez lire toutes les consignes de sécurité et instructions. Tout non-respect des consignes de sécurité et instructions risque d'être à l'origine de décharges électriques, d'incendies et/ou de blessures graves. **Conservez toutes les consignes et instructions pour pouvoir les relire à tout moment.**

AVVERTENZA

Leggere tutte le avvertenze di sicurezza e le istruzioni. La mancanza del rispetto delle avvertenze di sicurezza e delle istruzioni possono causare scossa elettrica, incendio e/o gravi lesioni. **Conservare tutte le avvertenze di sicurezza e le istruzioni per il futuro.**

WAARSCHUWING

Lees alle veiligheidsaanwijzingen en instructies. Nalatigheid bij het naleven van de veiligheidsinstructies en aanwijzingen kan elektrische schok, brand en/of ernstige letsels veroorzaken. **Bewaar alle veiligheidsaanwijzingen en instructies voor later gebruik.**

ADVERTENCIA

Lea todas las indicaciones de seguridad e instrucciones. Si no se cumplen las indicaciones de seguridad e instrucciones, se pueden producir descargas eléctricas, incendios y/o lesiones graves. **Guardé todas las indicaciones de seguridad e instrucciones para el futuro.**

VAROITUS

Lue kaikki turvaohjeet ja käyttöohjeet. Laiminlyönti turvaohjeiden ja käyttöohjeiden noudattamisessa voi aiheuttaa sähköiskun, tulipalon ja/tai vakavia vammoja. **Säilytä kaikki turvaohjeet ja käyttöohjeet tulevaisuuden varalle.**

VARNING

Läs alla säkerhetsanvisningar och anvisningar. Underlåtenhet att följa säkerhetsanvisningar och anvisningar kan orsaka elstöt, brand och/eller allvariga personskador. **Behåll alla säkerhetsanvisningar och anvisning för framtida användning.**

ADVARSEL

Læs alle sikkerhedshenvisninger og instruktioner. En manglende overholdelse af sikkerhedshenvisningerne og instruktionerne kan føre til elektrisk stød, brand og/eller alvorlige kvæstelser. **Opbevar alle sikkerhedshenvisninger og instruktioner til fremtidig brug.**

ПРЕДУПРЕЖДЕНИЕ

Прочитайте все правила и инструкции по технике безопасности. Несоблюдение этих правил и инструкций по технике безопасности может привести к поражению электрическим током, возгоранию и/или другим серьезным травмам. **Сохраните все правила и инструкции по технике безопасности для дальнейшего использования.**

OSTRZEŻENIE

Przeczytać wszystkie przepisy bezpieczeństwa i wskazówki. Zaniedbanie przestrzegania przepisów bezpieczeństwa i wskazówek może prowadzić do porażenia prądem, pożaru i/lub ciężkich zranień. **Zachować wszystkie przepisy bezpieczeństwa i wskazówki na przyszłość.**

UPOZORNĚNÍ

Přečtěte si všechna bezpečnostní upozornění a pokyny. Zanedbání bezpečnostních upozornění a pokynů může způsobit zásah elektrickým proudem, požár a/nebo vážná zranění. **Všechna bezpečnostní upozornění a pokyny si ponechejte pro pozdější použití.**

OPOZORILO

Preberite vsa varnostna opozorila in napotke. Neupoštevanje varnostnih opozoril in napotkov lahko povzroči udar električnega toka, požar in/ali hude telesne poškodbe. **Vsa varnostna opozorila in napotke shranite za prihodnjo uporabo.**

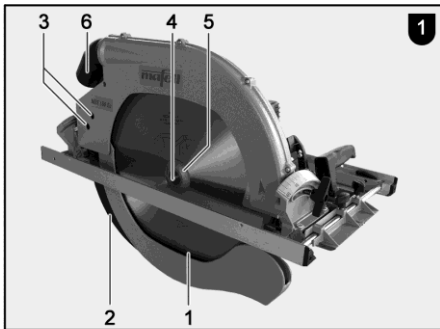

MAF01597/a

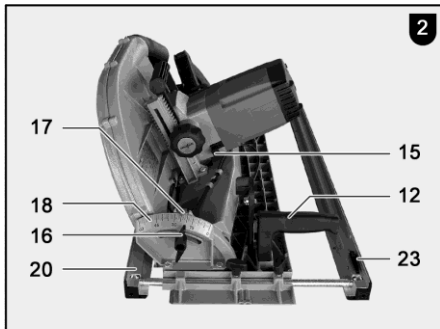

MAF01598/a

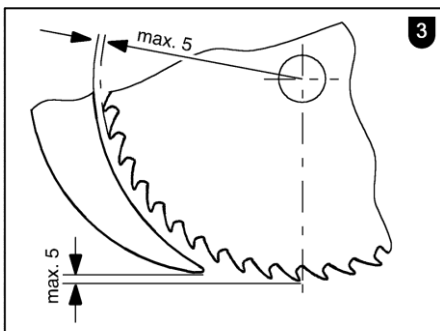

MAF00806/a

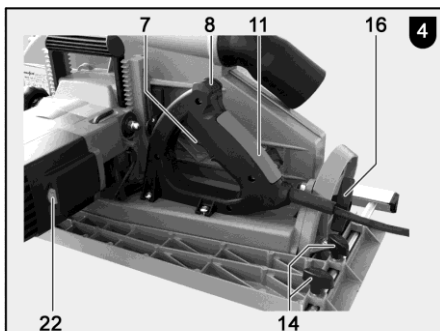

MAF01515/a

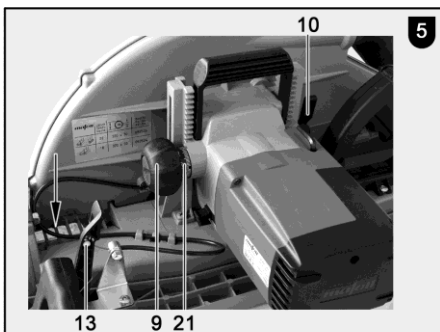

MAF01507/a

D - EG Konformitätserklärung

Wir bescheinigen hiermit, dass die Maschine MKS 130 Ec den angeführten EU-Richtlinien entspricht. Bei Konstruktion und Bau wurden die gelisteten Normen angewendet. Bevollmächtigter für die Zusammenstellung der technischen Unterlagen: Mafell AG

GB - EC Declaration of Conformity

We herewith confirm that the machine MKS 130 Ec complies with the EU directives quoted. The standards listed were used for design and construction. Empowered person for the configuration of the technical documents: Mafell AG

F - Déclaration CE de conformité

Nous déclarons par la présente que la machine MKS 130 Ec est conforme aux directives CE applicables comme suit. Lors de la construction, les règlements suivants ont été utilisés. Plénipotentiaires pour l'assemblage des documentations techniques: Mafell AG

I - Dichiarazione di conformità CE

Con la presente certifichiamo che la macchina MKS 130 Ec è conforme alle seguenti direttive CE applicabili. Nella progettazione e la costruzione sono state applicate le seguenti norme. Responsabile per la composizione della documentazione tecnica: Mafell AG

NL - EG conformiteitsverklaring

Wij bevestigen hiermede dat de machine MKS 130 Ec aan de vermelde EU-richtlijnen beantwoord. Bij constructie en bouw werden de vermelde normen toegepast. Gemachtigde voor de samenstelling van de technische documenten: Mafell AG

E - Declaración de conformidad CE

Con la presente se certifica que la máquina MKS 130 Ec cumple las directivas europeas mencionadas, las cuales forman la base tanto del diseño constructivo como de los procesos de fabricación. Apoderado legal para la compilación de la documentación técnica: Mafell AG

FIN - EY-vaatimustenmukaisuusvakuutus

Vakuutamme täten, että kone MKS 130 Ec vastaa mainittujen EU-direktiivien vaatimuksia. Sen suunnittelussa ja valmistuksessa on sovellettu luettelossa ilmoitettuja standardeja. Teknisten asiakirjojen laatimiseen valtuutettu henkilö: Mafell AG

S - EG Konformitetsförklaring

Vi intyggar härmed att maskinen MKS 130 Ec uppfyller angivna EU direktiv. De angivna normerna användes vid konstruktion och tillverkning. Befullmäktigad för sammanställningen av den tekniska dokumentationen: Mafell AG

DK - EU overensstemmelseserklæring

Vi attesterer hermed, at maskinen MKS 130 Ec opfylder de angivene EU-direktiver. Konstruktion og bygning er udført iht. de angivene standarder. Person, der er befuldmægtiget til at sammenstille det tekniske materiale: Mafell AG

RUS - Сертификат соответствия ЕС

Настоящим подтверждаем, что машина MKS 130 Ec отвечает требованиям указанных директив ЕС. При проектировании и изготовлении применялись перечисленные нормы. Уполномоченный представитель по составлению технической документации: Mafell AG

PL - Deklaracja zgodności UE

Niniejszym potwierdzamy, że maszyna MKS 130 Ec spełnia wymagania wyszczególnionych dyrektyw UE. W trakcie konstrukcji urządzenia zastosowano przedstawione normy. Pełnomocnik odpowiedzialny za zestawienie dokumentacji technicznej: Mafell AG

CZ - PROHLÁŠENÍ O SHODĚ

Tímto prohlašujeme, že stroj MKS 130 Ec splňuje pokyny uvedených směrnic EU. Při plánování a sestavení byly využity uvedené normy. Za sestavení technických podkladů zodpovídá: Mafell AG

SLO - ES izjava o skladnosti

S tem izjavljamo, da stroj MKS 130 Ec ustreza navedenim direktivam EU. Pri konstrukciji in izdelavi so uporabljeni našteti standardi. Za sestavo tehnične dokumentacije je pooblaščen o podjetje: Mafell AG



2006/42/EG
2014/30/EU
2011/65/EU

EN 62841-1, EN62841-2-5, EN 55014-1, EN 55014-2, EN 61000-3, EN 12100, EN 847-1

MKS 130 Ec

Art.-Nr. 925401, 925420, 925421, 925425

Mafell AG

D - 78727 Oberndorf, den 11.06.2019

Dipl.-Ing. Matthias Krauss
Vorstandsvorsitzender / CEO

i. V. Dipl.-Ing. Harald Schmid, MBA
Leitung Entwicklung und Konstruktion

Table of Contents

1	Signs and symbols	19
2	Product information	19
2.1	Manufacturer's data	19
2.2	Machine identification	19
2.3	Technical data	20
2.4	Emissions	20
2.5	Scope of supply	21
2.6	Safety devices	21
2.7	Use according to intended purpose	21
2.8	Residual risks	21
3	Safety instructions	21
4	Setting / Adjustment	24
4.1	Mains connection	24
4.2	Chip extraction	24
4.3	Saw blade selection	24
4.4	Replacing the saw blade	24
4.5	Riving knife / splitter	24
5	Operation.....	25
5.1	Initial operation	25
5.2	Switching on and off	25
5.3	Cutting depth adjustment	25
5.4	Setting for bevel cuts	25
5.5	Sawing according to tracings	25
5.6	Sawing with parallel guide fence	25
6	Service and maintenance	26
6.1	Storage.....	26
7	Troubleshooting.....	26
8	Optional accessories	27
9	Exploded drawing and spare parts list	28

1 Signs and symbols



This symbol appears at places where you will find instructions for your own safety.

Non-compliance with these instructions may result in very serious injuries.



This symbol indicates a potentially hazardous situation.

If this situation is not avoided, the product or objects in its vicinity may get damaged.



This symbol indicates tips for the user and other useful information.

2 Product information

for machines with product no. 925401, 925420, 925421, 925422, 925423 or 925425

2.1 Manufacturer's data

MAFELL AG, Beffendorfer Straße 4, D-78727 Oberndorf / Neckar, Phone +49 (0)7423/812-0, Fax +49 (0)7423/812-218

2.2 Machine identification

All details required for machine identification are available on the attached rating plate.

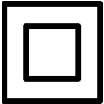

Protection class II



CE symbol to document compliance with the basic safety and health requirements according to Appendix I of the Machinery Directive.



For EU countries only

Do not dispose of electric tools together with household waste material!

In accordance with the European directive 2002/96/EC on waste electrical and electronic equipment and transposition into national law, obsolete electrical tools must be collected separately and recycled in an environmentally-compatible manner.



To reduce the risk of injury, please read the operating instructions.

2.3 Technical data

Universal motor, radio and TV interference suppressed	230 V~, 50 Hz
Power input (nominal load)	2500 W
Current at nominal load	10.8 A
Saw blade speed during idling	1000 - 2000 rpm
Saw blade speed at normal load	890 - 1820 rpm
Cutting depth	50 - 130 mm (2 – 5 1/8 in.)
Maximum cutting depth 30°/45°/60°	115.6/94/65 mm (4 9/16, 3 11/16, 2 9/16 in.)
Tilting saw unit	0 - 60°
Saw blade diameter max/min	330/304 mm (13, 11 7/8 in.)
Saw blade body thickness	2.2 mm (3/32 in.)
Tool cutting width	3.2 mm (1/8 in.)
Saw blade mounting hole	30 mm
Hose connector diameter	58 mm (2 9/32 in.)
Weight without mains cable, with parallel guide fence	12 kg (26.5 lbs)
Dimensions (W x L x H)	345 x 610 x 385 mm (13 19/32 x 24 1/64 x 15 5/32 in.)

2.4 Emissions

The values stated are emission levels. Although there is a correlation between emission and imission level, it cannot be reliably derived from this whether additional precautions are necessary. Factors influencing the current imission level existing at the workplace comprise the duration of exposure, the room characteristic, other sources of noise, etc. such as e.g. the number of machines and other adjacent machining operations. In addition, the permissible imission level may differ from country to country. This information is nevertheless suitable for providing the machine user with an improved assessment of the hazard and risk.

2.4.1 Noise emission specifications

Noise emission values determined according to EN 62841:

Sound pressure level	$L_{PA} = 100 \text{ dB (A)}$
Uncertainty	$K_{PA} = 1,5 \text{ dB (A)}$
Sound power level	$L_{PA} = 111 \text{ dB (A)}$
Uncertainty	$K_{PA} = 1,5 \text{ dB (A)}$

The noise measurement was recorded using the saw blade included in the standard equipment.

2.4.2 Vibration specifications

The typical hand-arm vibration is less than 2.5 m/s².

2.5 Scope of supply

Portable circular saw MKS 130 Ec complete with:

- 1 carbide-tipped circular saw blade Ø 330 mm (13 in.), 24 teeth
- 1 riving knife / splitter (thickness 2.2 mm / 3/32 in.)
- 1 hose connector
- 1 parallel guide fence
- 1 service tool in bracket on the machine
- 1 operating manual
- 1 folder "Safety Instructions"

2.6 Safety devices



Danger

These devices are required for the machine's safe operation and may not be removed or rendered inoperative.

The machine is equipped with the following safety devices:

- Upper stationary saw guard
- Lower retractable saw guard
- Large base plate
- Handles
- Riving knife / splitter
- Index mechanism and brake
- Hose connector

2.7 Use according to intended purpose

The portable circular saw is exclusively suitable for longitudinal and cross cutting of solid wood.

In doing so, the machine must only be used with a horizontal base plate.

This machine must not be used for plunge cuts.

Panel materials such as chip board, core board and medium density fibre board can also be processed. Use approved saw blades according to EN 847-1.

Any other use than described above is not permissible. The manufacturer cannot be held liable for any damage arising from such other use.

So as to use the machine as intended, comply with the operating, maintenance and repair instructions specified by Mafell.

2.8 Residual risks



Danger

Even if used in accordance with its intended purpose and despite conforming with the safety instructions, residual risks caused by the intended use will always remain.

- Touching the saw blade in the vicinity of the starting aperture below the base plate.
- Touching the part of the saw blade that protrudes below the workpiece when cutting.
- Touching of turning parts from the side: saw blade, clamping flange and flange screw.
- Machine backlash if the blade gets stuck in the workpiece.
- Breakage of the saw blade and risk of the blade or pieces of the blade being hurled away.
- Touching live parts with the housing open and the mains plug not removed.
- Hearing can be impaired when working for long periods without ear protectors.
- Emission of harmful wood dusts during longer operation without extraction.

3 Safety instructions



Danger

Always observe the following safety instructions and the safety regulations applicable in the respective country of use!

General instructions:

- Children and adolescents must not operate this machine. This rule does not apply to young persons receiving training and being supervised by an expert.
- Never work without the protection devices prescribed for the respective operating sequence and do not make any changes to the machine that could impair safety.
- When operating the machine outdoors, use of an earth-leakage circuit-breaker is recommended.
- Damaged cables or plugs must be immediately replaced. Replacement may only be carried out by Mafell or an authorised MAFELL service workshop in order to avoid safety hazards.
- Avoid sharp bends in the cable. Especially when transporting and storing the machine, do not wind the cable around the machine.

Do not use:

- Cracked and misshapen saw blades.
- Saw blades made of high speed steel (HSS saw blades).
- Blunt saw blades as they impose an excessive load on the motor.
- Saw blades with a base body with a thickness greater than, or a cutting width (setting) less than, the thickness of the riving knife / splitter.
- Saw blades which are not suitable for the saw blade's idling speed.

Instructions on the use of personal protective equipment:

- Always wear ear protectors during work.
- Always wear a dust mask during work.

Instructions on operation:

Sawing method

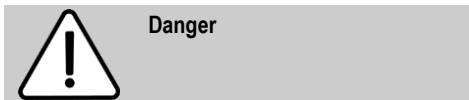

- **Keep hands away from cutting area and the blade. Keep your second hand on auxiliary handle, or motor housing.** If both hands are holding the saw, they cannot be cut by the blade.

- **Do not reach underneath the workpiece.** The guard cannot protect you from the blade below the workpiece.
- **Adjust the cutting depth to the thickness of the workpiece.** Less than a full tooth of the blade teeth should be visible below the workpiece.
- **Never hold the workpiece in your hands or across your leg while cutting. Secure the workpiece to a stable platform.** It is important to support the work properly to minimise body exposure, blade binding, or loss of control.
- **Hold the power tool by insulated gripping surfaces, when performing an operation where the cutting tool may contact hidden wiring or its own cord.** Contact with a "live" wire will also make exposed metal parts of the power tool "live" and could give the operator an electric shock.
- **When ripping, always use a rip fence or straight edge guide.** This improves the accuracy of cut and reduces the chance of blade binding.
- **Always use blades with correct size and shape (diamond versus round) of arbour holes.** Blades that do not match the mounting hardware of the saw will run off-centre, causing loss of control.
- **Never use damaged or incorrect blade washers or bolt.** The blade washers and bolt were specially designed for your saw, for optimum performance and safety of operation.

Kickback causes and related warnings

- kickback is a sudden reaction to a pinched, jammed or misaligned saw blade, causing an uncontrolled saw to lift up and out of the workpiece toward the operator;
- When the blade is pinched or jammed tightly by the kerf closing down, the blade stalls and the motor reaction drives the unit rapidly back toward the operator;
- if the blade becomes twisted or misaligned in the cut, the teeth at the back edge of the blade can dig into the top surface of the wood causing the blade to climb out of the kerf and jump back toward the operator.

Kickback is the result of saw misuse and/or incorrect operating procedures or conditions and can be avoided by taking proper precautions as given below.

- **Maintain a firm grip with both hands on the saw and position your arms to resist kickback forces. Position your body to either side of the blade, but not in line with the blade.** Kickback could cause the saw to jump backwards, but kickback forces can be controlled by the operator, if proper precautions are taken.
- **When blade is binding, or when interrupting a cut for any reason, release the trigger and hold the saw motionless in the material until the blade comes to a complete stop. Never attempt to remove the saw from the work or pull the saw backward while the blade is in motion or kickback may occur.** Investigate and take corrective actions to eliminate the cause of blade binding.
- **When restarting a saw in the workpiece, centre the saw blade in the kerf so that the saw teeth are not engaged into the material.** If a saw blade binds, it may walk up or kickback from the workpiece as the saw is restarted.
- **Support large panels to minimise the risk of blade pinching and kickback.** Large panels tend to sag under their own weight. Supports must be placed under the panel on both sides, near the line of cut and near the edge of the panel.
- **Do not use dull or damaged blades.** Unsharpened or improperly set blades produce narrow kerf causing excessive friction, blade binding and kickback.
- **Blade depth and bevel adjusting locking levers must be tight and secure before making the cut.** If blade adjustment shifts while cutting, it may cause binding and kickback..
- **Use extra caution when sawing into existing walls or other blind areas.** The protruding blade may cut objects that can cause kickback.

Lower guard function

- **Check the lower guard for proper closing before each use. Do not operate the saw if the lower guard does not move freely and close**

instantly. Never clamp or tie the lower guard into the open position. If the saw is accidentally dropped, the lower guard may be bent. Raise the lower guard with the retracting handle and make sure it moves freely and does not touch the blade or any other part, in all angles and depths of cut.

- **Check the operation of the lower guard spring. If the guard and the spring are not operating properly, they must be serviced before use.** Lower guard may operate sluggishly due to damaged parts, gummy deposits, or a build-up of debris.
- **The lower guard may be retracted manually only for special cuts such as "plunge cuts" and "compound cuts". Raise the lower guard by the retracting handle and as soon as the blade enters the material, the lower guard must be released.** For all other sawing, the lower guard should operate automatically.
- **Always observe that the lower guard is covering the blade before placing the saw down on bench or floor.** An unprotected, coasting blade will cause the saw to walk backwards, cutting whatever is in its path. Be aware of the time it takes for the blade to stop after switch is released.

Riving knife function

- **Use the appropriate saw blade for the riving knife.** For the riving knife to function, the body of the blade must be thinner than the riving knife and the cutting width of the blade must be wider than the thickness of the riving knife.
- **Adjust the riving knife as described in this instruction manual.** Incorrect spacing, positioning and alignment can make the riving knife ineffective in preventing kickback.
- **Always use the riving knife except when plunge cutting.** The riving knife must be replaced after plunge cutting. The riving knife causes interference during plunge cutting and can create kickback.
- **For the riving knife to work, it must be engaged in the workpiece.** The riving knife is ineffective in preventing kickback during short cuts.

- **Do not operate the saw if the riving knife is bent** Even a light interference can slow the closing rate of a guard.

Instructions on service and maintenance:

- Regularly cleaning the machine, especially the adjusting devices and guides, constitutes an important safety factor.
- Only original MAFELL spare parts and accessories may be used. Otherwise the manufacturer will not accept any warranty claims and cannot be held liable.

4 Setting / Adjustment

4.1 Mains connection

Prior to commissioning make sure that the mains voltage complies with the operating voltage stated on the machine's rating plate.

4.2 Chip extraction

Connect the machine to a suitable external dust extractor during all work generating a considerable amount of dust. The air velocity must be at least 20 m/s (65.6 ft / sec.).

The inside diameter of hose connector 6 (Fig. 1) is 58 mm (2 9/32 in.).

4.3 Saw blade selection

Use a sharp tool to obtain a good cut quality and select a tool from the following list according to material and application:

For cuts across the grain in soft and hard wood, plywood, chipboard and coreboards:

- TCT circular saw blade Ø 330 x 3.6 x 30 mm (13 x 9/64 in. x 30 mm), 40 teeth

For cuts along the grain in soft and hardwood:

- TCT circular saw blade Ø 330 x 3.2 x 30 mm (13 x 1/8 in. x 30 mm), 24 teeth

For cuts in composite materials:

- TCT circular saw blade Ø 330 x 2.6 x 30 mm (13 x 7/64 in. x 30 mm), 54 teeth, alternate tooth with chamfer

4.4 Replacing the saw blade



Danger

Pull the power plug during all service work.

Proceed as follows to replace the saw blade:

- Press the stop lever 15 (Fig. 2) to lock the saw blade.
- Place the hexagon head socket wrench that is available in a bracket on the machine into the flange screw 4 (Fig. 1) and turn it until the stop lever has engaged completely. Turn the wrench **counter clockwise** to release the flange screw. Remove the screw and the front clamping flange 5. After opening the retractable saw guard 1, you can now remove the saw blade by lifting it to the front and then pulling it in a downward direction.
- Before mounting the new saw blade, both clamping flanges must be checked for adhering parts and cleaned. Pay attention to the sense of rotation when inserting the saw blade. The saw blade teeth must point in the same direction as the arrow on the upper saw guard. Afterwards, mount the clamping flange, attach the flange screw and tighten it by **clockwise** turning. In doing so, the stop lever can be used in the same way as when the screw was released.



Do not press the locking bolt 15 (Fig. 2) with the machine running! The machine may get damaged.

4.5 Riving knife / splitter



Danger

Pull the power plug during all service work.

The riving knife / splitter 2 (Fig. 1) prevents the saw blade from jamming during longitudinal cutting. The correct distance to the saw blade is shown in Fig. 3.

- For adjustment, unfasten the two cylinder-head screws 3 (Fig. 1) with the hexagon head socket wrench supplied, adjust the riving knife / splitter by moving it accordingly in its longitudinal slot and afterwards retighten the two cylinder-head screws.

5 Operation

5.1 Initial operation

Personnel entrusted to work with the machine must be made aware of the operating instructions, calling particular attention to the chapter "Safety instructions".

5.2 Switching on and off

- **Switching on:** First of all, unlock the switch-on lock by pressing the locking lever 8 (Fig. 4). Then, keeping the locking lever depressed, activate the gearshift lever 7.

As this is a switch without locking device, the machine will only run for as long as this gearshift lever is pressed.

The built-in electronic system provides for jerk-free acceleration when the machine is switched on and under load readjusts the speed to the fixed setting.

In addition, this electronic system adjusts the motor down in case of overload, i.e. the saw blade will stop. Switch the machine off then. Then switch the machine on again and continue sawing at a reduced feed speed.

With the setting wheel 22 (Fig. 4) you can steplessly adjust the saw speed between 1000 and 2000 rpm.

- **Switching off:** To switch off, release the switch trigger 7. The built-in automatic brake limits the saw blade slowing time to approx. 5 s. The switch-on lock automatically takes effect again and secures the portable circular saw against accidental switch-on.

5.3 Cutting depth adjustment

The cutting depth is continuously variable between 50 and 130 mm (2 and 5 1/8 in.).

Proceed as follows to adjust it:

- First of all, release the clamping lever 10 (Fig. 5) by turning it counter clockwise.
- You can now adjust the cutting depth by turning the handle 9.
- The set depth can be read off the scale ring 21 (Fig. 5). The inscription on the gearbox case serves as indicator in this regard.



Always set the cutting depth approx. 2 to 5 mm (5/64 to 13/64 in.) larger than the material thickness to be cut.

5.4 Setting for bevel cuts

For bevel cuts, the saw unit can be set to any angle between 0 and 60°.

- Bring the machine into a stable position and support it such that it is possible to tilt the saw unit.
- Then release the two wing screws 16 (Fig. 2 and Fig. 4), tilt the unit to the desired angle shown on the indicator 17 (Fig. 2) on scale 18 at the segment for tilting.
- Afterwards, retighten both wing screws 16 (Fig. 2 and Fig. 4).

5.5 Sawing according to tracings

The base plate is on the inside equipped with a tracing edge that applies both to straight cuts and for all angles of inclination. This tracing edge corresponds to the saw blade's inside. For bevel cuts, the tracing can be viewed through the opening on the left-hand side of the upper saw guard (arrow, Fig. 5).

- For sawing, hold the machine by both its handles 11 (Fig. 4) and 12 (Fig. 2) and place the front part of the base plate onto the workpiece.
- To facilitate the first cut, the retractable saw guard 1 (Fig. 1) can be opened by pressing the lever 13 (Fig. 5) that is arranged directly next to the front handle.

When this lever is released, the saw guard closes automatically.

- Switch on the portable circular saw (see chapter 5.2) and slide the machine evenly forward in the direction of the cut.
- Once you have executed the cut, immediately switch off the saw by releasing the gearshift lever 7 (Fig. 4).

5.6 Sawing with parallel guide fence

The portable circular saw is equipped with a parallel guide fence on both sides, so that it is possible to saw on both sides of the machine parallel to an already

existing edge without retooling. The cutting range on the right-hand side amounts to 140 mm (5 1/2 in.) and on the left-hand side to 320 mm (12 5/8 in.).

- In order to adjust the cutting width, unscrew the wing screws 14 (Fig. 4) and move the guide fence accordingly. Afterwards, retighten the wing screws 14.

In addition, it is possible to turn the guide fence plate 20 (Fig. 2) of the parallel guide fence by 90°. With that it is possible to use the guide fence surface both above and below the base plate. If a straight workpiece edge is already available and if a parallel cut is to be made to this, the guide fence plate 20 is turned down.

If there is no straight workpiece edge, the guide fence plate is turned up to carry out a straight cut.

Now the machine can be guided either along a lathe fastened on the workpiece or along the guide rail that is available as optional accessory.

7 Troubleshooting



Danger

Determining the causes for existing defects and eliminating these always requires increased attention and caution. Pull the mains plug beforehand!

Some of the most frequent defects and their causes are listed in the following chart. In case of other defects, contact your dealer or the MAFELL customer service.

Defect	Cause	Elimination
Machine cannot be switched on	No mains voltage	Check power supply
	Mains fuse defective	Replace fuse
	Carbon brushes worn	Take the machine to a MAFELL customer service shop
Machine stops while cutting is in process	Mains failure	Check mains back-up fuses
	Machine overloaded	Reduce feed speed
Saw blade jams as the machine is advanced	Feed rate too fast	Reduce feed speed
	Blunt saw blade	Release the switch immediately. Remove the machine from the workpiece and replace the saw blade
	Tension in the workpiece	
	Poor machine guidance	Use parallel guide fence
	Uneven workpiece surface	Straighten the surface

6 Service and maintenance



Danger

Pull the power plug during all service work.

MAFELL machines are designed to be low in maintenance.

The ball bearings used are greased for life. When the machine has been in operation for a longer period of time, we recommend to hand the machine in at an authorised MAFELL customer service shop for inspection.

Only use our special grease, order No. 049040 (1 kg tin) for all greasing points.

6.1 Storage

If the machine is not used for a longer period of time, it has to be carefully cleaned. Spray bright metal parts with a rust inhibitor.

Defect	Cause	Elimination
Burn marks on the cut surfaces	The saw blade used is unsuitable for the task or blunt	Replace saw blade
Chip ejection blocked	Wood is too damp	
	Extended operation without exhaust	Connect to an external exhaust, e.g. portable dust extractor

8 Optional accessories

- Guide rail, one-piece complete 3 m (9.85 ft) long Order No. 200672
- Guide rail, two-piece complete 3 m (9.85 ft) long Order No. 037037
- Guide rail – extension 1,5 m (4.9 ft) long Order No. 036553
- Pair of adapters for parallel stop for hooking into the guide rail Order No. 037195
- Saw blade TCT Ø 330 x 3.6 x 30 mm (13 x 9/64 in. x 30 mm), 40 teeth (cross cuts) Order No. 092572
- Saw blade TCT Ø 330 x 3.2 x 30 mm (13 x 1/8 in. x 30 mm), 24 teeth (longitudinal and cross cuts) Order No. 092571
- Saw blade TCT Ø 330 x 2.6 x 30 mm (13 x 7/64 in. x 30 mm), 54 teeth (composite materials) Order No. 092579
- Guide rail F80, 800 mm (2.6 ft) long Order No. 204380
- Guide rail F110, 1100 mm (3.6 ft) long Order No. 204381
- Guide rail F160, 1600 mm (5.25 ft) long Order No. 204365
- Guide rail F210, 2100 mm (6.9 ft) long Order No. 204382
- Guide rail F310, 3100 mm (10.2 ft) long Order No. 204383
- Sliding bevel segment F-WA Order No. 205357
- Accessories for guide rail:
 - Screw clamp F-SZ100MM (2 Qty.) Order No. 205399
 - Connecting piece F-VS Order No. 204363
 - Rail bag F160 Order No. 204626
- Rail bag kit F80/160 consisting of: F80 + F160 + connecting piece + 2screw clamps + rail bag Order No. 204748
- Rail bag kit F80/160 with sliding bevel segment consisting of: F80 + F160+ connecting piece + sliding bevel segment + 2 screw clamps + rail bag Order No. 204749
- Rail bag kit F160/160 consisting of: 2 x F160 + connecting piece + 2screw clamps + rail bag Order No. 204805



Safety instruction for use of the MKS 130 Ec on already supplied guide rails of the following types:

FS 140

Order No.: 202870

FS 300

Order No.: 202869

FSX

Order No.: 203802

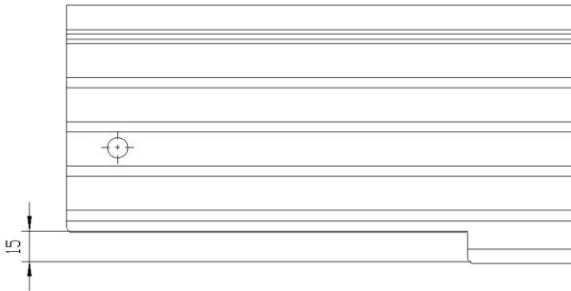

To ensure that the movable protection hood functions properly when being opened and closed on the guide rail, the cut-out at the start end has to be large enough.

Please verify that the dimension is 15 mm. (Refer to sketch)

If the dimension is smaller than 15 mm, the cut-out at the start end of the guide rail has to be broadened to 15 mm.

Since the guide rail is made of aluminium, this can be done by means of a saw.

9 Exploded drawing and spare parts list

The corresponding information in respect of spare parts can be found on our homepage: www.mafell.com