

de	Originalbetriebsanleitung - Tauchsäge	8
en	Original Instructions - Plunge-cut saw	20
fr	Notice d'utilisation d'origine- Scie plongeante	31
es	Manual de instrucciones original - Sierra de incisión	44
it	Istruzioni per l'uso originali - Sega ad affondamento	57
nl	Originele gebruiksaanwijzing - Inval-cirkelzaagmachine	69
sv	Originele gebruiksaanwijzing - Inval-cirkelzaagmachine	81
fi	Alkuperäiset käyttöohjeet - Upotussaha	92
da	Original brugsanvisning - Dyksav	103
nb	Originalbruksanvisning - Dykksag	114
pt	Manual de instruções original - Serra de incisão	125
ru	Оригинальное руководство по эксплуатации - Погружная пила	138
cs	Originál návodu k obsluze - Ponorná pila	151
pl	Oryginalna instrukcja eksploatacji - Zagłębiarka	162

TS 60 KEBQ

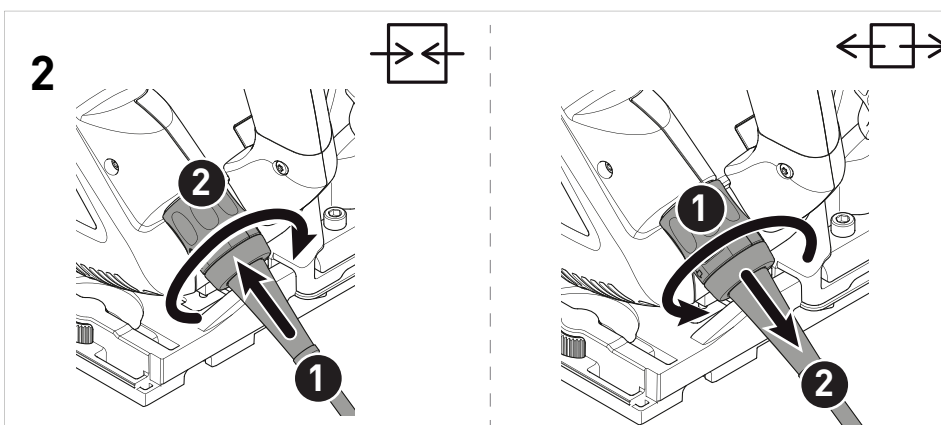

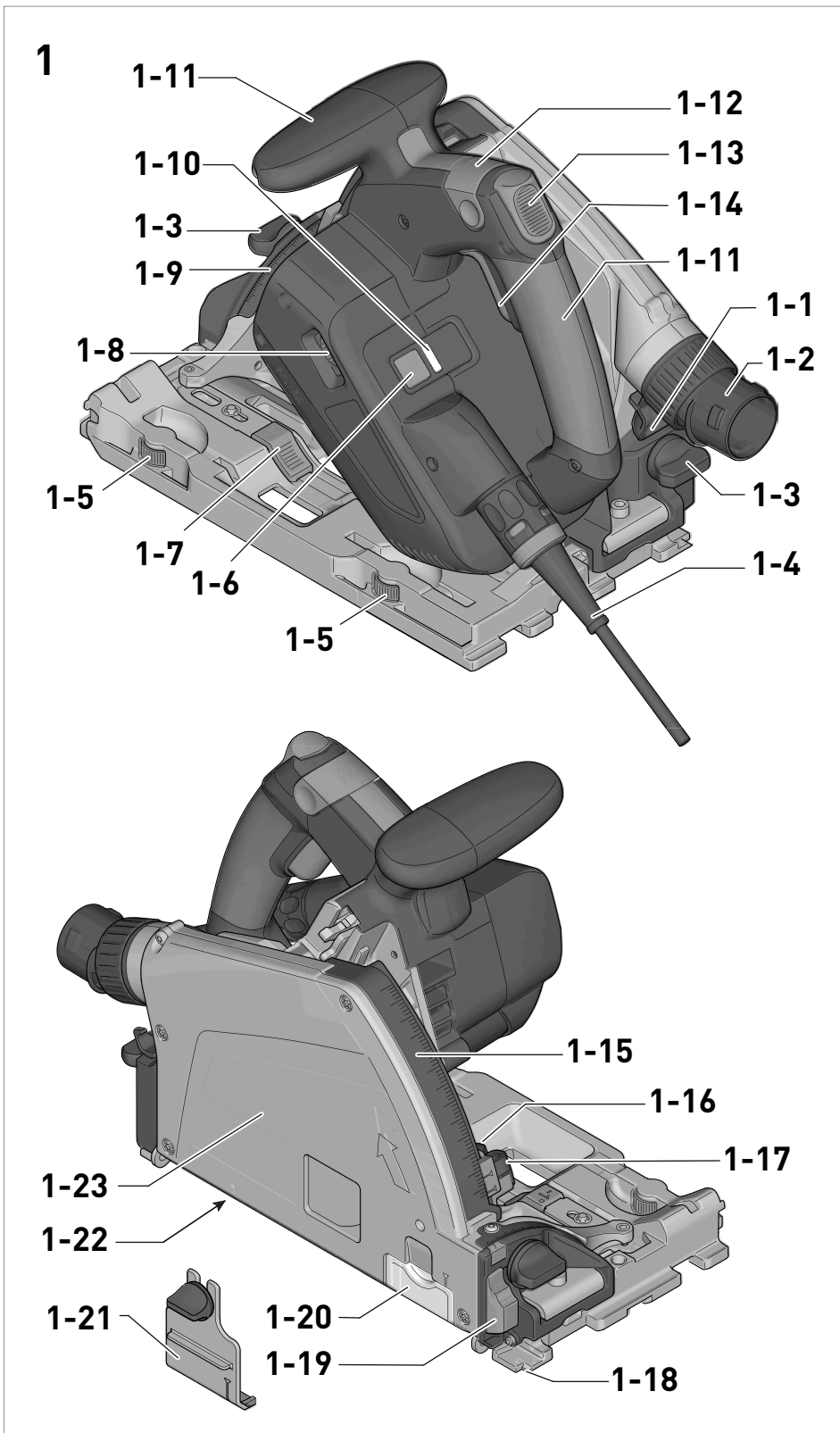

3

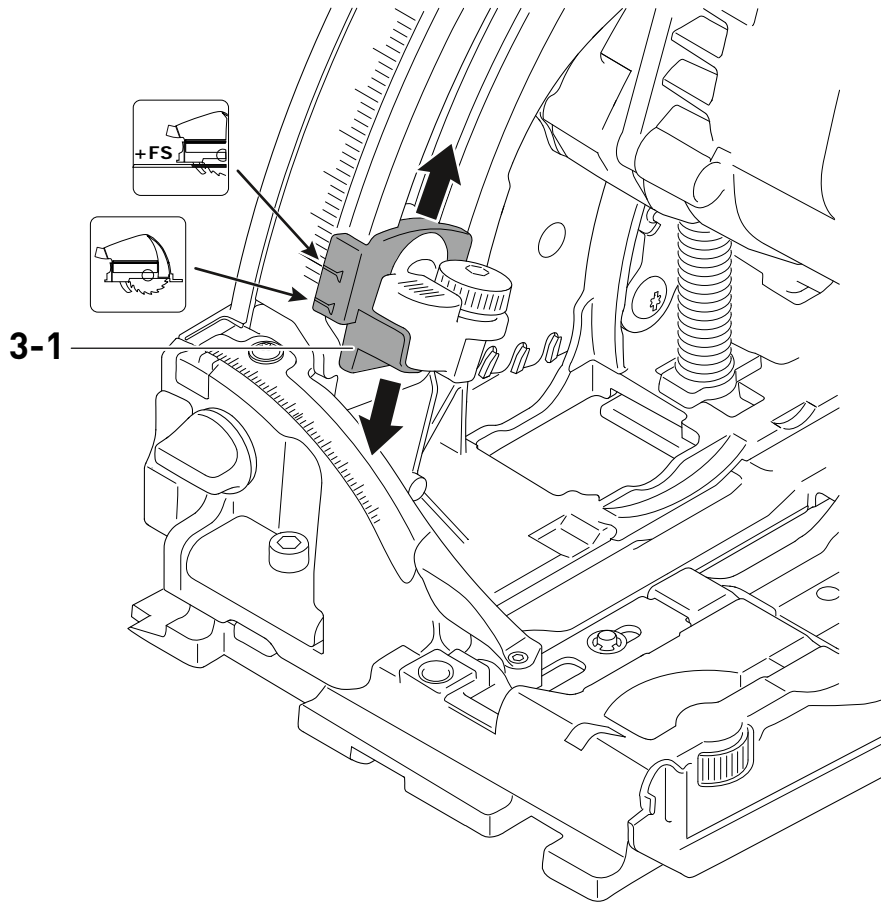

4

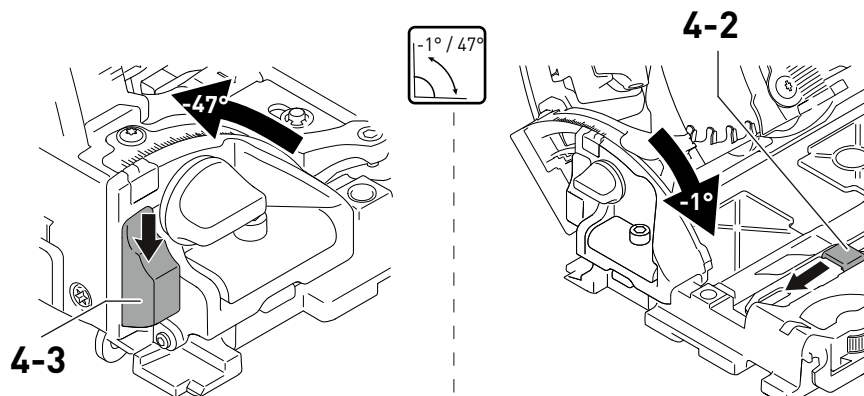
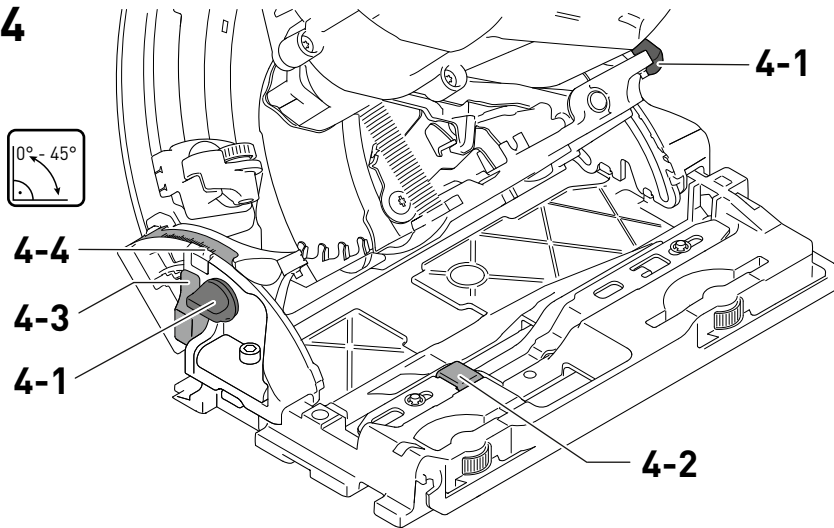

5

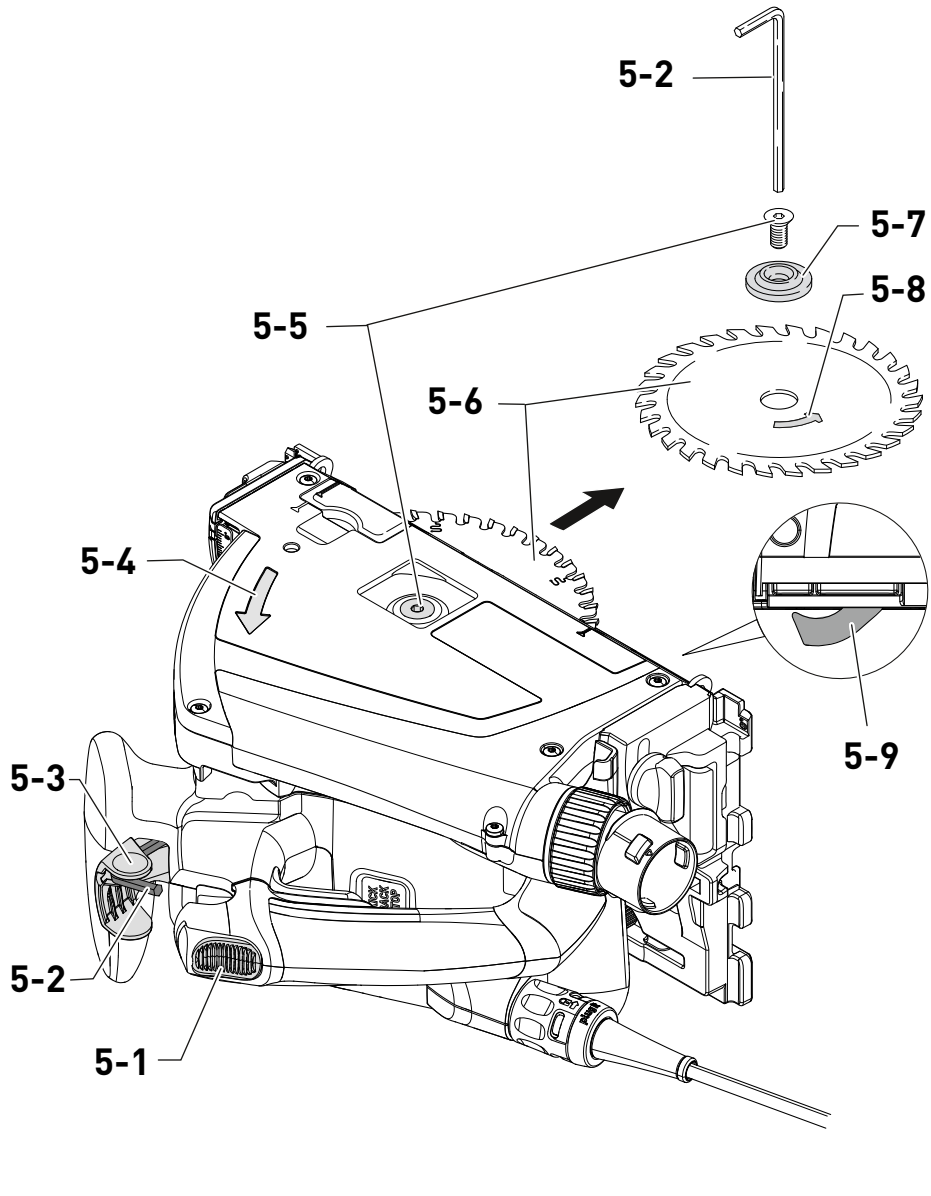

6

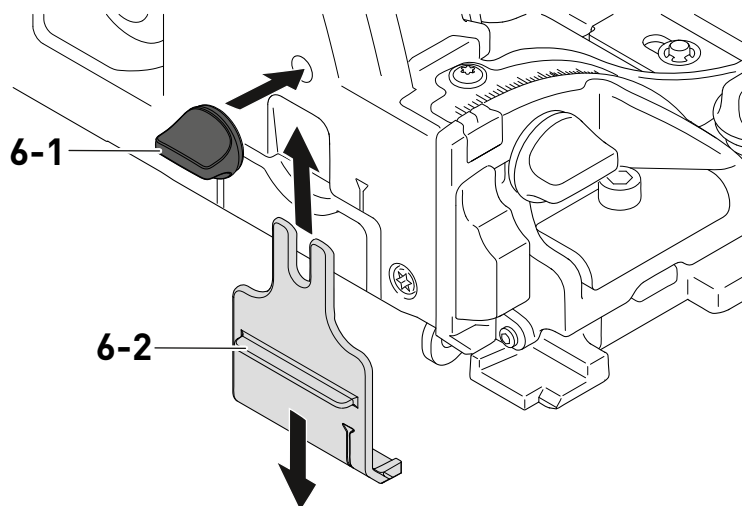

7

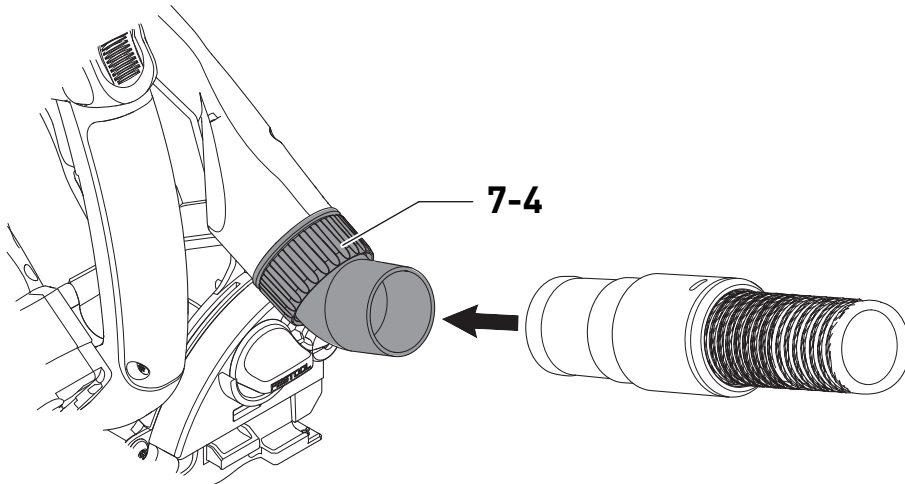
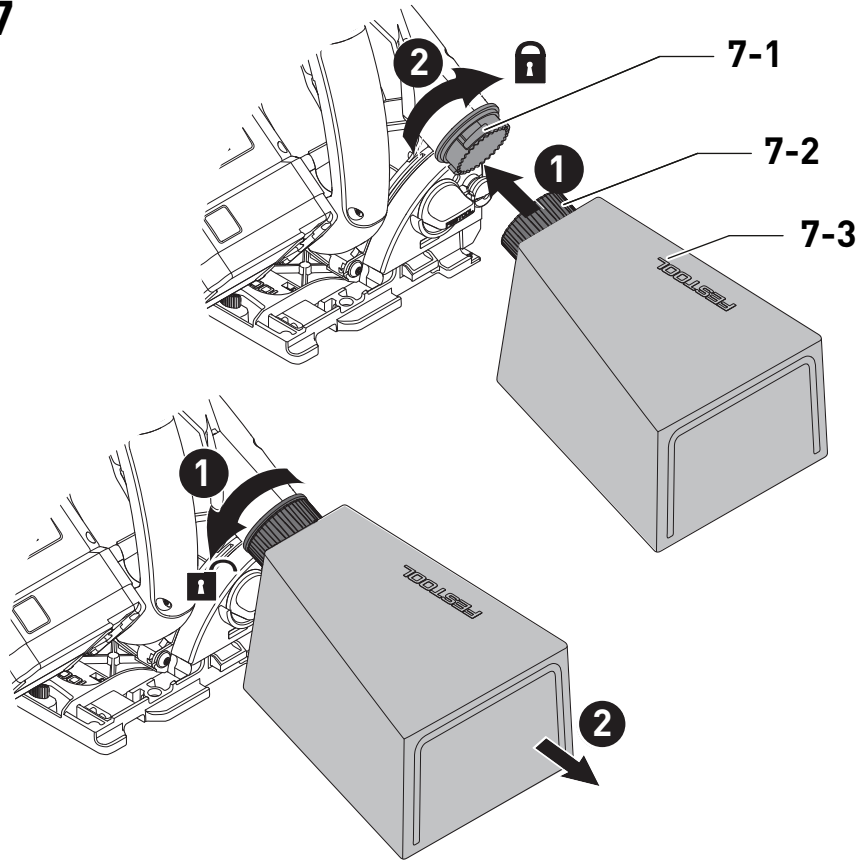

8A

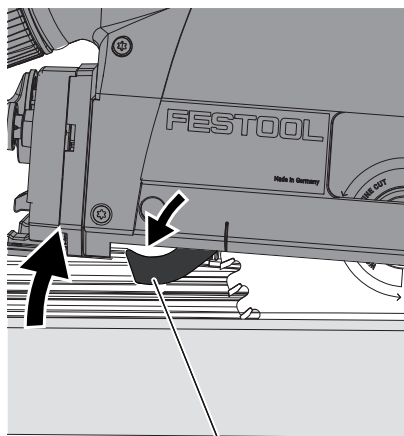

8B

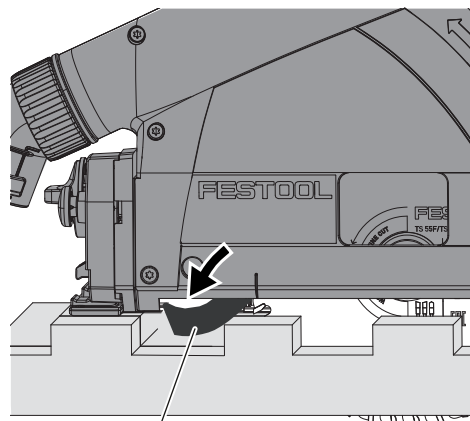

We as the manufacturer declare under our sole responsibility that the product(s) fulfill(s) all the relevant provisions of the following UK Regulations and are manufactured in accordance with the following designated standards:

S.I. 2008/1597	Supply of Machinery [Safety] Regulations 2008
S.I. 2016/1091	Electromagnetic Compatibility Regulations 2016
S.I. 2012/3032	Restriction of the Use of Certain Hazardous Substances in Electrical and Electronic Equipment Regulations 2012

BS EN 62841-1:2015
BS EN 62841-2-5:2014
BS EN 55014-1:2017 + A11:2020
BS EN 55014-2:2015
BS EN IEC 61000-3-2:2019
BS EN 61000-3-3:2013 + A2:2021
BS EN IEC 63000:2018



Signed on behalf of and in name of
Festool GmbH
Wertstr. 20, 73240 Wendlingen, GERMANY

Place and date of declaration: Wendlingen, 2022-07-01

Markus Stark
Head of Product Development

Christian Bader
Head of Development Functions

¹⁾ in the specified serial number range (S-Nr.) from 40000000 - 49999999

Tauchsäge
Plunge-cut saw
Scie plongeante

Seriennummer *
Serial number *
N° de série *
(T-Nr.)

TS 60 KEBQ

10036595

de EU-Konformitätserklärung. Wir erklären in alleiniger Verantwortung, dass dieses Produkt mit allen relevanten Anforderungen folgender EU-Richtlinien übereinstimmt, und folgende Normen oder normative Dokumente zugrunde gelegt wurden:

en EU Declaration of Conformity. We declare under sole responsibility that this product complies with all the relevant requirements in the following EU Directives, and following standards and normative documents were applied:

fr Déclaration de conformité de l'UE. Nous déclarons, sous notre seule responsabilité, que ce produit satisfait à toutes les exigences pertinentes des directives UE suivantes et repose sur les normes ou documents normatifs suivants :

es Declaración UE de conformidad. Declaramos bajo nuestra responsabilidad que este producto cumple todos los requisitos relevantes de las siguientes directivas de la UE y que se han tomado como base las siguientes normas o documentos normativos:

it Dichiarazione di conformità UE. Dichiariamo sotto nostra unica responsabilità che il presente prodotto sia conforme a tutti i requisiti di rilevanza definiti dalle seguenti Direttive UE e che siano stati applicati le seguenti norme o i seguenti documenti normativi:

nl EU-conformiteitsverklaring. Wij verklaren en stellen ons ervoor verantwoordelijk dat dit product volledig voldoet aan alle volgende EU-richtlijnen en volgende normen of normatieve documenten daaraan ten grondslag gelegd werden:

sv EU-försäkran om överensstämmelse. Vi förklarar på eget ansvar att denna produkt uppfyller alla relevanta krav enligt följande EU-direktiv och baseras på följande normer eller normgivande dokument:

fi EU-vaatimustenmukaisuusvakuutus. Vakuutamme yksinomaisella vastuulla, että tämä tuote täyttää seuraavien EU-direktiivien kaikki olennaiset vaatimukset ja se on seuraavien standardien tai standardiasiakirjojen mukainen:

da EU-overensstemmelseserklæring. Vi erklærer med eneansvar, at dette produkt er i overensstemmelse med alle relevante krav i følgende EU-direktiver, og at følgende standarder eller normative dokumenter danner grundlag for det:

nb EU-samsvarserklæring. Vi erklærer under eneansvar at dette produktet oppfyller alle relevante krav i følgende EU-direktiver og at følgende standarder eller normative dokumenter er blitt lagt til grunn:

pt Declaração de conformidade UE. Sob nossa inteira responsabilidade, declaramos que este produto está de acordo com todas as exigências relevantes das seguintes diretivas UE, tendo sido tomadas por base as seguintes normas ou documentos normativos:

ru Декларация о соответствии ЕС. Мы со всей ответственностью заявляем, что данная продукция соответствует всем применимым требованиям следующих Директив ЕС, стандартов и нормативных документов:

cs Prohlášení o shodě EU. Prohlašujeme s veškerou odpovědností, že tento výrobek splňuje všechny příslušné požadavky následujících směrnic EU a že byly použity následující normy nebo normativní dokumenty:

pl Deklaracja zgodności UE. Niniejszym oświadczamy na własną odpowiedzialność, że produkt ten spełnia wszystkie obowiązujące wymagania następujących dyrektyw UE, norm lub dokumentów normatywnych.

2006/42/EC, 2014/30/EU, 2011/65/EU

EN 62841-1:2015 + AC:2015

EN 62841-2-5:2014

EN 55014-1:2017 + A11:2020

EN 55014-2:2015

EN IEC 61000-3-2:2019

EN 61000-3-3: 2013 + A1:2019

EN IEC 63000:2018



Unterzeichnet für und im Namen von/
Signed on behalf of and in name of/
Signé pour et au nom de

Festool GmbH

Wertstr. 20, 73240 Wendlingen, GERMANY

Wendlingen, 2022-07-01

Markus Stark

Head of Product Development

Christian Bader

Head of Development Functions

* im definierten Seriennummer-Bereich (S-Nr.) von 40000000 - 49999999















in the specified serial number range (S-Nr.) from 40000000 - 49999999

dans la plage de numéro de série (S-Nr.) de 40000000 - 49999999

Contents

1	Symbols.....	20
2	Safety warnings.....	20
3	Intended use.....	23
4	Technical data.....	23
5	Parts of the device.....	24
6	Commissioning.....	24
7	Settings.....	24
8	Working with the electric power tool.....	26
9	Service and maintenance.....	29
10	Accessories.....	30
11	Environment.....	30
12	General information.....	30

1 Symbols

-  Warning of general danger
-  Warning of electric shock
-  Read the operating instructions and safety instructions.
-  Wear ear protection.
-  Wear protective gloves when changing tools!
-  Wear a dust mask.
-  Wear protective goggles.
-  Pull out the mains plug
-  Disconnecting the mains power cable
-  Connecting the mains power cable
-  Direction of rotation of saw and the saw blade
-  KickbackStop function
-  Do not dispose of it with domestic waste.
-  Tool contains a chip which stores data. See section [12.1](#)
-  CE marking: Confirms the conformity of the power tool with the European Community directives.



UKCA marking: The United Kingdom Conformity Assessed symbol is a marking for products being placed on the market in the United Kingdom. It is a manufacturers indication that the product is in conformance with the relevant regulations in the UK.

▶ Handling instruction

 Tip or advice

 Safety class II

2 Safety warnings

2.1 General power tool safety warnings

 **WARNING! Read all safety warnings, instructions, illustrations and specifications provided with this power tool.** Failure to follow all instructions listed below may result in electric shock, fire and/or serious injury.

Save all warnings and instructions for future reference.

The term "power tool" in the warnings refers to your mains-operated (corded) power tool or battery-operated (cordless) power tool.

2.2 Safety instructions for specific circular saws

- **Only for AS/NZS:** The tool shall always be supplied via residual current device with a rated residual current of 30 mA or less.

Cutting procedures

-  **DANGER: Keep hands away from cutting area and the blade. Keep your second hand on auxiliary handle, or motor housing.** If both hands are holding the saw, they cannot be cut by the blade.
- **Do not reach underneath the workpiece.** The guard cannot protect you from the blade below the workpiece.
- **Adjust the cutting depth to the thickness of the workpiece.** Less than a full tooth of the blade teeth should be visible below the workpiece.
- **Never hold the workpiece in your hands or across your leg while cutting. Secure the workpiece to a stable platform.** It is important to support the work properly to minimise body exposure, blade binding, or loss of control.

- **Hold the power tool by the insulated handle surfaces if you intend to perform work that entails a risk of cutting into hidden power cables or the tool's own power cable.** Contact with live cables transfers an electric current to metal components on the electric power tool and causes electric shocks.
- **When ripping, always use a rip fence or straight edge guide.** This improves the accuracy of cut and reduces the chance of blade binding.
- **Always use blades with correct size and shape (diamond versus round) of arbour holes.** Blades that do not match the mounting hardware of the saw will run off-centre, causing loss of control.
- **Never use damaged or incorrect blade washers or bolt.** The blade washers and bolt were specially designed for your saw, for optimum performance and safety of operation.

Kickback causes and related warnings

- kickback is a sudden reaction to a pinched, jammed or misaligned saw blade, causing an uncontrolled saw to lift up and out of the workpiece toward the operator;
- when the blade is pinched or jammed tightly by the kerf closing down, the blade stalls and the motor reaction drives the unit rapidly back toward the operator;
- if the blade becomes twisted or misaligned in the cut, the teeth at the back edge of the blade can dig into the top surface of the wood causing the blade to climb out of the kerf and jump back toward the operator.

Kickback is the result of saw misuse and/or incorrect operating procedures or conditions and can be avoided by taking proper precautions as given below.

- **Maintain a firm grip with both hands on the saw and position your arms to resist kickback forces. Position your body to either side of the blade, but not in line with the blade.** Kickback could cause the saw to jump backwards, but kickback forces can be controlled by the operator, if proper precautions are taken.
- **When blade is binding, or when interrupting a cut for any reason, release the trigger and hold the saw motionless in the material until the blade comes to a complete stop. Never attempt to remove the saw from the work or pull the saw back-**

ward while the blade is in motion or kickback may occur. Investigate and take corrective actions to eliminate the cause of blade binding.

- **When restarting a saw in the workpiece, centre the saw blade in the kerf so that the saw teeth are not engaged into the material.** If a saw blade binds, it may walk up or kickback from the workpiece as the saw is restarted.
- **Support large panels to minimise the risk of blade pinching and kickback.** Large panels tend to sag under their own weight. Supports must be placed under the panel on both sides, near the line of cut and near the edge of the panel.
- **Do not use dull or damaged blades.** Unsharpened or improperly set blades produce narrow kerf causing excessive friction, blade binding and kickback.
- **Blade depth and bevel adjusting locking levers must be tight and secure before making the cut.** If blade adjustment shifts while cutting, it may cause binding and kickback.
- **Use extra caution when sawing into existing walls or other blind areas.** The protruding blade may cut objects that can cause kickback.

Guard function

- **Check the lower guard for proper closing before each use. Do not operate the saw if the lower guard does not move freely and close instantly. Never clamp or tie the lower guard into the open position.** If the saw is accidentally dropped, the lower guard may be bent. Raise the lower guard with the retracting handle and make sure it moves freely and does not touch the blade or any other part, in all angles and depths of cut.
- **Check the operation and condition of the guard return spring. If the guard and the spring are not operating properly, they must be serviced before use.** The guard may operate sluggishly due to damaged parts, gummy deposits, or a build-up of debris.
- **Assure that the base plate of the saw will not shift while performing a "plunge cut".** Blade shifting sideways will cause binding and likely kick back.

- **Always observe that the guard is covering the blade before placing the saw down on bench or floor.** An unprotected, coasting blade will cause the saw to walk backwards, cutting whatever is in its path. Be aware of the time it takes for the blade to stop after the switch is released.

Function of the feeler wedge [1-22] (Kickback-Stop function)

- **Every time the saw blade is replaced, clean the feeler unit [5-9] by blowing it out or using a brush.** Any contamination of the feeler unit may impair the KickbackStop function and therefore prevent the saw blade from being stopped.
- **Do not operate the saw if the feeler wedge is bent.** Even the slightest damage can slow the braking of the saw blade.

2.3 Safety instructions for the pre-assembled saw blade

Usage

- The maximum speed specified on the saw blade must not be exceeded and the speed range must be adhered to.
- The pre-installed saw blade is only designed for use in circular saws.
- Proceed with extreme care when unpacking, packing and handling the tool (e.g. installing it in the machine). There is a risk of injury from extremely sharp cutting edges!
- When handling the tool, wearing safety gloves provides a more secure hold of the tool and further reduces the risk of injury.
- Circular saw blades with cracked bodies must be replaced. Repair is not permitted.
- Circular saw blades with a combination design (soldered saw teeth) with saw tooth thickness smaller than 1 mm must no longer be used.
- **WARNING!** Do not use tools with visible cracks or blunt or damaged cutting edges.

Installation and mounting

- Tools must be clamped in such a way that they cannot come loose during operation.
- When assembling the tools, it must be ensured that the clamping takes place on the tool hub or the clamping surface of the tool, and that the cutting edges do not come into contact with other components.
- Do not lengthen the key or tighten by hitting with a hammer.

- The clamping surfaces must be cleaned to remove contamination, grease, oil and water.
- Clamping screws must be tightened according to the manufacturer's instructions.
- Only securely installed rings, e.g. rings that have been pressed in or those that are held in position by an adhesive bond, may be used to adjust the hole diameter of circular saw blades to the spindle diameter of the machine. The use of loose rings is not permitted.

Service and maintenance

- Repairs and sanding work may only be carried out by Festool customer service workshops or experts.
- The tool design must not be changed.
- Deresinify and clean the tool regularly (cleaning agent with pH between 4.5 and 8).
- Blunt edges can be resharpened on the clamping surface to a minimum cutting edge thickness of 1 mm.
- Only transport the tool in suitable packaging – risk of injury!

2.4 Further safety instructions



- **Wear suitable personal protective equipment:** Ear protection, safety goggles, a dust mask for work that generates dust.
- **Harmful/toxic dust may be produced during your work (e.g. paint containing lead, certain types of wood or metals).** Contact with or inhalation of this dust may pose a risk for the operating personnel or persons in the vicinity. Comply with the safety regulations that apply in your country.
-  Wear a P2 respiratory mask to protect your health. In enclosed spaces, ensure that there is sufficient ventilation and connect a mobile dust extractor.
- **This power tool cannot be installed in a work bench.** The power tool may become unsafe and cause serious accidents if installed in benches from other manufacturers or self-manufactured work benches.
- Check whether there are any signs of damage to the housing components, such as cracks or stress whitening. Have any damaged components repaired before using the power tool.

- **Use appropriate detection devices to look for any hidden supply lines or consult your local utility company.** If the insertion tool makes contact with live cables, it can result in fire and electric shock. Damage to a gas pipe can lead to an explosion. Penetration of a water pipe can result in damage to property.

2.5 Sawing aluminium

When sawing aluminium, the following measures must be taken for safety reasons:

-  Wear protective goggles.
- Regularly clean dust deposits from the motor housing on the power tool.
- Use an aluminium saw blade.
- Close the viewing window/chip guard.
- Install an upstream residual-current circuit breaker (RCD, PRCD).
- When sawing panels, they must be lubricated with petroleum, but thin-walled profiles (up to 3 mm) can be sawed without lubrication.

2.6 Emission levels

The levels determined in accordance with EN 62841 are typically:

Sound pressure level	$L_{PA} = 91 \text{ dB(A)}$
Sound power level	$L_{WA} = 102 \text{ dB(A)}$
Uncertainty	$K = 3 \text{ dB}$



CAUTION

Noise generated when working
Risk of damage to hearing

- Use ear protection.

Vibration emission level a_h (vector sum for three directions) and uncertainty K measured in accordance with EN 62841:

Sawing wood	$a_h < 2.5 \text{ m/s}^2$ $K = 1.5 \text{ m/s}^2$
Sawing metal	$a_h < 2.5 \text{ m/s}^2$ $K = 1.5 \text{ m/s}^2$

The specified emission levels (vibration, noise)

- are used to compare machines.
- They are also used for making preliminary estimates regarding vibration and noise load during operation.

- They represent the primary applications of the power tool.



CAUTION

The emission values may deviate from the specified values. This is dependent on how the tool is used and the type of workpiece being machined.

- The actual load during the entire operating cycle must be evaluated.
- Depending on the actual load, suitable protective measures must be defined in order to protect the operator.

3 Intended use

Plunge-cut saws are designed for sawing wood, materials similar to wood, gypsum and cement-bonded fibre materials and plastics.

When fitted with the special saw blades offered by Festool, the machines can also be used for sawing unhardened ferrous metal and non-ferrous metal.

Materials containing asbestos must NOT be processed.

Do not use cutting or abrasive wheels.



The user is liable for improper or non-intended use.

3.1 Saw blades

Only use saw blades with the following dimensions:

- Saw blades according to EN 847-1
- Saw blade diameter 168 mm
- Cutting width 1.8 mm
- Locating bore 20 mm
- Standard blade thickness 1.2 mm
- Suitable for speeds of up to 9500 rpm

Festool saw blades comply with EN 847-1.

Only saw materials for which the saw blade in question has been designed.

4 Technical data

Circular saw	TS 60 KEBQ	TS 60 KEB
Removable mains power cable (plug-it)	✓	×
Power	1.500 W	
Speed	3.000 - 6.800 rpm	
Max. speed (no-load)	6.800 rpm	

Circular saw	TS 60 KEBQ TS 60 KEB
Inclination	-1° to 47°
Cutting depth at 0°	0 - 62 mm
Cutting depth at 45°	0 - 45 mm
Saw blade dimensions	168x1.8x20 mm
Weight as per EPTA procedure 01:2014 (without power cable)	4.6 kg

5 Parts of the device

- [1-1]** Cable routing
- [1-2]** Extractor connector
- [1-3]** Rotary knobs for adjusting the angle
- [1-4]** Mains power cable
- [1-5]** Adjustable jaws
- [1-6]** KickbackStop function OFF button
- [1-7]** Slide for undercuts -1°
- [1-8]** Speed control
- [1-9]** Angle scale
- [1-10]** KickbackStop function status LED
- [1-11]** Handles
- [1-12]** Lever for changing the tool
- [1-13]** Safety lock
- [1-14]** On/off switch
- [1-15]** Split scale for the cutting depth stop (with/without a guide rail)
- [1-16]** Cutting depth adjusting screw for re-conditioned saw blades
- [1-17]** Cutting depth stop
- [1-18]** Gauge marker
- [1-19]** Slide for undercuts 47°
- [1-20]** Viewing window/chip guard
- [1-21]** Splinter guard
- [1-22]** Feeler wedge
- [1-23]** Protective lid

The specified illustrations appear at the beginning of the Operating Instructions.

Accessories shown or described are not always included in the scope of delivery.

6 Commissioning



WARNING

Unauthorised voltage or frequency.

Risk of accidents

- ▶ The mains voltage and the frequency of the power source must correspond to the specifications on the name plate.
- ▶ In North America, only Festool machines with the voltage specifications 120 V / 60 Hz may be used.



Always switch off the machine before connecting and disconnecting the mains power cable.

6.1 Machines with plug-it connection

Applies to TS 60 KEBQ.



CAUTION

Heating of the plug it connection if bayonet fitting is not completely locked

Risk of burns

- ▶ Before switching on the power tool, make sure that the bayonet fitting at the mains cable is closed fully and locked.

Connecting and detaching the mains power cable **[1-4]** see Fig. **[2]**.

7 Settings



WARNING

Risk of injury, electric shock

- ▶ Always disconnect the mains plug from the socket before performing any work on the machine.

7.1 Electronics

Speed control

You can continuously adjust the speed within the speed range using the adjusting wheel **[1-8]** (see "Technical data"). This enables you to optimise the cutting speed to suit each surface.

Speed range per material

Solid wood (hard, soft)	6
Chipboard and hardboard	3-6
Laminated wood, blockboard, veneered and laminated panels	6
Laminate, mineral materials	4-6

Speed range per material

Plaster- and cement-bonded chipboard and fibreboard	1-3
Aluminium panels and profiles up to 15 mm	4-6
Plastics, fibre-reinforced plastics, paper and fabric	3-5
Acrylic glass	4-5

Overload protection

Electronic overload protection protects the motor from damage if there is an extreme overload. In this case, the motor remains at a standstill and only starts up again once the load has been removed. To restart the machine, you must switch it on again.

Brake

The saw comes with an electronic brake. The saw blade is stopped electronically within approximately two seconds of switching off the machine.

Temperature cut-out

The power supply is restricted and the speed reduced if the motor exceeds a certain temperature. The power tool continues operating at reduced power to allow the ventilator to cool the motor quickly. The power tool starts up again automatically once the motor has cooled sufficiently.

7.2 Adjusting the cutting depth

The cutting depth can be set at 0 - 62 mm at the cutting depth stop [3-1].

The saw unit can now be pushed downwards as far as the cutting depth that is set.

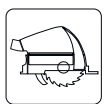

Cutting depth without guide rail
max. 62 mm



Cutting depth with FS guide rail
max. 57 mm

7.3 Adjusting the cutting angle

Between 0° and 45°

- ▶ Open the rotary knobs [4-1].
- ▶ Swivel the saw unit to the desired cutting angle [4-4].
- ▶ Close the rotary knobs [4-1].

i Both positions (0° and 45°) are set at the factory and can be readjusted by the customer service team.



When making angled cuts, slide the viewing window/splinter guard to the highest position.

To undercut -1° and 47°

- ▶ Swivel the saw unit to the end position (0°/45°) as described above.
- ▶ For 47° undercuts, push the slide [4-3] on the front swivelling segment downwards.
- ▶ For -1° undercuts, push the slide [4-2] on the plate forwards.

The saw unit engages in the -1°/47° position.

- ▶ Close the rotary knobs [4-1].

7.4 Selecting the saw blade

Festool saw blades are identified by a coloured ring. The colour of the ring represents the material for which the saw blade is suited.

Refer to the necessary saw blade data (see section 3.1).

Colour	Material	Symbol
Yellow	Wood	
Red	Laminate, mineral material	
Green	Plaster- and cement-bonded chipboard and fibreboard	
Blue	Aluminium, plastic	

7.5 Changing the saw blade [5]



WARNING

Risk of injury, electric shock

- ▶ Always disconnect the mains plug from the socket before performing any work on the machine.



CAUTION

Risk of injury from hot and sharp insertion tool

- ▶ Do not use any blunt or faulty insertion tools.
- ▶ Wear protective gloves when handling an insertion tool.

Removing the saw blade

- ▶ Swivel the saw to 0° before replacing the saw blade and adjust the maximum cutting depth.

- ▶ Turn the lever **[5-3]** as far as it will go. Operate the lever **only when the saw is at a standstill!**
- ▶ Push the saw unit down until it engages.
- ▶ Lay the saw on its side on a stable base. Saw blade side upwards.
- ▶ Loosen the screw **[5-5]** using the Allen key **[5-2]**.
- ▶ Remove the saw blade **[5-6]**.

Cleaning the feeler unit

WARNING! Any contamination of the feeler unit may impair the KickbackStop function and therefore prevent the saw blade from being stopped.

- ▶ Hold the saw unit securely by its handle, close the lever **[5-3]** and press the saw unit all the way down.
- ▶ Release the lever **[5-3]** again and click the saw unit into place.
- ▶ Clean the feeler unit **[5-9]** by blowing it out or using a brush.

Inserting the saw blade

WARNING! Check the screws and flange for contamination and only use clean and undamaged parts.

- ▶ Hold the saw unit securely by its handle and turn the lever **[5-3]** as far as it will go.
- ▶ Push the saw unit down until it engages.
- ▶ Insert a new saw blade.

WARNING! The direction of rotation of the saw blade **[5-8]** and saw **[5-4]** must match. Serious injuries may occur in the event of non-compliance.

- ▶ Insert the outer flange **[5-7]** in such a way that the pulling peg engages in the recess of the inner flange.
- ▶ Tighten the screw **[5-5]**.
- ▶ Hold the saw unit securely by its handle, close the lever **[5-3]** and guide the saw unit back upwards.

7.6 Inserting the splinter guard [6]

With 0° cuts, the **splinter guard** (green) **[6-2]** also improves the quality of the cutting edge of the sawn-off workpiece on the upper side.

- ▶ Insert the splinter guard **[6-2]**.
- ▶ Screw the rotary knob **[6-1]** through the hole into the viewing window.
- ▶ **CAUTION! Only use the rotary knob supplied with your plunge-cut saw.** The rotary knob of another saw may be too long and jam the saw blade.

Sawing a splinter guard

You must bed in the splinter guard before using it:

- ▶ Set the machine to maximum cutting depth.
- ▶ Set the machine speed to 6.
- ▶ Place the machine for sawing the splinter guard on a test piece of wood.

7.7 Dust extraction



WARNING

Health hazard posed by dust

- ▶ Always work with an extractor.
- ▶ Comply with national regulations.
- ▶ When sawing carcinogenic materials, always connect a suitable extraction mobile in accordance with national regulations. Do not use the chip collection bag.

Independent extraction

- ▶ Secure the connection piece **[7-2]** of the dust collection bag **[7-3]** at the extractor connector **[7-1]** with a clockwise rotation.
- ▶ To empty, remove the connection piece of the dust collection bag from the extractor connector with an anti-clockwise rotation.

Blockages in the guard may impair safety features. To avoid blockages, it is therefore better to work with a mobile dust extractor at full suction power.

Static charge may occur when sawing (e.g. MDF). If this is the case, work with a mobile dust extractor and an antistatic suction hose.

Festool mobile dust extractor

A Festool mobile dust extractor with a suction hose diameter of 27/32 mm or 36 mm (36 mm recommended due to the reduced risk of clogging) can be connected to the extractor connector **[7-1]**.

The adapter on a 27 diameter suction hose is inserted into the angle adapter **[7-4]**. The adapter on a 36 diameter suction hose is inserted over the angle adapter **[7-4]**.

CAUTION! A static charge may build up if no antistatic suction hose is used. The user may receive an electric shock and the power tool's electronics may be damaged.

8 Working with the electric power tool



When working on the machine, observe all of the safety warnings that are listed at the start as well as the following rules:

Before starting

- Before each use, check whether the drive unit with the saw blade correctly and fully swivels back up into its initial position in the protective housing. Do not use the saw if the upper end position is not secured. Never clamp or secure the swivelling drive unit at a specific cutting depth. This would mean that the saw blade is not protected.
- Check the plunging mechanism prior to use and do not use the machine if it does not work correctly.
- Check that the saw blade is securely in place.
- Before each use of the saw, check that the KickbackStop is functioning properly (see Section 8.11).
- Make sure that the rotary knob [1-3] is tightened before starting work.
- Make sure that extractor hose and mains power cable do not snag the entire saw cut, either on the workpiece, the workpiece support or hazards on the ground.

During work

- Position the saw's plate such that it is always completely level during any work.
- When working, always hold the power tool **with both hands** on the handles [1-11]. This is a prerequisite for precise work and is essential for plunge-cutting. Plunge into the workpiece slowly and evenly.
- Only guide the power tool towards the workpiece when it is switched on.
- Always push the saw forwards [11-2], and **never towards yourself**.
- Adapt the infeed speed to prevent the cutters on the saw blade from overheating and prevent plastic materials from melting during cutting. The harder the material to be sawn, the lower the feed speed needs to be.
- Do not work with the machine if the electronics are defective, because this may lead to excessive speeds. You can tell if the electronics are defective if there is no smooth start-up or if it is not possible to regulate the speed or where smoke is present or if there is a smell of burning coming from the machine.

8.1 Acoustic warning signals

Acoustic warning signals sound and the machine switches off in the following operating states:



peep — —

Machine overloaded

- ▶ Reduce the load on the machine.

8.2 Switch on/off

Pressing the switch-on lock unlocks the plunging mechanism.

- ▶ Slide the switch-on lock [1-13] upwards and press the on/off switch [1-14] (press = ON / release = OFF).

The saw unit can then be moved downwards. This causes the saw blade to emerge from the protective cover.

8.3 Sawing along the scribe mark

The gauge marker [9-2] displays the cutting line for 0° and 45° cuts (without a guide rail).

8.4 Cutting sections

Position the machine with the front part of the saw table on the workpiece, switch on the machine, push it down to the set cutting depth and push it forward in the cutting direction.

8.5 Sawing cut-outs (plunge cuts)



In order to avoid kickbacks, the following instructions must always be followed when plunge cutting:

- Always position the machine with the rear edge of the saw table against a fixed stop.
- When working with the guide rail, position the machine at the FS-RSP kickback stop (accessory) [11-4], which is clamped to the guide rail.

Procedure

- ▶ Place the machine on the workpiece and position it at a stop (KickbackStop).
- ▶ Switch on the machine.
- ▶ Slowly push the machine down to the set cutting depth and push it forward in the cutting direction.

The marks [9-1] indicate the absolute front and rear cutting points of the saw blade (Ø 168 mm) when using the saw at maximum cutting depth with the guide rail.

8.6 Gypsum and cement-bound fibreboards

Due to the high volume of dust, it is recommended to use the cover ABSA-TS55/60 (accessories) which can be mounted at the side at the protective cover and a Festool mobile dust extractor.

8.7 KickbackStop function



WARNING

Risk of injury

The KickbackStop does not guarantee complete protection against a kickback.

- ▶ Always concentrate on your work and refer to the safety instructions and warnings.

A kickback while working may cause the saw to lift unintentionally.

The feeler wedge **[8-1]** detects unintentional lifting (kickback) of the saw from the workpiece or a rail during work and triggers the quick-acting braking of the saw blade (Fig. **[8A]**).

This reduces the risk of a kickback. However, it cannot be entirely ruled out.

KickbackStop function status LED

Colour	Meaning
Green	The KickbackStop function is active.
Orange	The KickbackStop function is deactivated.
Flashing orange	The KickbackStop function is not active. The saw was started up before the feeler wedge was pressed against the workpiece or a guide rail. The saw's plate is not positioned such that it is completely level. Once the saw has been positioned such that it is completely level, the LED will switch to green. If this is not the case, check the KickbackStop function (see Section 8.11)
Flashing red	The KickbackStop function has been triggered.

8.8 Unintentional triggering of the KickbackStop function

Working without a guide rail on an uneven workpiece may cause the KickbackStop function to trigger unintentionally (Fig. **[8B]**).

The feeler wedge **[8-1]** runs along the workpiece. If there is a recess in the workpiece, the position of the feeler wedge will correspond to the position when the workpiece or guide rail is lifted. This triggers the KickbackStop function. It may then be necessary to work without the KickbackStop function (see Section [8.10](#)).

8.9 Procedure after the KickbackStop function has been triggered

Triggered by unintentional lifting (kickback)

- ▶ Determine and eliminate any reasons for lifting.
- ▶ Check the machine for any damage.
- ▶ Check the feeler wedge for any damage.
- ▶ Check the KickbackStop function (see Section [8.11](#)).

After the KickbackStop function has unintentionally been triggered

- ▶ Release the on/off switch and wait until the KickbackStop function status LED is no longer flashing.
- ▶ Check whether there was an unintentional triggering of the KickbackStop function (see Section [8.8](#)) or a kickback.
- ▶ Try first to continue working with an active KickbackStop function. Only deactivate the KickbackStop function if you are working without a rail and your workpiece is so uneven that the KickbackStop function would unintentionally be triggered several times (see Section [8.10](#)).

8.10 Working without the KickbackStop function



WARNING

Risk of injury

If the KickbackStop function is deactivated, the saw blade is not stopped when it unintentionally lifts.

- ▶ Only deactivate the KickbackStop function if you are working without a rail and your workpiece is so uneven that the KickbackStop function would unintentionally be triggered several times.

Deactivate the KickbackStop function

- ▶ Press the KickbackStop function OFF button.
- ▶ Press and hold the on/off switch within ten seconds.

The KickbackStop function remains deactivated until the on/off switch is next released.

- ⓘ The KickbackStop function can only be deactivated before the saw is switched on.

8.11 Checking the KickbackStop function



WARNING

Risk of injury from a protruding saw blade.

- ▶ Carry out function testing on the guide rail.
- ▶ Before the function testing:
 - Remove the saw blade,
 - Set the cutting depth to 0 mm (FS).
- ▶ Set the cutting depth to 0 mm (FS).
- ▶ Place the machine on the guide rail.
- ▶ Switch on the machine.
- ▶ Press the KickbackStop function OFF button four times at intervals of at least 0.5 seconds within five seconds.

The KickbackStop function status LED flashes alternately red and green.

- ▶ Within 15 seconds
 - ▷ Press the saw unit down.
 - ▷ Lift the machine at the rear and lower it again.

A signal sounds, the status LED lights up green. The KickbackStop function operates fault-free.

If no signal sounds and the status LED does not switch to green, the KickbackStop function is not operating fault-free.

- ▶ Check whether the function testing was carried out correctly.
- ▶ Clean the feeler unit behind the saw blade (see "Changing the saw blade").

If the function testing remains unsuccessful, the machine must no longer be used. Contact your Festool service workshop.

9 Service and maintenance



WARNING

Risk of injury, electric shock

- ▶ Always pull the mains plug from the socket before performing any servicing and maintenance work.
- ▶ All maintenance and repair work which requires the housing to be opened should always be carried out by an authorised service workshop.



Customer service and repairs must only be carried out by the manufacturer or service workshops. Find the nearest address at:

www.festool.co.uk/service



Always use original Festool spare parts. Order no. at:
www.festool.co.uk/service

Observe the following instructions:

- ▶ Damaged safety devices and parts, such as a faulty lever for changing tools [1-12], must be properly repaired or replaced in a recognised specialist workshop, unless otherwise indicated in the operating manual.
- ▶ Check the condition and fault-free functioning of the recuperating springs, which push the entire drive mechanism bearing into the upper protected end positions.
- ▶ To ensure constant air circulation, always keep the cooling air openings in the housing clean and free of blockages.
- ▶ Use an extractor on all openings in order to remove wood chips and splinters from the power tool. Never open the protective lid [1-23].
- ▶ When working with plaster- and cement-bonded fibreboards, clean the tool particularly thoroughly. Clean the vents of the power tool and on/off switch using dry, oil-free compressed air. Otherwise, gypsum dust deposits may build up inside the power tool's housing and on the on/off switch and harden when exposed to humidity. This may impair the switching mechanism.

9.1 Reconditioned saw blades

You can use the adjusting screw [10-1] to precisely set the cutting depth for reconditioned saw blades.

- ▶ Set the cutting depth stop [10-2] to 0 mm (with guide rail).
- ▶ Unlock the saw unit and push it downwards as far as the stop.
- ▶ Screw the adjusting screw [10-1] in until the saw blade comes into contact with the workpiece.

9.2 Saw table wobbles

i The saw table must be on an even surface when adjusting the cutting angle.

- ▶ If the saw table wobbles, the setting must be implemented again.

9.3 Aligning the angle scale

See figure [12].

10 Accessories

Always use accessories and consumable materials approved by Festool. See Festool www.festool.co.uk.

The power tool may become unsafe and lead to serious accidents if other accessories and consumables are used.

In addition to the accessories described, Festool also provides a comprehensive range of system accessories that allow you to use your machine more effectively and in diverse applications, e.g.:

- Parallel stop PA-TS 60
- Side-mounted cover, false joint ABSA-TS 55/60
- Kickback stop FS-RSP
- Parallel stop FS-PA and guide extension FS-PA-VL
- Angle stop FS-WA and FS-WA/90°
- Mobile saw table and work bench STM 1800
- Multifunction table MFT/3

10.1 Saw blades, other accessories

In order to saw different materials quickly and cleanly, Festool offers saw blades for all applications and these are specially designed for your Festool saw.

10.2 Guide system

The guide rail enables you to make clean, accurate cuts while simultaneously protecting the surface of the workpiece from damage.

In conjunction with the extensive range of accessories, exact angled cuts, mitre cuts and fitting work can be completed with the guide system. The option of attaching the guide rail securely using clamps [11-5] ensures safer working conditions.

- ▶ Adjust the guide play between the saw table and the guide rail using the two adjustable jaws [11-1].

Bed in the splinter guard [11-3] before using the guide rail for the first time:

- ▶ Set the machine speed to 6.
- ▶ Place the machine at the rear end of the guide rail together with the complete guide plate.
- ▶ Switch on the machine.
- ▶ Push down the machine slowly to the max. preset cutting depth and cut along the full length of the splinter guard without stopping.

The edge of the splinter guard now corresponds exactly to the cutting edge.

- ① Position the guide rail for sawing the splinter guard on a test piece of wood.

10.3 Cross cutting guide rail

The cross cutting guide rail is designed for sawing wood and panel materials.

It enables precise and clean cuts, in particular angled cuts can be performed simply and with repeat accuracy. The saw automatically moves back to the initial position after the sawing process.

Observe the instructions in the operating manual for the FSK cross cutting guide rail

11 Environment



Do not dispose of the device in the household waste! Recycle devices, accessories and packaging. Observe applicable national regulations.

EU only: In accordance with the European Directive on waste electrical and electronic equipment and implementation in national law, used power tools must be collected separately and handed in for environmentally friendly recycling.

Information about collection points for correct disposal is available at www.festool.co.uk/recycling.

Information on REACH: www.festool.co.uk/reach

12 General information

Imported into the UK by

Festool UK Ltd
1 Anglo Saxon Way
Bury St Edmunds
IP30 9XH
Great Britain

12.1 Information on data privacy

The power tool contains a chip which automatically stores machine and operating data. The data saved cannot be traced back directly to an individual.

The data can be read in a contactless manner using special devices and shall only be used by Festool for fault diagnosis, repair and warranty processing and for quality improvement or enhancement of the power tool. The data shall not be used in any other way without the express consent of the customer.