

de	Originalbetriebsanleitung - Exzentrerschleifer	7
en	Original Instructions - Eccentric sander	12
fr	Notice d'utilisation d'origine - Ponceuse excentrique	17
es	Manual de instrucciones original - Lijadora excéntrica	23
it	Istruzioni per l'uso originali - Levigatrice orbitale	28
nl	Originele gebruiksaanwijzing - Excenterschuurmachine	33
sv	Originalbruksanvisning - Excenterslipmaskin	38
fi	Alkuperäiset käyttöohjeet - Epäkeskoihomakone	43
da	Original brugsanvisning - Excentersliber	48
nb	Originalbruksanvisning - Eksentersliper	53
pt	Manual de instruções original - Lixadora excêntrica	58
ru	Оригинал Руководства по эксплуатации - Эксцентриковая шлифмашина	63
cs	Originál návodu k obsluze - Excentrická bruska	69
pl	Oryginalna instrukcja eksploatacji - Szlifierka mimośrodowa	74

ETS 125 REQ

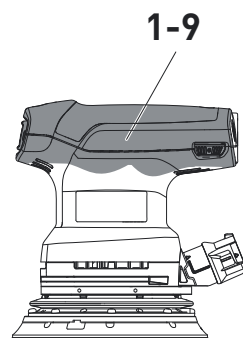

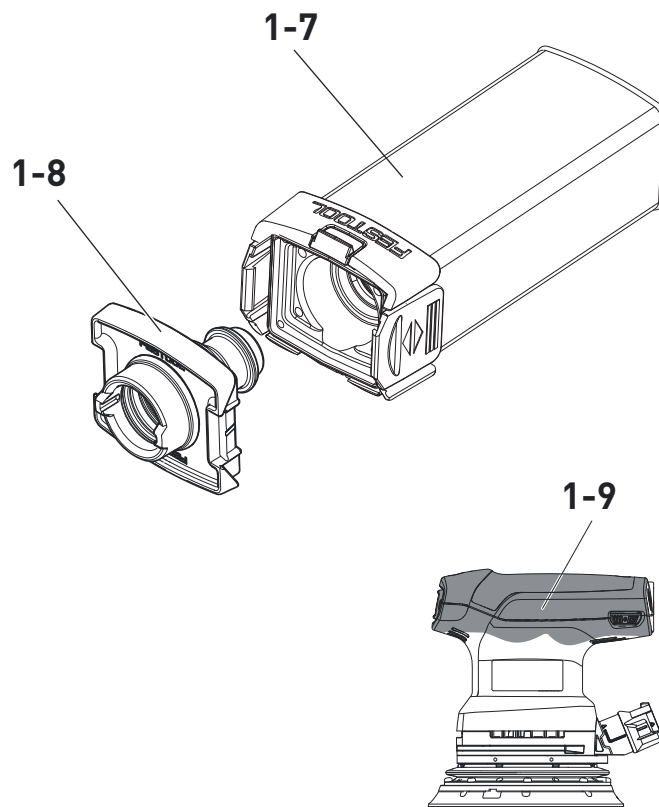

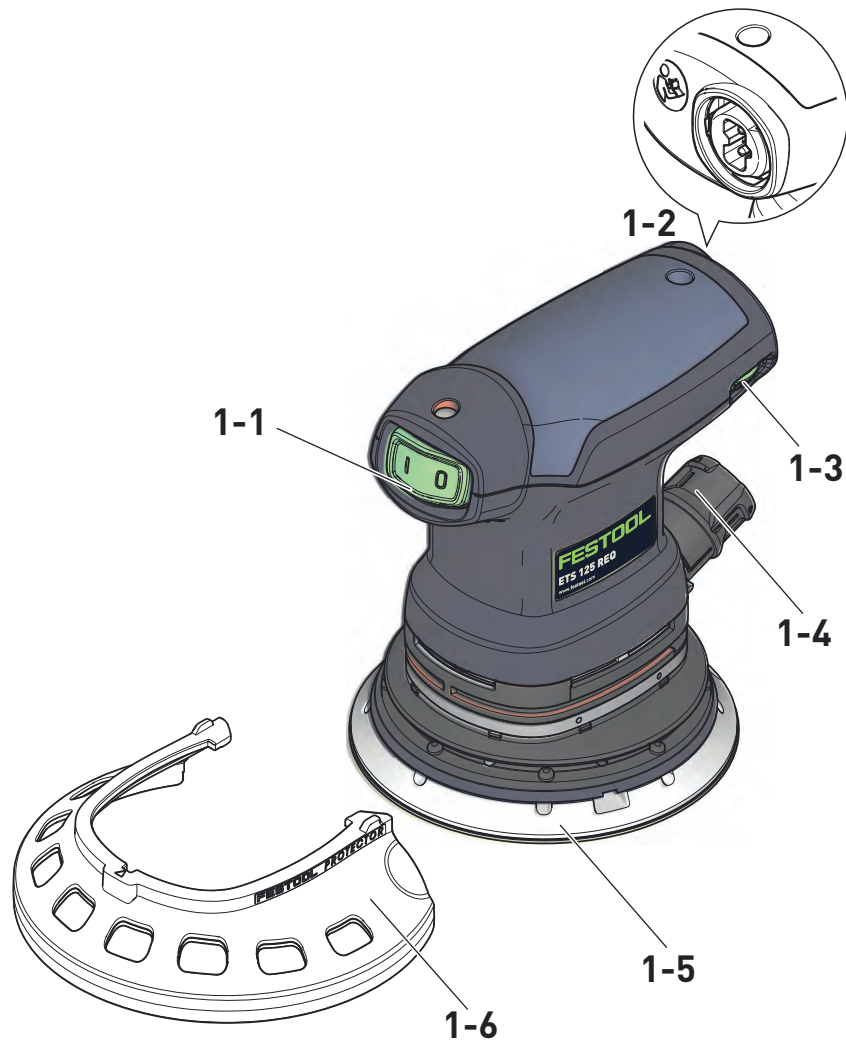
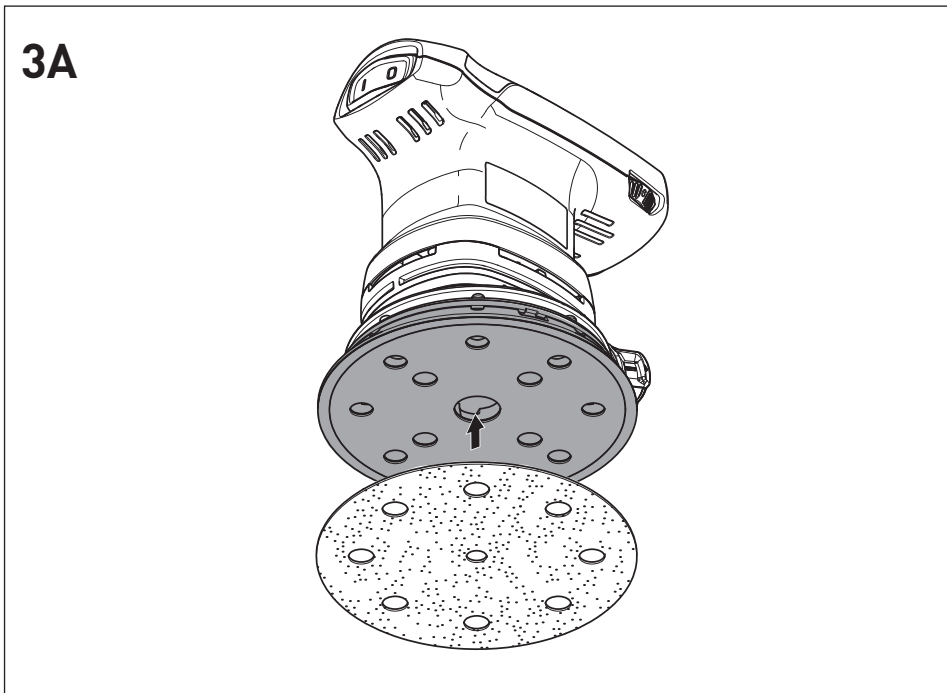
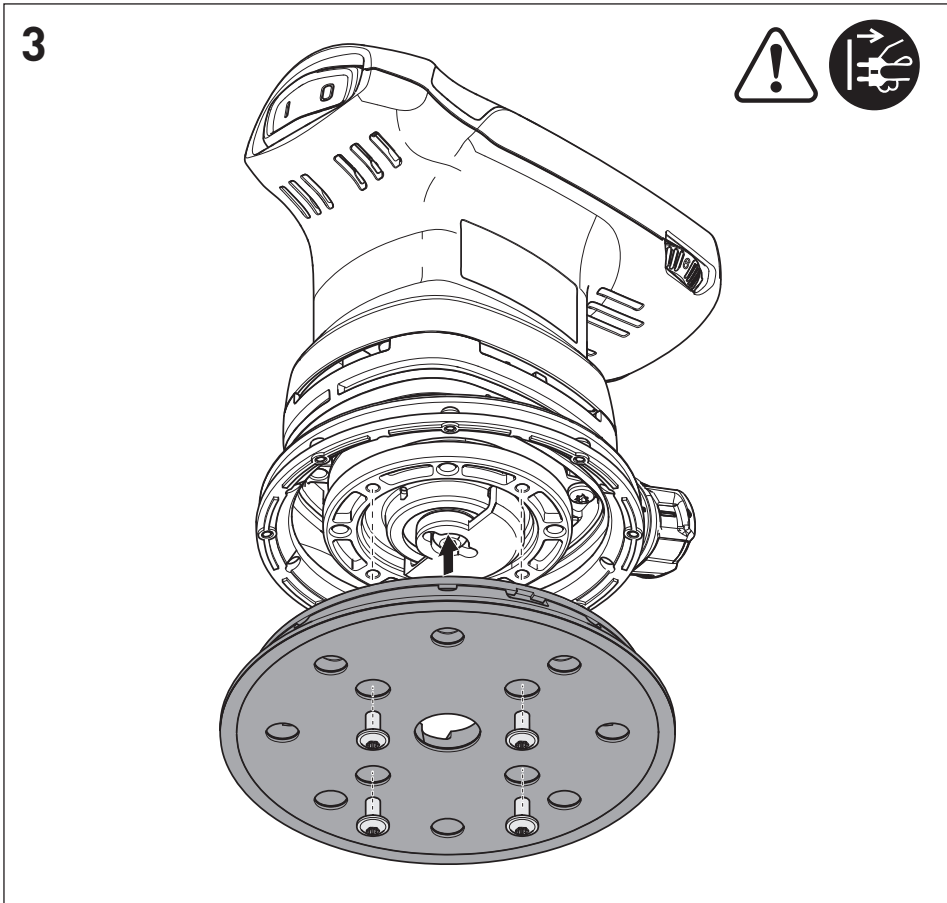
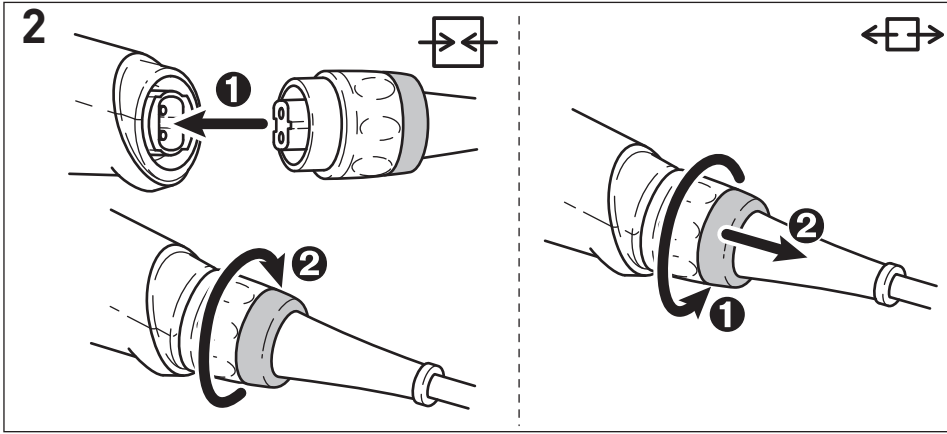

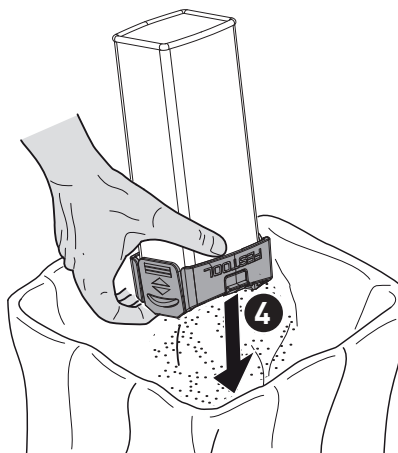
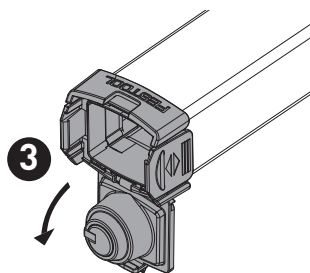
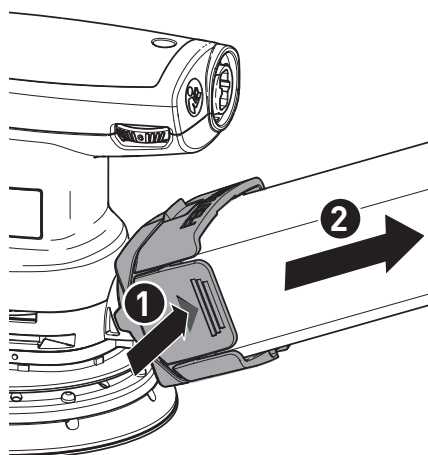
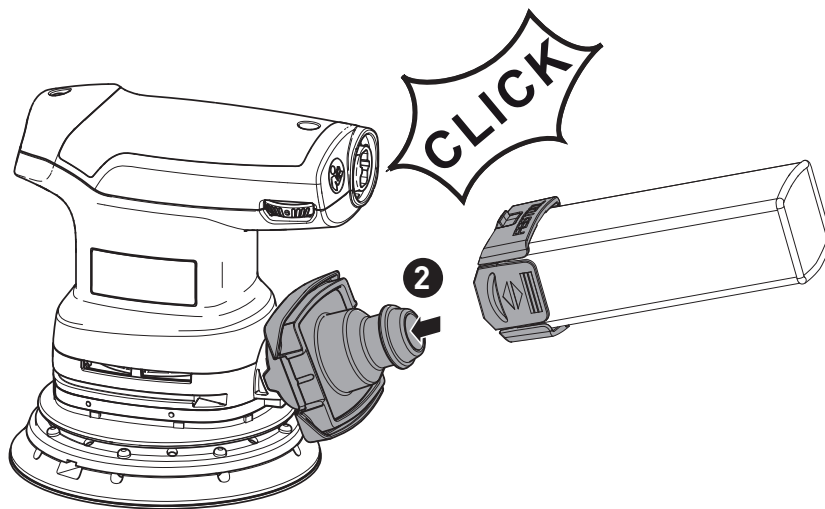
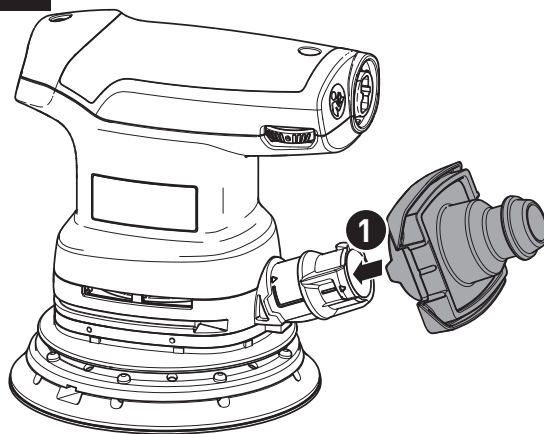
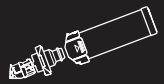

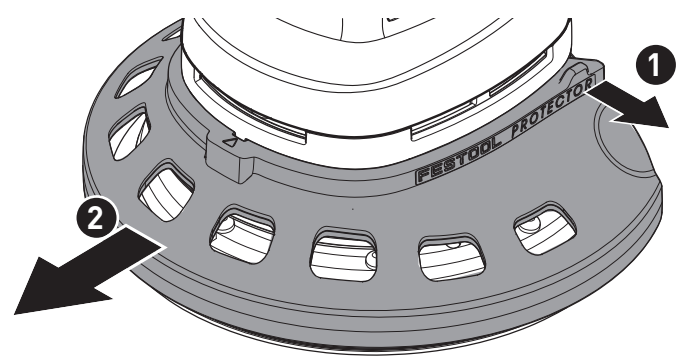
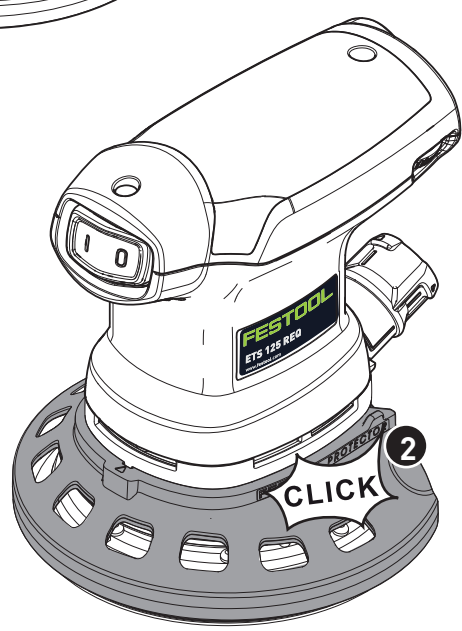
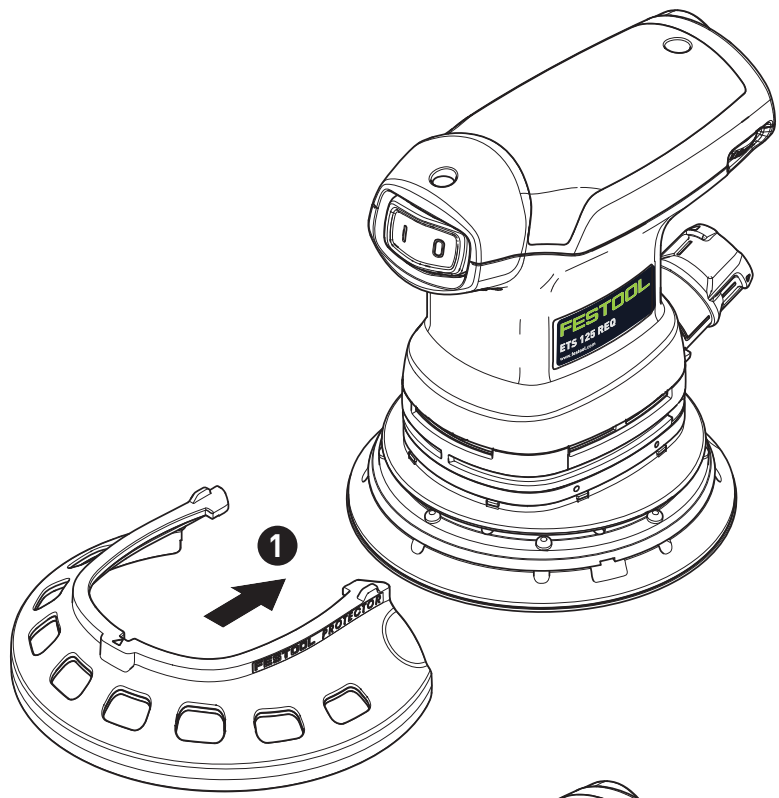

Exzenterschleifer
Eccentric sander
Ponceuse excentrique

Seriennummer *
Serial number *
N° de série *
(T-Nr.)

ETS 125 REQ

201416

(D) EG-Konformitätserklärung. Wir erklären in alleiniger Verantwortung, dass dieses Produkt allen einschlägigen Bestimmungen der folgenden Richtlinien einschließlich ihrer Änderungen entspricht und mit den folgenden Normen übereinstimmt:

(GB) EC-Declaration of Conformity. We declare under our sole responsibility that this product is in conformity with all relevant provisions of the following directives including their amendments and complies with the following standards:

(F) CE-Déclaration de conformité communautaire. Nous déclarons sous notre propre responsabilité que ce produit est conforme aux normes ou documents de normalisation suivants:

(E) CE-Declaración de conformidad. Declaramos bajo nuestra exclusiva responsabilidad que este producto corresponde a las siguientes normas o documentos normalizados:

(I) CE-Dichiarazione di conformità. Dichiariamo sotto la nostra esclusiva responsabilità che il presente prodotto è conforme alle norme e ai documenti normativi seguenti:

(NL) EG-conformiteitsverklaring. Wij verklaren op eigen verantwoordelijkheid dat dit produkt voldoet aan de volgende normen of normatieve documenten:

(S) EG-konformitetsförklaring. Vi förklarar i eget ansvar, att denna produkt stämmer överens med följande normer och normativa dokument:

(FIN) EY-standardinmukaisuusvakuutus. Vakuutamme yksinvastuullisina, etta tuote on seuraavien standardien ja normatiivisten ohjeiden mukainen:

(DK) EF-konformitetserklæring Vi erklærer at have alene ansvaret for, at dette produkt er i overensstemmelse med de følgende normer eller normative dokumenter:

(N) CE-Konformitetserklæring Vi erklærer på eget ansvar at dette produktet er i overensstemmelse med følgende normer eller normative dokumenter:

(P) CE-Declaração de conformidade: Declaramos, sob a nossa exclusiva responsabilidade, que este produto corresponde às normas ou aos documentos normativos citados a seguir:

(RUS) Декларация соответствия ЕС: Мы заявляем с исключительной ответственностью, что данный продукт соответствует следующим нормам или нормативным документам:

(CZ) ES prohlášení o shodě: Prohlašujeme s veškerou odpovědností, že tento výrobek je ve shodě s následujícími normami nebo normativními dokumenty:

(PL) Deklaracja o zgodności z normami UE: Niniejszym oświadczamy na własną odpowiedzialność, że produkt ten spełnia następujące normy lub dokumenty normatywne:

2006/42/EG, 2014/30/EU, 2011/65/EU

EN 62841-1: 2015

EN 62841-2-4: 2014

EN 55014-1: 2006 + A1: 2009 + A2: 2011

EN 55014-2: 2015

EN 61000-3-2: 2015

EN 61000-3-3: 2014

EN 50581: 2012



Festool GmbH

Wertstr. 20, D-73240 Wendlingen
GERMANY

Wendlingen, 2017-08-09

Wolfgang Zondler

Head of Research, Development and Technical Documentation

Ralf Brandt

Head of Standardization & Approbation

* im definierten Seriennummer-Bereich (S-Nr.) von 40000000 - 49999999

in the specified serial number range (S-Nr.) from 40000000 - 49999999

dans la plage de numéro de série (S-Nr.) de 40000000 - 49999999

Contents

1	Symbols.....	12
2	Safety warnings.....	12
3	Intended use.....	13
4	Technical data.....	13
5	Parts of the machine.....	13
6	Operation.....	14
7	Settings.....	14
8	Working with the electric power tool.....	15
9	Service and maintenance.....	16
10	Accessories.....	16
11	Environment.....	16
12	General information.....	16

1 Symbols



Warning of general danger



Warning of electric shock



Read the operating manual and safety instructions.



Wear ear protection.



Wear a dust mask.



Wear protective goggles.



Connecting the mains power cable



Disconnecting the mains power cable



Pull out the mains plug



Do not dispose of it with domestic waste.



Safety class II



CE marking: Confirms the conformity of the power tool with the European Community directives.



Tool contains a chip which stores data. See section [12.1](#)



Tip or advice



Handling instruction

2 Safety warnings

2.1 General power tool safety warnings



WARNING! Read all safety warnings, instructions, illustrations and specifications provided with this power tool. Failure to follow all instructions listed below may result in electric shock, fire and/or serious injury.

Save all warnings and instructions for future reference.

The term "power tool" in the warnings refers to your mains-operated (corded) power tool or battery-operated (cordless) power tool.

- **Only for AS/NZS:** The tool shall always be supplied via residual current device with a rated residual current of 30 mA or less.

2.2 Machine-specific safety notices

- **Harmful/poisonous dust may be produced when working (e.g. paint products containing lead and some types of wood).** Contact with or inhalation of this dust may pose a risk for the operating personnel or persons in the vicinity. Comply with the safety regulations that apply in your country.



- **Wear suitable personal protective equipment:** Ear protection and safety goggles.



- Wear a P2 respiratory mask to protect your health. In enclosed spaces, ensure that there is sufficient ventilation and connect a mobile dust extractor.
- **Clean using materials soaked in oils, e.g. abrasive pad or polishing felt with water, and spread them out to dry.** Materials soaked in oil may ignite spontaneously.
- **Caution: Fire hazard! Prevent the material being sanded and the sander from overheating. Always empty the dust container before taking breaks from work.** Grinding dust in the filter bag and/or in the filter of the mobile dust extractor may ignite spontaneously under unfavourable conditions, such as flying sparks, when sanding. There is a particular risk if the sanding dust is mixed with clear coats or polyurethane residues or other chemical substances and the material being sanded becomes hot after it has been worked on for a long time.
- Metals and materials that contain asbestos must not be processed. Sparks may be cre-

ated in the dust bag when processing metals. This increases the risk of fire.

- **If the power tool is dropped or falls, check for damage to the machine and sanding pad. Remove the sanding pad for closer inspection. Have the damaged parts repaired before use.** Broken sanding pads and damaged machines can cause injuries and machine instability.
- **Always use original Festool sanding pads.** Sanding pads from other manufacturers are not suitable for the sander speed and may break.
- **An electrostatic charge may build up when using the long-life dust bag. If possible, always use the power tool with an anti-static suction hose (AS).** A slight electric shock may cause you to panic briefly and become distracted, which may result in an accident.

2.3 Emission levels

The levels determined in accordance with EN 62841 are typically:

Sound pressure level	$L_{PA} = 73 \text{ dB(A)}$
Sound power level	$L_{WA} = 84 \text{ dB(A)}$
Uncertainty	$K = 3 \text{ dB}$



CAUTION

Noise generated when working

Risk of damage to hearing

- Use ear protection.

Vibration emission level a_h (vector sum for three directions) and uncertainty K measured in accordance with EN 62841:

Vibration emission value (3-ax-
is) $a_h = 4.0 \text{ m/s}^2$

$K = 2.0 \text{ m/s}^2$

The specified emission levels (vibration, noise)

- are used to compare machines.
- They are also used for making preliminary estimates regarding vibration and noise load during operation.
- They represent the primary applications of the power tool.



CAUTION

The emission values may deviate from the specified values. This is dependent on how the tool is used and the type of workpiece being machined.

- The actual load during the entire operating cycle must be evaluated.
- Depending on the actual load, suitable protective measures must be defined in order to protect the operator.

3 Intended use

The sanders are designed for sanding wood, plastic, composites, paint/varnish, filler and similar materials as directed. Metals and materials that contain asbestos must not be processed.

To guarantee electrical safety, the machine must not be damp or operated in a damp environment. The machine must only be used for dry sanding.



The user is liable for improper or non-intended use.

4 Technical data

Eccentric sanders	ETS 125REQ
Performance	250 W
Speed (idle)	6000 - 12000 rpm
Max. speed ^[2]	16000 rpm
Sanding stroke	2,0 mm
Sanding pad	D 125 mm
Weight (without mains cable, with sanding pad)	1,2 kg

5 Parts of the machine

- [1-1]** On/off switch
- [1-2]** Plug-it connection
- [1-3]** Speed control
- [1-4]** Extractor connector
- [1-5]** Sanding pad
- [1-6]** Protector
- [1-7]** Long-life dust bag

[2] Max. speed in the event of faulty electronics.

[1-8] Dust bag adapter

[1-9] Handle (insulated gripping surfaces)

The specified illustrations appear at the beginning of the Operating Instructions.

6 Operation



WARNING

Unauthorised voltage or frequency.

Risk of accidents

- ▶ The mains voltage and the frequency of the power source must correspond to the specifications on the machine's name plate.
- ▶ In North America, only Festool machines with the voltage specifications 120 V/60 Hz must be used.



CAUTION

Heating of the Plug it connection if bayonet fitting is not completely locked

Risk of burns

- ▶ Before switching on the power tool, make sure that the bayonet fitting at the mains cable is closed fully and locked.

Connecting and detaching the mains power cable - see figure .

The switch **[1-1]** serves as an on/off switch (I = ON, 0 = OFF).

- If there is a power failure or the mains plug is removed, move the on/off switch immediately to the Off position. This prevents uncontrolled restarting.

7 Settings



WARNING

Risk of injury, electric shock

- ▶ Always disconnect the mains plug from the socket before performing any work on the machine.

7.1 Electronics

Smooth start-up

The electronically controlled smooth start-up ensures that the machine starts up jolt-free.

Constant speed

The preselected motor speed is kept constant through electronic control. This means that, if the machine is used as intended (reasonable

contact pressure), a constant sanding speed is achieved.

Setting the speed

The speed can be adjusted between 6000 and 12,000 rpm using the adjusting wheel **[1-3]**.

This enables you to optimise the sanding speed to suit the material you are working on (see Section 8).

7.2 Replacing the sanding pad [3]



An optimal work result can only be achieved using original accessories and consumables. The use of non-original accessories or consumables invalidates the right to claim under warranty.



Warning! Do not perform any structural changes in the open interior space of the machine when the sanding pad is dismantled.

1 Undo the four screws.

2 Remove the sanding pad by pulling it downwards.

3 Attach the new sanding pad.

4 Use four screws to tighten it by hand (2.5 Nm).

Hardness of the sanding pad

Adapted to the surface being processed, the machine can be equipped with sanding pads of different hardnesses.

Soft: Universal for coarse and fine sanding, for flat and convex surfaces.

Extra-soft: Fine sanding of moulded parts, arches, radii. Do not use on edges.

7.3 Attaching sanding accessories using StickFix [3a]

The suitable StickFix sandpaper and StickFix sanding cloth can be attached quickly and simply to the StickFix sanding pad.

- ▶ Affix the self-adhesive sanding accessory to the sanding pad.**[1-5]**



In the case of a weakening adhesive effect of the StickFix surface, the sanding pad accessories, in particular those which are not yet touching the workpiece, **may come loose from the sanding pad and cause injuries.** Replace the sanding pad!

7.4 Dust extraction



WARNING

Dust hazard

- ▶ Dust can be hazardous to health. Always work with a dust extractor.
- ▶ Always read applicable national regulations before extracting hazardous dust.

Integral dust extractor with long-life dust bag

As standard, the sanders are equipped with an integral dust extractor. The sanding dust is extracted through extraction openings in the sanding pad and is collected in the dust bag.

Installing the dust bag [4]

- ❶ Slide the dust bag adapter onto the extractor connection piece.
- ❷ Slide the dust bag onto the adapter until it clicks into place.



If the suction power is decreasing, empty the dust bag.

- ❶ Press the dust bag onto the actuating elements.
- ❷ Remove the dust bag by moving it towards the rear.
- ❸ Open the flap on the dust bag.
- ❹ Empty the dust bag and dispose of the waste.

Dust extraction with Festool's mobile dust extractor

To prevent having to frequently empty the dust bag when carrying out sanding work for a long period of time, you can connect Festool's mobile dust extractor (with an extraction hose diameter of 27 mm) to the extractor connection piece [1-4].

Recommendation: Use an antistatic suction hose. This helps reduce the electric charge.

7.5 Edge protector [5]

The edge protector [1-6] reduces contact of the sanding pad circumference with a surface (e.g. when sanding along a wall or a window), thus preventing back-kick of the machine, or machine damage.

8 Working with the electric power tool



WARNING

Risk of injury

- ▶ Always secure the workpiece in such a manner that it cannot move while being machined.

Observe the following information:

- Do not overload the machine by pressing with excessive force! The best sanding results are achieved with moderate application pressure. The sanding performance and quality are mainly dependent on the selection of the correct abrasive.
- Hold the machine with one hand by the handle [1-9] to ensure safe guidance.

For sanding, we recommend the following settings for the adjusting wheel [1-3]:

Sanding work	Adjusting wheel setting
- Sanding with max. abrasion	5-6
- Sanding off old paint	
- Sanding of wood and veneered surface prior to paintwork	
- Intermediate sanding of paintwork on surfaces	
- Sanding thinly applied undercoat	4-5
- Sanding wood with sanding cloth	
- Edge breaking on wooden parts	
- Smoothing primed wooden surfaces	
- Sanding solid wood and veneered edges	3-4
- Sanding rebate of windows and doors	
- Intermediate sanding of paintwork at edges	
- Light sanding of natural wood windows using sanding cloth	
- Smoothing wooden surfaces using sanding cloth before staining	
- Rubbing stained surfaces with a sanding cloth	
- Rubbing or removing excess limestone residue using sanding cloth	
- Intermediate sanding of paintwork on stained surfaces	2-3
- Cleaning natural wood window rebate using sanding cloth	
- Sanding stained edges	1-2
- Sanding thermoplastics	

9 Service and maintenance



WARNING

Risk of injury, electric shock

- ▶ Always pull the mains plug from the socket before performing any servicing and maintenance work.
- ▶ All maintenance and repair work which requires the motor housing to be opened should always be carried out by an authorised service workshop.



Customer service and repairs must only be carried out by the manufacturer or service workshops. Find the nearest address at:
www.festool.com/service

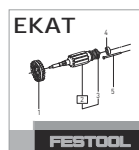

Always use original Festool spare parts. Order no. at:
www.festool.com/service

The tool is equipped with special self-disconnecting carbon brushes. If they wear out, the power supply is disconnected automatically and the tool stops.

To ensure constant air circulation, always keep the cooling air openings in the motor housing clean and free of blockages.

In the event of a slowdown in performance or increased vibrations, blow and clean cooling air openings.

10 Accessories

Only use original Festool sanding and polishing pads. Low-quality sanding and polishing pads may cause serious machine imbalance that decreases the quality of the working results and increases machine wear.

The PO numbers of the accessories and tools can be found in the Festool catalogue or online at "www.festool.co.uk".

11 Environment



Do not dispose of the device in the household waste! Recycle devices, accessories and packaging. Observe applicable national regulations.

EU only: In accordance with the European Directive on waste electrical and electronic equipment and implementation in national law, used power tools must be collected separately and handed in for environmentally friendly recycling.

Information on REACH: www.festool.com/reach

12 General information

12.1 Information on data protection

The power tool contains a chip which automatically stores machine and operating data. The data saved cannot be traced back directly to an individual.

The data can be read using special (contactless) devices and shall only be used by Festool for fault diagnosis, repair and warranty processing and for quality improvement or enhancement of the power tool. The data shall not be used in any other way without the express consent of the customer.