

# charnwood

*Woodworking machinery at its best!*

**DRUM SANDER  
OWNERS MANUAL  
MODEL: DS10/20**



**CE  
UK  
CA**

**Charnwood Machinery, Cedar Court, Walker Road, Hilltop Industrial Estate,  
Bardon Hill, Leicestershire, LE67 1TU**

**Tel. 01530 516 926  
email: [sales@charnwood.net](mailto:sales@charnwood.net)**

**Fax. 01530 516 929  
website: [www.charnwood.net](http://www.charnwood.net)**

# GENERAL SAFETY RULES



**WARNING:** Do not attempt to operate the machine until you have read thoroughly and understood completely all instructions, rules, etc. contained in this manual. Failure to comply may result in accidents involving fire, electric shock, or serious personal injury. Keep this owner's manual and review frequently for continuous safe operation.

1. Know your machine. For your own safety, read the owner's manual carefully. Learn its application and limitations, as well as specific potential hazards pertinent to this machine.
2. Make sure all tools are properly earthed.
3. Keep guards in place and in working order. If a guard must be removed for maintenance or cleaning, make sure it is properly replaced before using the machine again.
4. Remove adjusting keys and spanners. Form a habit of checking to see that all keys and adjusting spanners are removed from the machine before switched it on.
5. Keep your work area clean. Cluttered areas and workbenches increase the chance of an accident.'
6. Do not use in dangerous environments. Do not use power tools in damp or wet locations, or expose them to rain. Keep work areas well illuminated.
7. Keep children away. All visitors should be kept a safe distance from the work area.
8. Make workshop childproof. Use padlocks, master switches and remove starter keys.
9. Do not force the machine. It will do the job better and be safer at the rate for which it is designed.
10. Use the right tools. Do not force the machine or attachments to do a job for which they are not designed. Contact the manufacturer or distributor if there is any question about the machine's suitability for a particular task.
11. Wear proper apparel. Avoid loose clothing, gloves, ties, bracelets, and jewellery which could get caught in moving parts. Non-slip footwear is recommended. Wear protective hair covering to contain long hair.
12. Always use safety glasses. Normal spectacles only have impact resistant lenses. They are not safety glasses.
13. Do not over-reach. Keep proper footing and balance at all times.
14. Maintain the machine in good condition. Keep the machine clean for best and safest performance. Follow instructions for lubrication and changing accessories.
15. Disconnect the machine from power source before servicing and when changing the blade.
16. Never leave the machine running unattended. Turn the power off. Do not leave the machine until it comes to a complete stop.
17. Do not use any power tools while under the effects of drugs, alcohol or medication.
18. Always wear a face or dust mask if operation creates a lot of dust and/or chips. Always operate the tool in a well ventilated area and provide for proper dust removal. Use a suitable dust extractor.



Risk of Injury!  
Never reach into  
a rotating drum



Wear Eye  
Protection



Wear Ear  
Protection

# Rating Description

**Hobby:** Suitable for Weekend DIY'ers and woodworking enthusiasts.

Generally lighter weight machines with lower power ratings and smaller tooling capacities.

Typically only ever used by one person for short periods of time or longer periods of time infrequently. Machinery should be well maintained in a clean, dry environment such as a home workshop, garage or timber shed. **Expected maximum use of 100 hours annually.**

**Please Note:** Using a product in excess of its rating will void the manufacturer's free warranty.

## Charnwood DS10/20 Specification

Maximum Width (1 Pass)	255mm (10")
Maximum Width (2 Passes)	505mm (20")
Maximum Workpiece Thickness	75mm (3")
Minimum Workpiece Thickness	5mm (1/5")
Minimum Length	65mm (2.6")
Sandpaper Wrap (Width x Length)	82mm x 1550mm
Drum Motor (Induction)	1100w (1.5hp), 240v, 50hz
Drum Speed	1440rpm
Drum Size (Diameter / Length)	132mm / 260mm
Conveyor Motor (DC)	50w (1/15hp)
Conveyor Speed (Variable)	0-3.5m/min
Dust Port Diameter	100mm
Dust Collection Minimum Requirement	1000m <sup>3</sup> /hour (50 Litres per second)
Assembled Dimensions (WxDxH)	900 x 590 x 1140mm
Shipping Dimensions (WxDxH)	800 x 640 x 640mm
Weight	72kg
Rating	Hobby
Product Guarantee	1 Year

## Unpacking

	<p><b>Open The Crate</b></p> <p>This product is packed into 1 wooden crate.</p> <p>To open the wooden crate:</p> <p>Cut the vertical straps</p> <p>Use a pry bar to release the nails around the base</p> <p>Lift off the complete lid.</p>
---	---

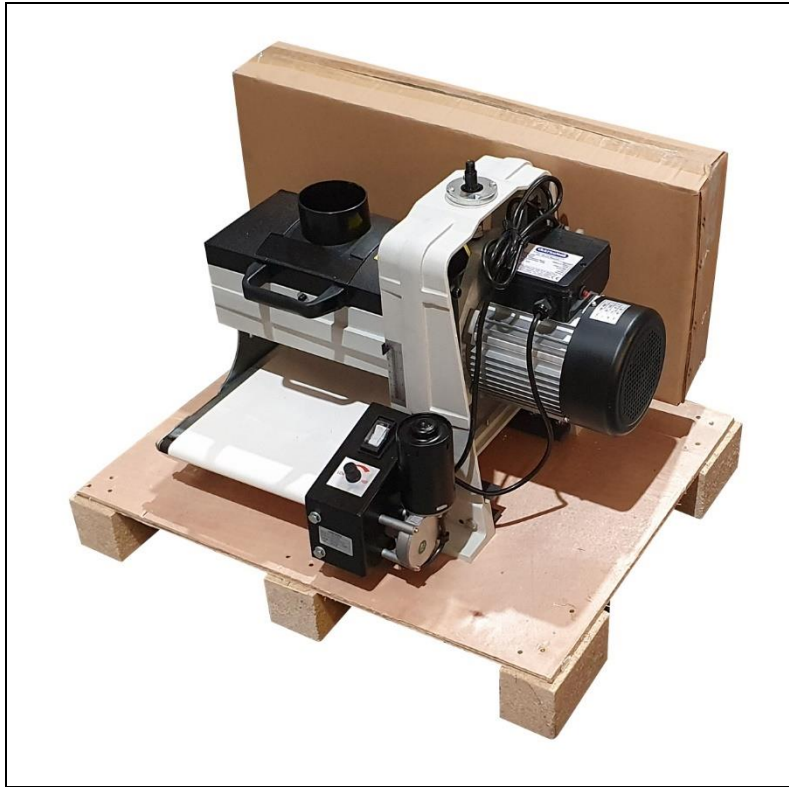

**Remove Loose Items**

Remove the plastic cover and the carton of loose parts.



**Unbolt From The Base**

The machine is fixed to the pallet base with 2 bolts.

Use a pair of 13mm spanner to undo the 2 securing nuts.



This part of the assembly requires 2 people:

Lift the machine off the pallet base.

Do not dispose of any of the packaging until the machine has been completely assembled and tested.  
In the unlikely event that the product needs to be returned, the original packaging will be required.

# Identify The Loose Parts

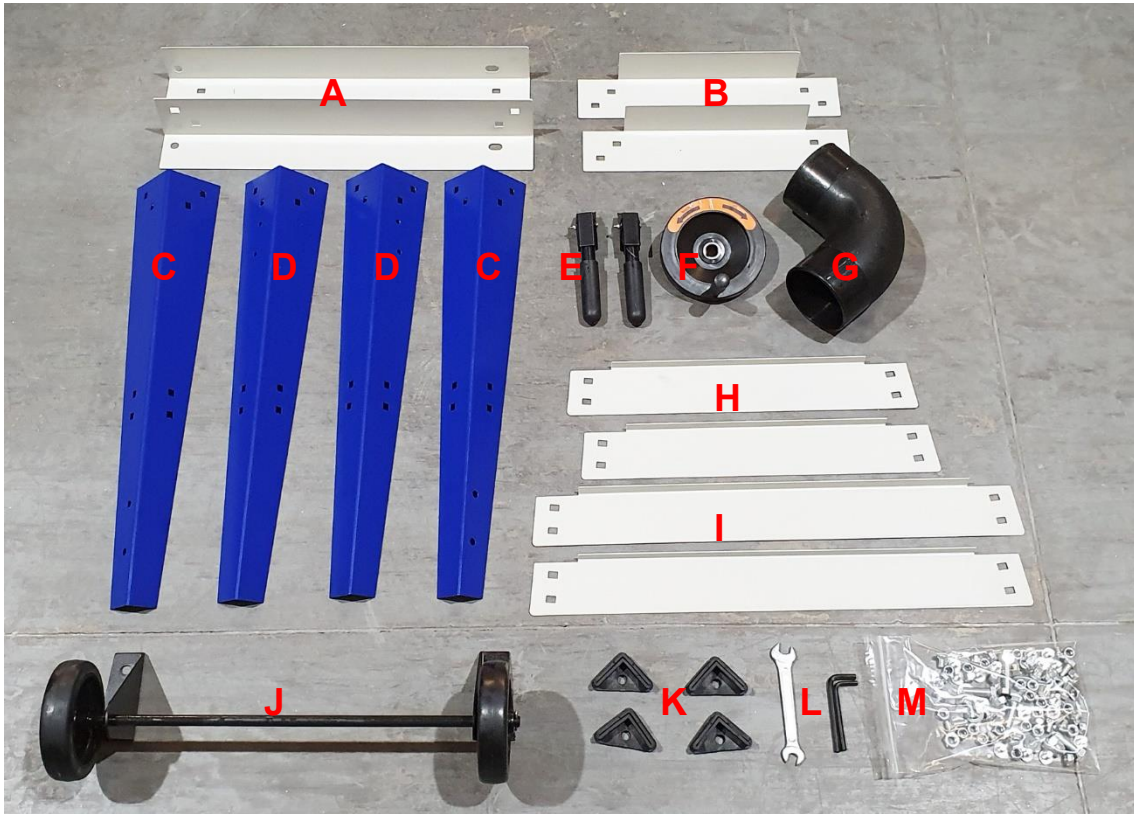

- A)** Long Top Frame
- B)** Short Top Frame
- C)** Leg – Wheel Kit End
- D)** Leg – Lifting Handle End
- E)** Lifting Handles
- F)** Hand Wheel
- G)** Dust Extractor Elbow
- H)** Short Cross Brace
- I)** Long Cross Brace
- J)** Wheel Kit
- K)** Rubber Feet
- L)** Service Tools
- M)** Fixing Bolts

# Assembly

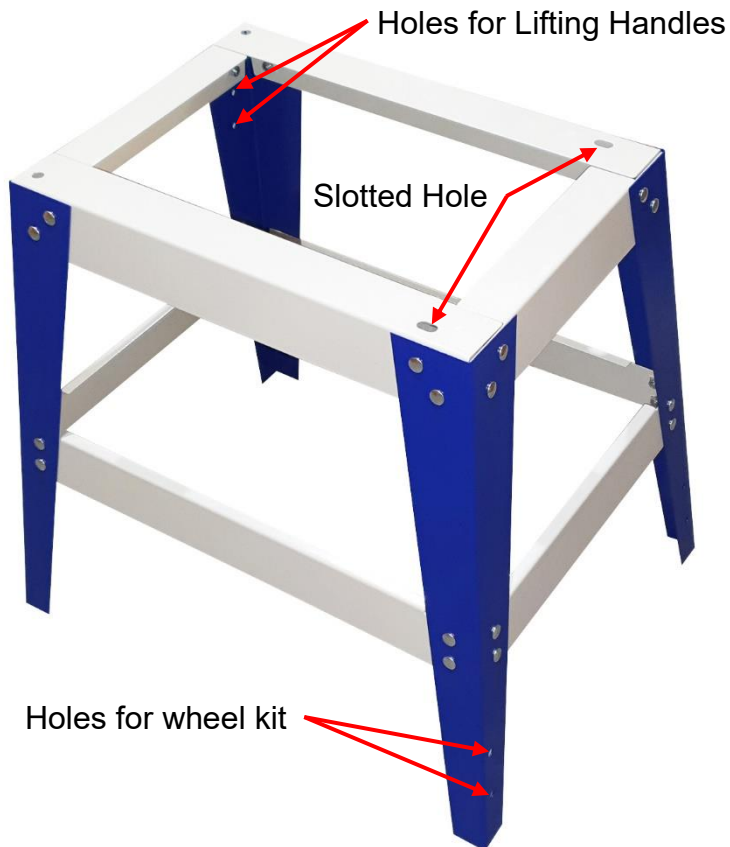

## Assemble The Stand

Identify the 2 legs, **C**, which have 2 additional holes near the bottom for the wheel kit.

Assemble these with the Short Cross Brace **H** and the Short Top Frame **B**, to form one end of the stand. Note: The legs go on the outside.

Use 2 square head bolts and nyloc nuts for each joint. Leave all nuts finger tight for now.

Repeat for the other 2 legs which have additional holes for the lifting handles.

Now assemble the 2 end frames with the Long Cross Brace **I** and Long Top Frame **A**.

One end of the Long Top Frame **A**, has a slotted hole. This end goes towards the Wheel Kit end of the stand.

Place the stand on a flat surface and tighten all the nuts with a 13mm spanner.





## Fit The Feet

Push the 4 rubber feet onto the ends of the legs.

## Attach The Wheel Kit

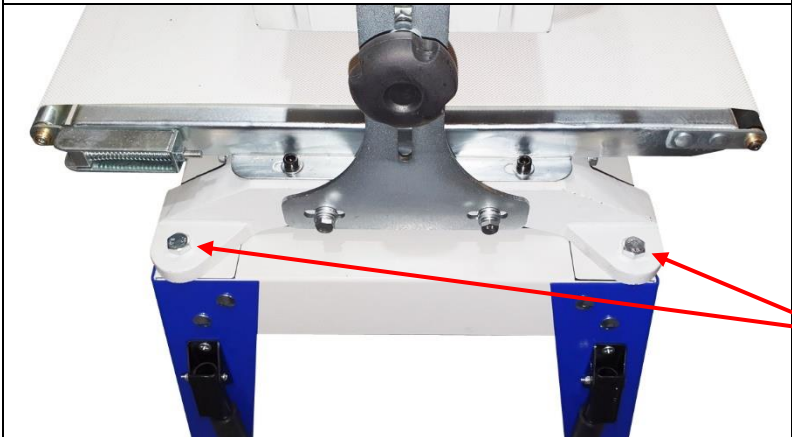
Use 4 bolts and nyloc nuts to attach the Wheel Kit. Tighten with a pair of 13mm spanners.

	<p><b>Attach The Handles</b></p> <p>The lifting handles attach using countersunk screws and nuts.</p> <p>Tighten using a cross head screw driver and 10mm spanner.</p> <p>The handles fold down when not in use.</p>
	<p><b>Attach The Sander To The Stand</b></p> <p>Lift the body of the sander onto the floor stand with the motor above the wheels.</p> <p>Secure it with 4 bolts, Washers and Nuts.</p> <p>Tighten using a pair of 16mm spanners.</p>
	<p><b>Attach The Handwheel</b></p> <p>Fit the handwheel onto the shaft and align the slot with the key way.</p> <p>Fit the washer and domed nut. Tighten using an 18mm spanner.</p> <p><b>Attach The Elbow</b></p> <p>Fit the dust collector elbow. It can be directed as required, ready to attach a 100mm diameter extractor hose.</p>

# Using The Drum Sander



## Operating The Sander

### Drum Sander Vs Thicknesser

Drum sanding gradually removes material in increments of 0.8mm or less depending on sanding grit, stock hardness, stock width, etc. Thicknessing, on the other hand, is for quick, bulk material removal at rates up to 3mm per pass. If you have used a planer thicknesser to smooth and dimension timber you will quickly learn to work with the drum sander, but do not over work it.



Be patient, let the drum sander do the work: 0.8mm or less per pass for best results.

The most common mistake made with a drum sander is forcing it to remove too much material too fast. Variables such as sandpaper grit, stock width, wood type, feed rate, and moisture content all influence how much material can be removed in a single pass.

### Double Pass

The maximum sanding width in a single pass is 255mm. When working with stock up to this width, the drum height lock should be engaged once the drum height has been set.

It is possible to work with stock up to 510mm wide by making 2 passes.

Firstly, remove the End Plate to make the end of the sander open.

Use a 13mm spanner to remove 2 bolts then remove the locking knob.

Wider stock can now be fed through the drum, with only the first 255mm being sanded. The stock can then be rotated 180 degrees and fed back into the sander with the remaining area being sanded to the same depth.

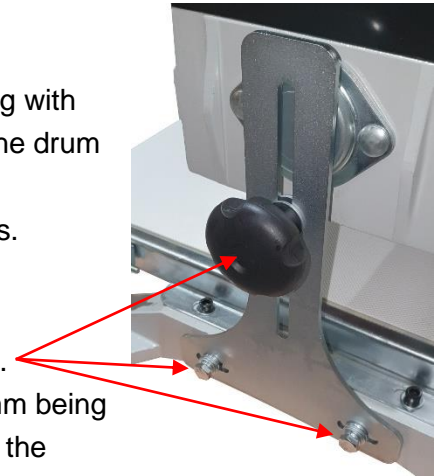

### Abrasive Grit Selection

Smoothing wood, or sanding, is the process of making finer and finer scratches until they become so small they are no longer visible to the human eye.

The grit size of the sandpaper designates the coarseness of the abrasive. The lower the grit number, the coarser the sandpaper and the larger the scratches made to the surface. Thus 80 grit sandpaper is coarser (bigger scratches) than 120 grit sandpaper, and 120 grit is coarser than 240 grit, and so on. With coarser grit papers, such as 80 grit, very aggressive material removal and surface scratching occurs, whereas with 240 grit, very little surface material is removed and a buffed like look begins to appear.

Typically, you begin sanding with a coarse grit and progressively work through finer grits until the desired finish or thickness is achieved. Choosing which grit to begin sanding with is a subjective judgment based on your assessment of stock condition (rough, smooth, etc.), thickness, hard/soft wood, and the desired outcome. Below are some general guidelines regarding sanding grits. Pre-cut wraps in each listed grit size are available.

GRIT	USES and ABRASIVE CHARACTERISTICS
80	Medium aggressive: stock removal, surfacing, glue removal, end grain smoothing, planer mark removal
120	Medium fine: light surfacing and stock removal, thin stock dimensioning
150	Fine: minimum stock removal, finish sanding surface preparation, thin stock dimensioning
180	Fine: finish sanding
240	Very fine: finish sanding

## **Drum Height**

The height of the drum is raised by turning the handwheel in a clockwise direction. To lower the drum, turn the handwheel in a counterclockwise direction. The depth of the movement is approximately 0.4mm per 1/4 turn in either direction. One complete turn is 1.6mm. Depth settings can be measured using the height reading scale. Depth settings used during surface sanding of stock are adjusted by considering several variables. The hardness of the material, the width of the material being surfaced, and the feed rate selected are all considered when determining the amount of material to be removed on each pass. Never remove more than 0.8mm of material in one pass.

## **Conveyor Feed Rate**

The variable feed rate is set to prevent burning and provide a smooth sanded surface on different types and widths of materials. As a general rule: 1/4 turn or 0.4mm or less is recommended stock removal for coarser grits and softer woods, while 1/8 of a turn or 0.2mm may be more desirable with harder woods and/or finer grits. Some experimenting and practice will be required to become familiar with the sanding performance of your Drum Sander.

When selecting the rate of feed for the material being surfaced:

Wider material - slow the feed rate.

Harder wood - slow the feed rate.

## **To Begin Sanding**

1. With power off, place stock on the feed table and advance the stock to a point so that you can adjust height of sanding drum to equal thickness of stock at its greatest point.
2. Connect and turn on the dust extractor.
3. Adjust feed rate to match sanding requirements and width of stock.
4. Turn on unit and place stock on the feed conveyor table allowing the feed belt to carry the stock into and engage the sanding action of the drum. Support long stock as necessary during the feed operation. Once the sanding operation feed allows, reposition yourself to the out feed side of the machine to accept, support, and control the board as it exits the Sander. NOTE: Do not apply upward or downward pressure when supporting and guiding stock through the sander. To do so may induce snipe (sander drum dig-in) into the sanded stock.
5. Reverse the feed direction of the stock on successive passes, while adjusting the depth of cut using the height adjustment hand wheel.

# Sanding Wrap Replacement

The most convenient way to buy sandpaper wraps is to use the precut type which come with the tapered ends ready to install.

The other option is to buy a roll of 82mm wide sandpaper and cut the tapers yourself.

The template below gives the dimensions for the tapers.

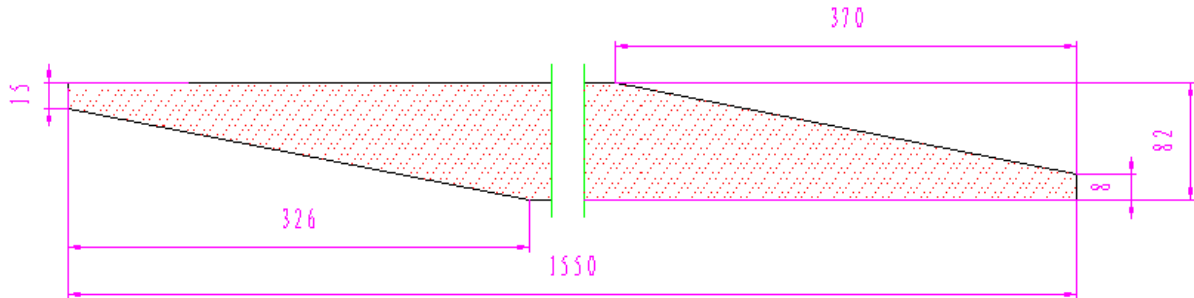

Left Clamp End

Right Clamp End



## To Change The Sandpaper Wrap

Disconnect from the power supply.

Identify the wider (15mm) end of the wrap.

Make a fold around 30mm in from the end.

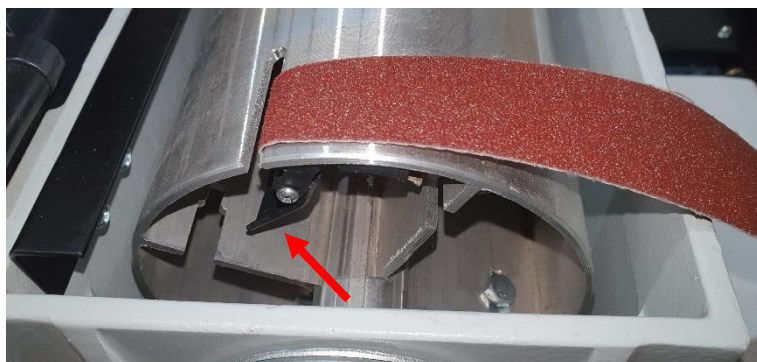

On the left side of the drum, press the spring loaded clip up towards the rim of the drum.

Insert the tip of the wrap through the slot in the drum and into the teeth of the clip.

Approximately 30mm of material should be inserted into the clip.

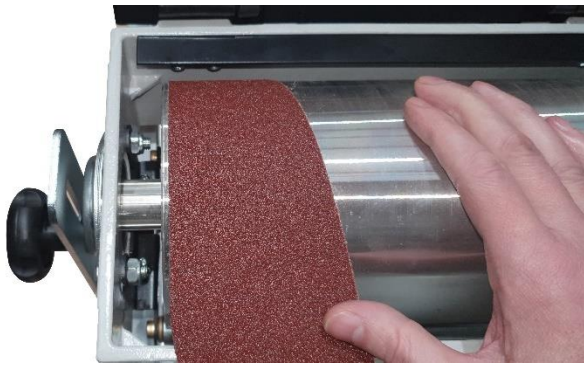

Stand in front of the drum and radially wrap the abrasive material.

Roll the drum away from you, whilst keeping some tension on the abrasive wrap and guide it onto the drum.

The edge of the taper should be parallel to the edge of the drum.



Continue along the length of the drum:

Do not let the sandpaper overlap, it should be flush or slightly gapped.



On the right hand end of the drum, press the clip and tensioning device towards the slot in the drum.



Insert the end of the wrap into the clip whilst keeping tension on the wound part of the wrap. When the clip is released it will grip the wrap and apply tension to it.



The tensioning device will hold tension in the event the wrap stretches during use.

TIP: The final part can be quite fiddly. You may find it helpful to place a wedge of timber into the open end of the drum to prevent it from rotating whilst inserting the tail end of the wrap.

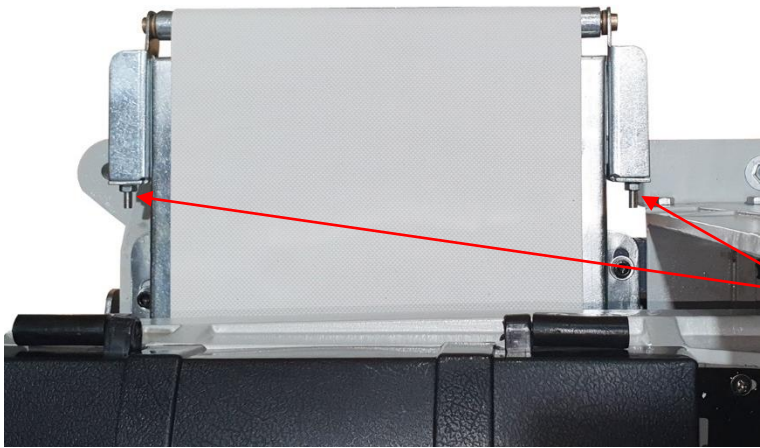
# Servicing And Maintenance

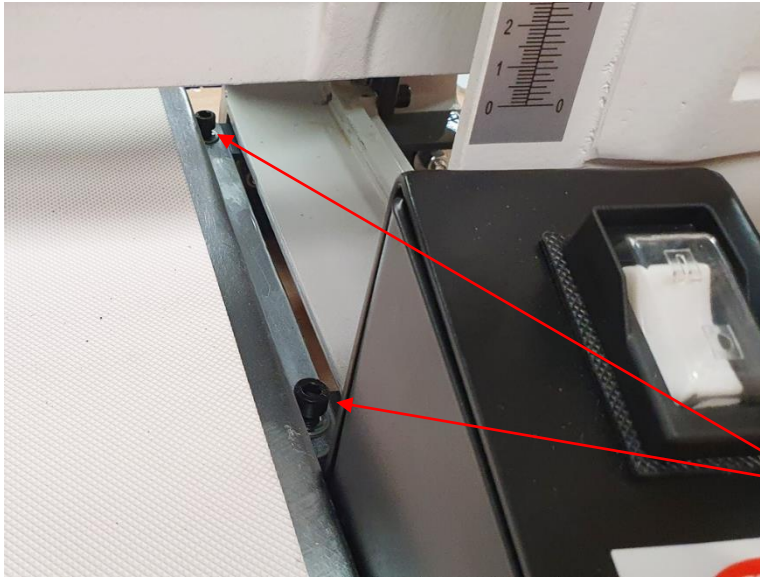
	<p><b>Conveyor Belt Tracking Adjustment</b></p> <p>Occasional adjustment of the conveyor belt tracking may be required due to belt stretching. Ideally, the conveyor feed belt should track in the center of the table.</p> <p>Adjustment nuts are located on both sides of the outfeed end of the conveyor. To adjust, use a 10mm spanner with the conveyor running at full speed.</p>
	<p>If the belt is tracking right, towards the motor side of the sander:</p> <p>Tighten the nut on the motor side and loosen the nut on the floating side.</p> <p>It may take a few moments to see the effect happening.</p>
	<p><b>Conveyor Belt Replacement</b></p> <p>The conveyor feed belt may need replacing after normal wear and tear.</p> <p>Disconnect from the power supply.</p> <p>Raise the sanding drum to its highest position.</p> <p>Remove the End Plate.</p> <p>Use a 6mm Allen key to loosen 2 bolts on the right side which secure the table to the sub frame.</p>



Use a 6mm Allen key to completely remove the 2 bolts on the open side which secure the table to the sub frame.

Reduce tension on the conveyor feed belt by rotating both the left and right belt tracking nuts in a counterclockwise direction.

Remove the used conveyor belt by grasping both sides of the belt. Gently lift the conveyor table as you slide off the conveyor belt.

If the belt will not move, further reduce the tension on the feed belt and ensure you are lifting the table high enough to allow the feed belt to slide off.

To install the replacement conveyor feed belt, follow the steps in reverse.

Center the new belt on the table and evenly tension the belt using the left and right tracking adjusters.

Remove 2 Bolts



### Excess Movement in the Floating End of the Drum

If movement is detected, check the tightness of the 2 Clamp Bolts.

Adjusted the bolts to allow smooth height adjustments, while ensuring a tight enough fit to limit drum deflection. If the screws are too loose, the drum will deflect during use, causing an uneven sanding surface. If the screws are too tight, sanding drum height adjustments will be difficult.

To adjust the screws, use a 6mm Hex Key and 13mm spanner. Loosen or tighten each bolt, as required, in 1/8 turn increments to attain the desired fit and smoothness.

## Troubleshooting

Problem	Cause	Remedy
Machine does not start	Thermal Overload has tripped	Wait for motor to cool down
	Faulty switch	Replace switch
Only starts when Green button is held down	Faulty switch	Replace switch
MCB trips on Start up	Short circuit in cable or plug	Repair the damage
Machine hums but does not start	Start capacitor failed	Replace start capacitor
Motor running but drum is not rotating	Broken or coupling or spider	Inspect and replace rubber spider
Motor slows down during the cut	Depth of cut is too great	Take a smaller cut
	Dust & Chip collector hood is blocked	Clear the blockage and ensure the extractor is functioning correctly

Conveyor belt slipping	Build up of dust and sap on the belt	Clean the belt
	Insufficient tension on belt	Increase tension on belt
	Rubber drive roller is worn out	Replace drive roller
Long lines or ridges along the length of planed timber	Damaged sanding wrap	Re-wrap or replace the sandpaper
Conveyor running, but speed not changing	Failed PCB	Replace the PCB inside the switch housing

## Declaration of Conformity for CE Marking

Charnwood Declare that Woodworking Drum Sander, Model DS10/20

Conforms with the following EU Directives: Machinery Directive 2006/42/EC  
Electromagnetic Compatibility Directive 2014/30/EU  
Conforms with the following UK Regulations: Supply of Machinery (Safety) Regulations 2008  
Electromagnetic Compatibility Regulations 2016

And further conforms to the machinery example for which the EC type examination Certificate No. TA 385213771 & AE 50390138 have been issued by TUV Rheinland LGA Products GmbH, Tillystrasse 2, 90431, Nurnberg, Germany.

I hereby declare that equipment named above has been tested and found to comply with the relevant sections of the above referenced specifications. The machinery complies with all essential requirements of the directives and regulations.

Signed:   
Richard Cook, Director

Dated: 04/01/2023

Location: Leicestershire



Please dispose of packaging for the product in a responsible manner. It is suitable for recycling. Help to protect the environment, take the packaging to the local amenity tip and place into the appropriate recycling bin.



Only for EU countries

Do not dispose of electric tools together with household waste material!

In observance of European Directive 2002/96/EC on waste electrical and electronic equipment (EEE) and its implementation in accordance with national law, electric tools that have reached the end of their life must be collected separately and returned to an environmentally compatible recycling facility.

Your local refuse amenity will have a separate collection area for EEE goods



# Charnwood DS10/20 Parts Diagrams

Drawing A:

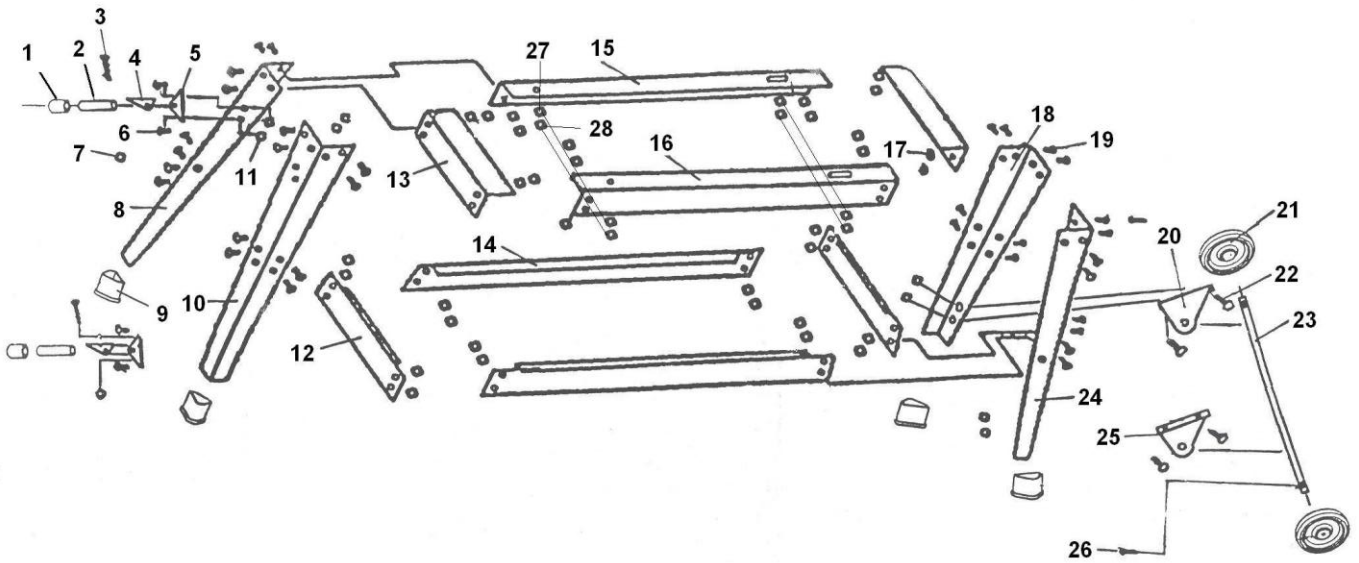

Part Number	Description	Quantity
A01	Handle Sleeve	2
A02	Handle	2
A03	Screw M4 X 35	2
A04	Support Base	2
A05	Fixing Base	2
A06	Screw M6 X 10	4
A07	Hex nut M4	2
A08	Front Stand(left)	1
A09	Front Stand(right)	4
A10	Front stand(right)	1
A11	Hex Nut M6	4
A12	Short Cross Stand	2
A13	Short Support Plate(left)	2
A14	Long Cross Stand	2
A15	Long Support Plate(right)	1
A16	Long Support Plate(right )	1
A17	Hex Nut M8	36
A18	Rear Stand(left)	1
A19	Bolt M8 X 12	32
A20	Wheel Mounting Base	1
A21	Wheel 5"	2
A22	Hex Bolt M8 X 16	4
A23	Wheel Shaft	1
A24	Back Stand(right)	1
A25	Wheel Mounting Stand	1
A26	Pin 4 X 20	2

Drawing B:

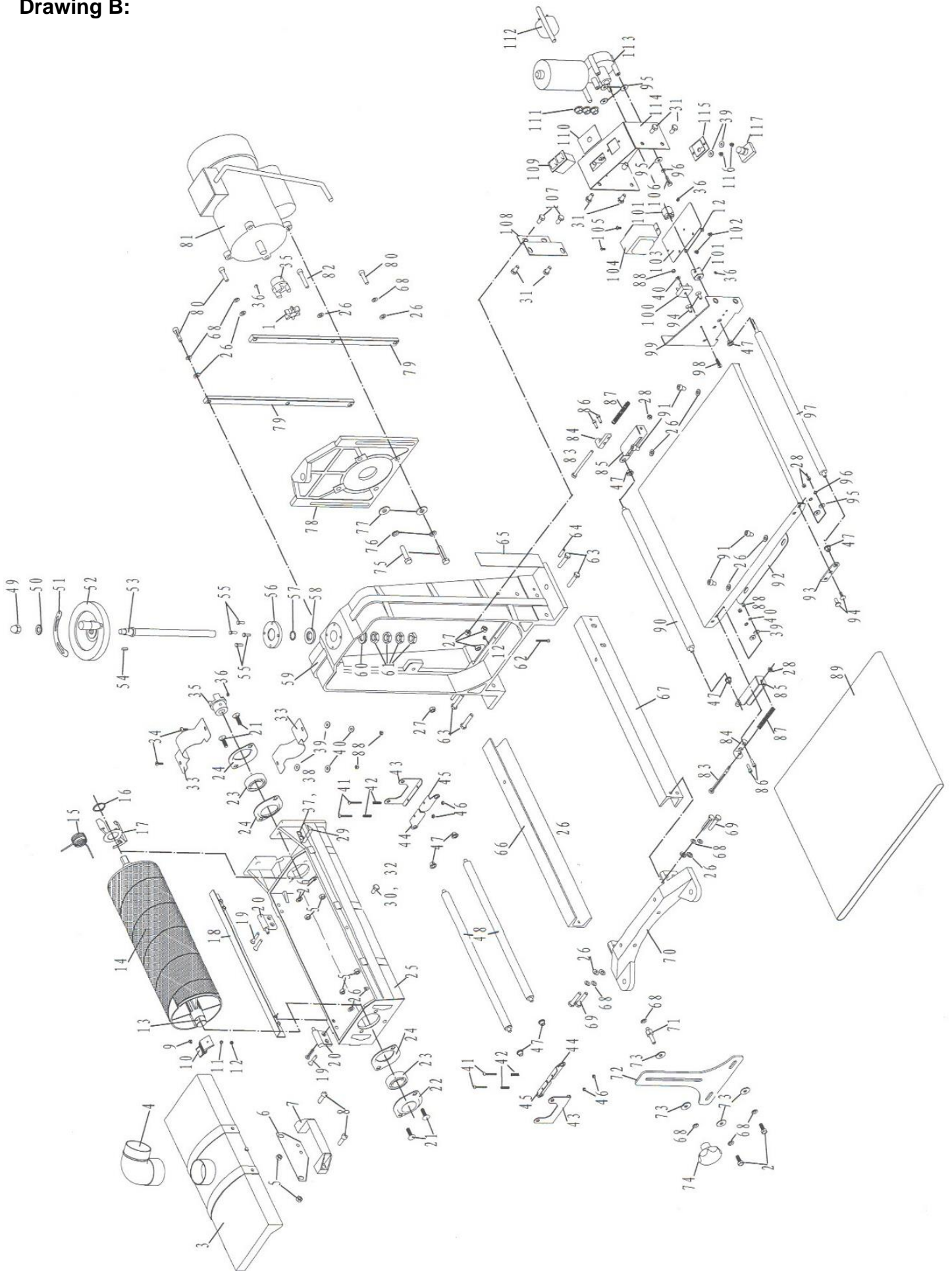

Part No.	DESCRIPTION	QTY	Part No.	DESCRIPTION	QTY
B001	Rubber Spider	1	B043	Drum Seat	2
B002	Bolt M8 x 20	4	B044	Left Roller Seat	2
B003	Drum Cover	1	B045	Right Roller Seat	2
B004	90°Elbow	1	B046	Nut M4	4
B005	Nut	6	B047	Roller Bush	8
B006	Locking Plate	1	B048	Drum Roller	2
B007	Handle	1	B049	Special Nut M12	1
B008	Bolt M8 x 25	2	B050	Washer M12	1
B009	BOLT M4 x 8	1	B051	Direction Label	1
B010	Left Spring Clamp	1	B052	Hand Wheel	1
B011	Spring Washer 4	1	B053	Rise & Fall Shaft	1
B012	Nut M4	1	B054	Shaft Key	1
B013	Sanding Drum	1	B055	Bolt M5 x 16	4
B014	Sanding Warp	1	B056	Cover	1
B015	Clamp Spring	1	B057	Sleeve	23
B016	Sring Ring 28	1	B058	Sleeve	1
B017	Right Spring Clamp	1	B059	Column	1
B018	Deflector Strip	1	B060	Washer	1
B019	Bolt M6 x 30	4	B061	Nut M16 x 1.5	4
B020	Hinge	2	B062	Bolt M4 x 35	1
B021	Screw M8 x 25	4	B063	Bolt M8 x 40	4
B022	Bearing Seat	1	B064	Spring Pin 6 x 26	2
B023	Bearing 6205	2	B065	Scale	1
B024	Bearing Seat	3	B066	Rear Bracket	1
B025	Drum Housing	1	B067	Front Bracket	1
B026	Washer M8	22	B068	Spring Washer M8	15
B027	Nut M8	4	B069	Bolt M8 x 25	4
B028	Nut M6	6	B070	Left Base	1
B029	Pointer	1	B071	Shaft	1
B030	Bolt M6 x 14	1	B072	End Plate	1
B031	Screw M8 x 16	6	B073	Washer M8	4
B032	Washer M6	1	B074	Locking Knob	1
B033	Coupling Guard	2	B075	Bolt M10 x 40	4
B034	Bolt M5 x 16	2	B076	Spring Washer M10	4
B035	Coupler	2	B077	Washer M10	4
B036	Bolt M6 x 8	2	B078	Motor Seat	1
B037	Bolt M4 x 10	2	B079	Guide Strip	2
B038	Washer M4	2	B080	Bolt M8 x 30	4
B039	Washer M5	8	B081	Motor 240v	1
B040	Spring Washer M5	7	B082	Screw M8 x 45	2
B041	Screw M4 x 30	4	B083	Bolt M6 x 90	2
B042	Spring	4	B084	Sliding Block	2
			B085	Spring Housing	2

Part No.	DESCRIPTION	QTY	Part No.	DESCRIPTION	QTY
B086	Bolt M5 x 16	4	B101	Coupler	2
B087	Spring	2	B102	Bolt M5 x 10	2
B088	Nut M5	7	B103	Plate	1
B089	Conveyor Belt	1	B104	Transformer	1
B090	Rear Conveyor Roller	1	B105	Bolt M4 x 10	2
B091	Bolt M8 x12	4	B106	Screw M6 x 20	3
B092	Table	1	B108	Connecting Plate	1
B093	Support Plate	1	B109	On/Off Switch KJD16	1
B094	Bolt M6 x 16	4	B110	Label	1
B095	Washer M6	10	B111	Clamp	3
B096	Spring Washer M6	7	B112	Cable & Plug	1
B097	Front Conveyor Roller	1	B113	Conveyor Motor & Gear Box	1
B098	Bolt M5 x 20	1	B114	Switch Box	1
B099	Inner Cover	1	B115	Insulation Block	1
B100	Circuit Board	1	B116	Bolt M5 x 6	2
			B117	Speed Controller	1
			CAP	Capacitor 25uf 450V	1

## DS10/20 WIRING DIAGRAM

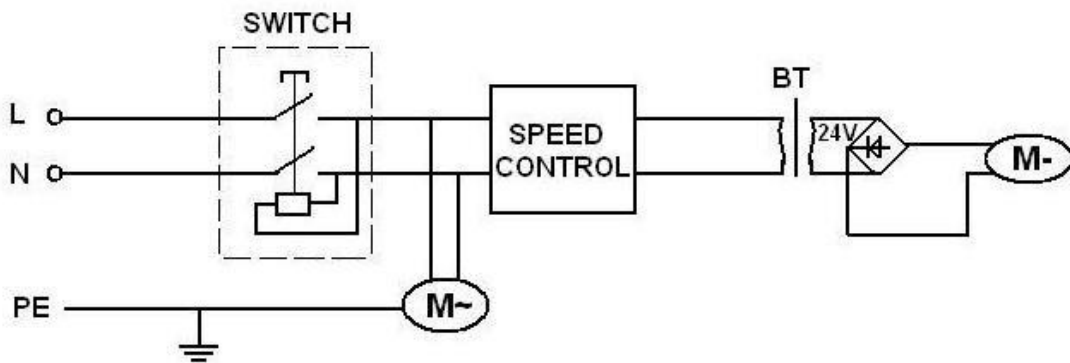

*Woodworking machinery at its best!*

Last Updated January 2023

Charnwood Machinery, Cedar Court, Walker Road, Hilltop Industrial Estate,  
Bardon, Leicestershire, LE67 1TU

Tel. 01530 516 926

email: [sales@charnwood.net](mailto:sales@charnwood.net)

website: [www.charnwood.net](http://www.charnwood.net)