



Woodworking machinery at its best!

**8" TABLE SAW WITH PRECISION RIP FENCE
OWNERS MANUAL**

MODEL: W619PSF



**Charnwood, Cedar Court, Walker Road,
Hilltop Industrial Estate, Bardon Hill, Leicestershire, LE67 1TU**

**Tel. 01530 516 926 Fax. 01530 516 929
email: sales@charnwood.net website: www.charnwood.net**

GENERAL SAFETY RULES



WARNING: Do not attempt to operate the machine until you have read thoroughly and understood completely all instructions, rules, etc. contained in this manual. Failure to comply may result in accidents involving fire, electric shock, or serious personal injury. Keep this owner's manual and review frequently for continuous safe operation.

Know your machine. For your own safety, read the owner's manual carefully. Learn its application and limitations, as well as specific potential hazards pertinent to this machine.

1. Make sure all tools are properly earthed.
2. Keep guards in place and in working order. If a guard must be removed for maintenance or cleaning, make sure it is properly replaced before using the machine again.
3. Remove adjusting keys and spanners. Form a habit of checking to see that the keys and adjusting spanners are removed from the machine before switched it on.
4. Keep your work area clean. Cluttered areas and workbenches increase the chance of an accident.'
5. Do not use in dangerous environments. Do not use power tools in damp or wet locations, or expose them to rain. Keep work areas well illuminated.
6. Keep children away. All visitors should be kept a safe distance from the work area.
7. Make workshop childproof. Use padlocks, master switches and remove starter keys.
8. Do not force the machine. It will do the job better and be safer at the rate for which it is designed.
9. Use the right tools. Do not force the machine or attachments to do a job for which they are not designed. Contact the manufacturer or distributor if there is any question about the machine's suitability for a particular task.
10. Wear proper apparel. Avoid loose clothing, gloves, ties, rings, bracelets, and jewellery which could get caught in moving parts. Non-slip footwear is recommended. Wear protective hair covering to contain long hair.
11. Always use safety glasses. Normal spectacles only have impact resistant lenses. They are not safety glasses.
12. Do not over-reach. Keep proper footing and balance at all times.
13. Maintain the machine in good condition. Keep the machine clean for best and safest performance. Follow instructions for lubrication and changing accessories.
14. Disconnect the machine from power source before servicing and when changing the blade.
15. Never leave the machine running unattended. Turn the power off. Do not leave the machine until it comes to a complete stop.
16. Do not use any power tools while under the effects of drugs, alcohol or medication.
17. Always wear a face or dust mask if operation creates a lot of dust and/or chips. Always operate the tool in a well ventilated area and provide for proper dust removal. Use a suitable dust extractor.

ADDITIONAL RULES FOR CIRCULAR SAWS

1. Ensure that the saw table is clear of off-cuts, tools or anything else that might foul the work-piece.
2. If your saw has a dust extractor hose connected to the crown guard, ensure that it is held clear of the table and will not foul the work-piece as it passes over the table.
3. When cutting large sheets of material or long boards use one or more roller stand(s) to support the work or have a competent helper to support it as it feeds off the rear of the table.
4. Never use the saw without the riving knife and check that it is in line with the blade before using the saw.
5. Always use a brush to clear the table of dust or debris. NEVER use your hands, especially when the machine is running.
6. ALWAYS USE A PUSH STICK WHEN IT IS NECESSARY TO PUSH ANY PIECE OF MATERIAL OF SUCH SIZE THAT IT WOULD BRING YOUR HANDS WITHIN 30 CM OF THE BLADE.
7. Do not cut material that is badly warped or which has screws or nails in it

8. Be extra vigilant when cutting stock which has loose knots in it as these may fly out of the saw.
9. NEVER remove the table insert when the saw is running.
10. To avoid exposure to hazardous dust, do not use this saw without connecting it to a suitable dust extractor.
11. Always work with a sharp saw blade and feed the work at a rate suited to the thickness and hardness of the material.

Note: This table saw has been designed and built solely as a woodworking machine. Do not modify it in any way or use for anything other than its designated purpose. Neither the manufacturer nor the supplier are liable for any damage or injury caused by incorrect assembly, operation or electrical connection of this machine.



Risk of Injury!
Never reach into
the running saw blade.



Wear Eye
Protection



Wear Ear
Protection

Specification

Table size	530 x400mm
Table size with extensions	530 x 1000mm
Motor (Induction)	1100W (1.5hp) 240v
Blade diameter x bore	200mm x 30mm
Blade rotation speed (no load)	4000 rpm
Maximum depth of cut at 90/45 degrees	60mm / 47mm
Cutting width with table extension	730mm
Mitre Guide 'T' Slot Width	15/19mm
Dust extractor hose connection	100mm
Weight - Nett/Gross	80/100kg
Rating	Light Trade

Rating Description

Light Trade: Suitable for professional woodworkers where the machine will not be in daily use.

Mid range machines with a heavier build and more power. Typically used by 2 or 3 people within a small business and also for the dedicated hobbyist with a larger budget. It is expected to be used up to the machine's maximum limit with occasional long work periods. Suitable for income generation. Expected maximum use of 300 hours annually.

Unpacking



This product is packed into 3 parts;
1 wooden crate and 2 cardboard cartons.

To open the wooden crate, cut the strapping
and lift the lid of the crate up from the base.



Remove the plastic cover and the items
packed loosely around the base.

Use a cross head screwdriver to remove 4
screws, then remove the blue side panel
which has the tilt arbor shaft protruding
through it.

Remove items packed inside.



The machine is fixed to the base with two
bolts.

Use a 10mm spanner to undo the 2
securing nuts.

This part of the assembly requires 2 people:

Flip the body of the saw upside down.

Identify The Loose Parts

Rear Table Support Rail Cross Cut Fence Fence Carrier Extrusion Owner's Manual & Tools Extension Tables Sliding Carriage Guide Rail

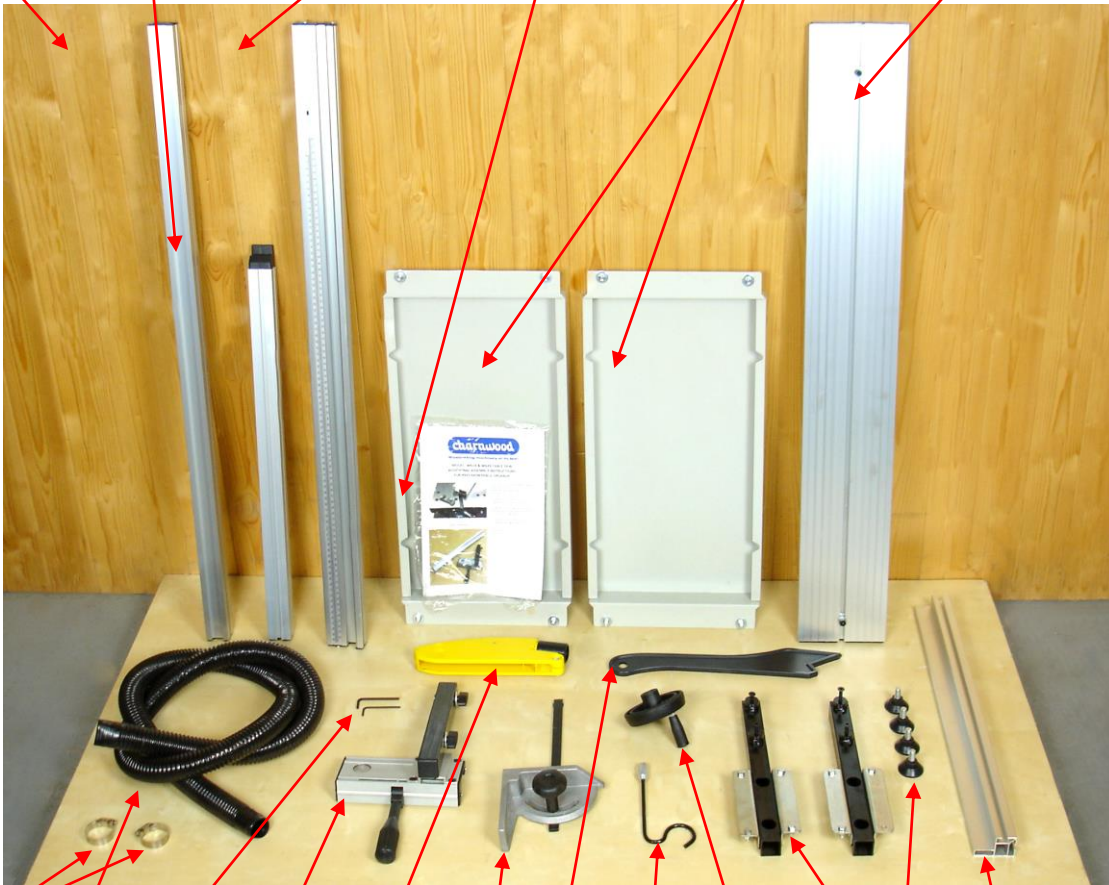

Hose Clips Allen Keys Crown Guard Push Stick Tilt Handwheel Feet Rip Fence
 Dust Hose Rip Fence Bracket Mitre Fence Hose Support Rail Supports

Hold Down Clamp Clamp/Fence Bracket Sliding Table with Rollers

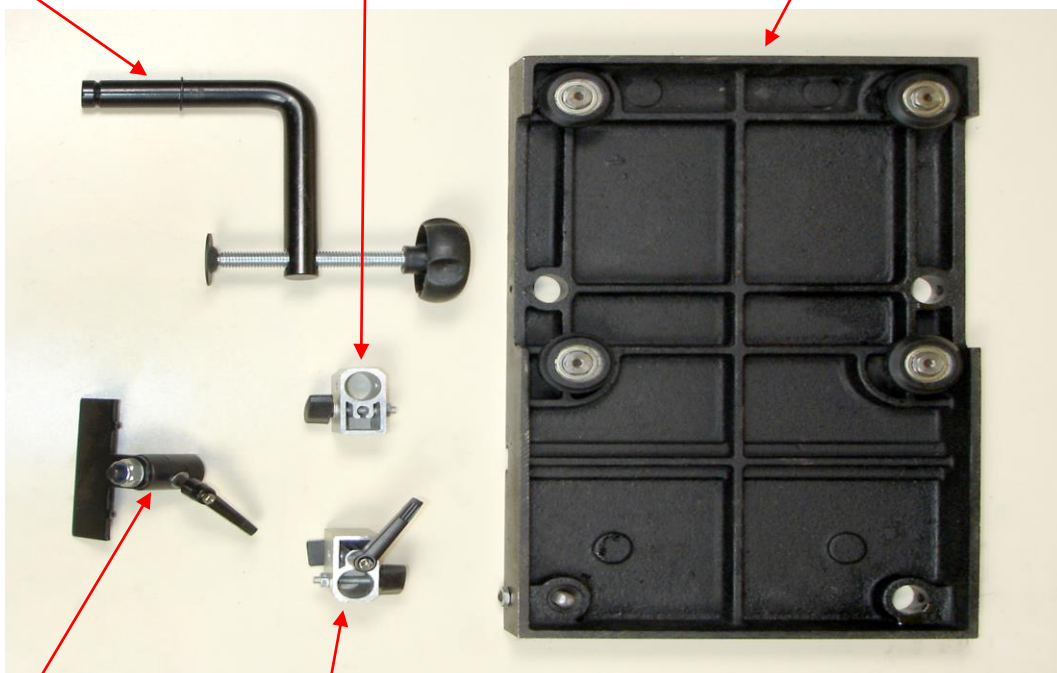

Length Stop Adjustable Fence Bracket

Assembly

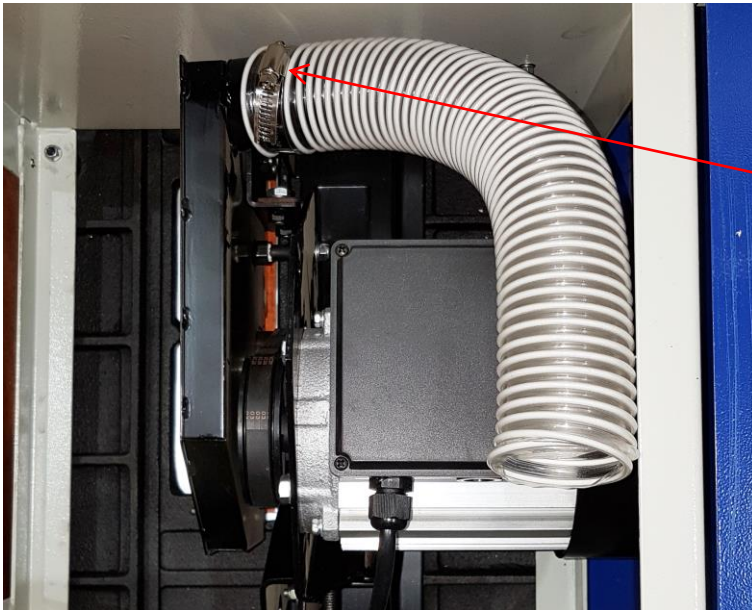

With the body of the saw upside down.

Attach one end of the 50mm diameter hose to the dust hood.

Secure it with a hose clamp.



To assemble the base.

Locate:

4 Panels

4 Feet

12 x M6 Bolt, Washer and nut



Screw the 4 feet into the threaded holes in the 2 side panels of the base.

Use a 17mm spanner to tighten them.

After full assembly of the machine, the feet can be adjusted to level up the machine.



Use 12 of the M6 bolts, washers and nuts to join the 4 panels together.

Leave all 12 bolts finger tight for now.

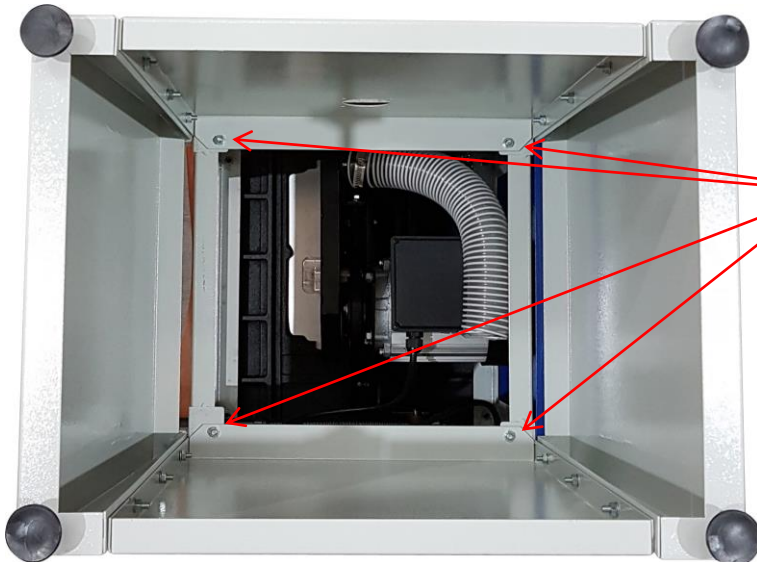

Invert the assembled base and mount it onto the upturned body of the machine.

Use the remaining 4 x M6 bolt, washer and nut to attach the base to the saw body.

Tighten with a 10mm spanner.

Now tighten up the remaining 12 nuts and bolts of the base with a 10mm spanner.



Attach the dust collection port to the base, so that the 100mm diameter outlet is on the outside of the base.

Rotate the collection port so that the small inlet is pointing away from the On/Off switch. (pointing to the right, once the saw is upright)

Secure using 4 x bolt, washer and nut.

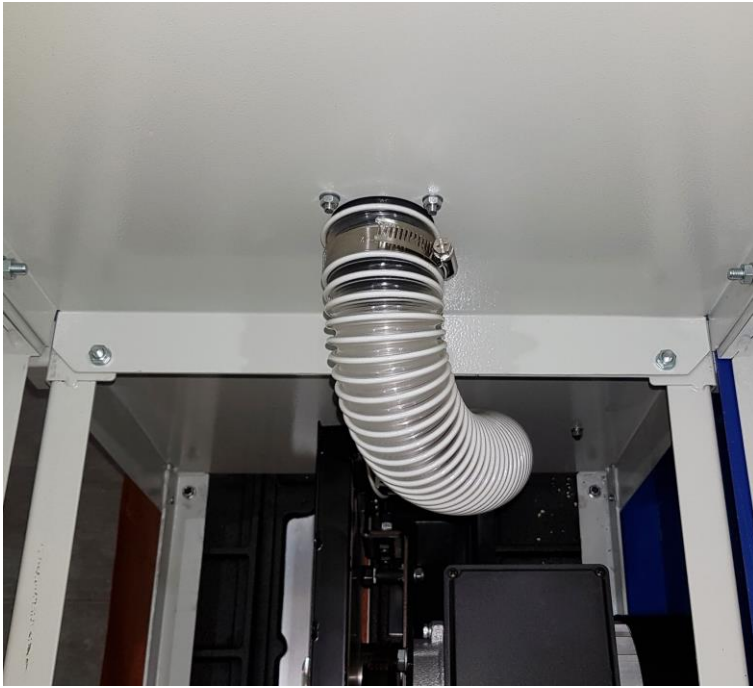

Attach the other end of the 50mm diameter hose to the inside of the dust collection port and secure with a hose clamp.

This part of the assembly requires 2 people: Return the saw to an upright position.

Remove the protective covering from the cast iron table. The table is coated with a layer of grease to prevent rust. This is easily removed with a soft cloth moistened with paraffin or WD40.



Raise the saw blade by turning the fitted hand wheel at the front of the machine clockwise.

Fit the other hand wheel from the bag of components to the spindle on the right hand side of the saw. Tighten the grub screw so that it engages with the flat on the spindle.

Turn the wheel clockwise until the blade is vertical, if it is not already in this position.

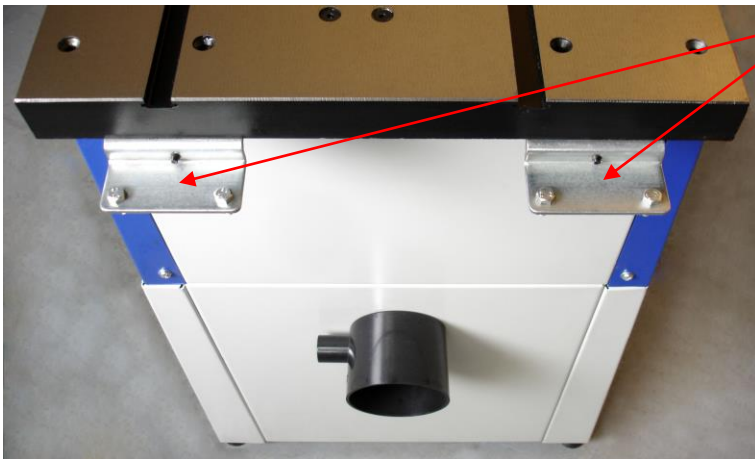

There are two brackets at the rear of the saw.

Each one has two hex headed bolts and nuts passing through it.

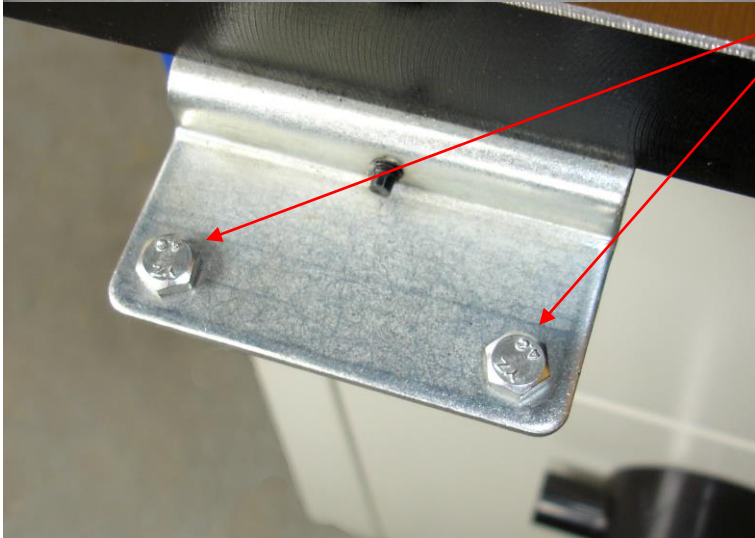

Loosen the nuts and lifting each bolt head in turn, slide the 100cm long square aluminium extrusion over them.



The rear table support extrusion should be fitted to the rear with the open side facing outwards.

If it is difficult to slide on, make sure that you have slackeden the nuts sufficiently and rock the extrusion gently as you move it along.

You may need to reach round to the back of the brackets and unscrew the black adjusters a little, if they are binding on the aluminium.



End Cap

M6 Bolts

Remove the end cap from the left hand end of the front rail. Loosen the three M6 bolts in the front flange of the saw table.

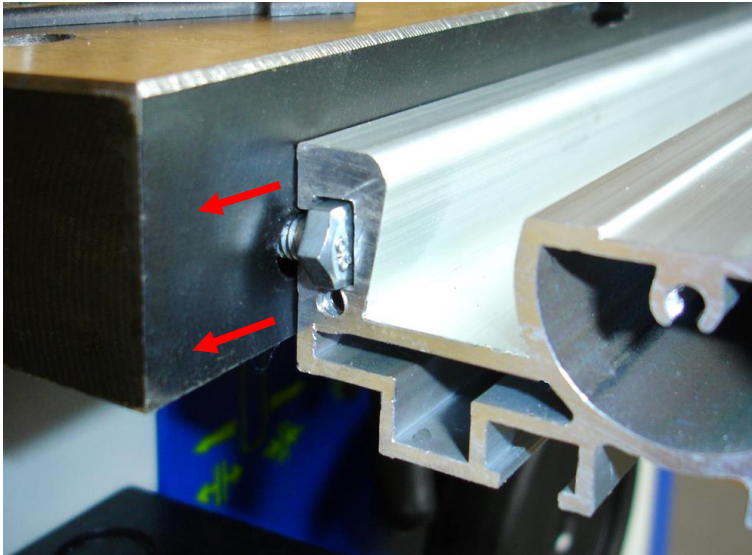

Slide the front rail over the three bolt heads and hand tighten the nuts ensuring that the rail can still slide.



Identify the Rip Fence Carrier and the Fence Extrusion.



Undo the 2 wing nuts on the fence carrier until the fence extrusion can slide over the square head bolts as shown.

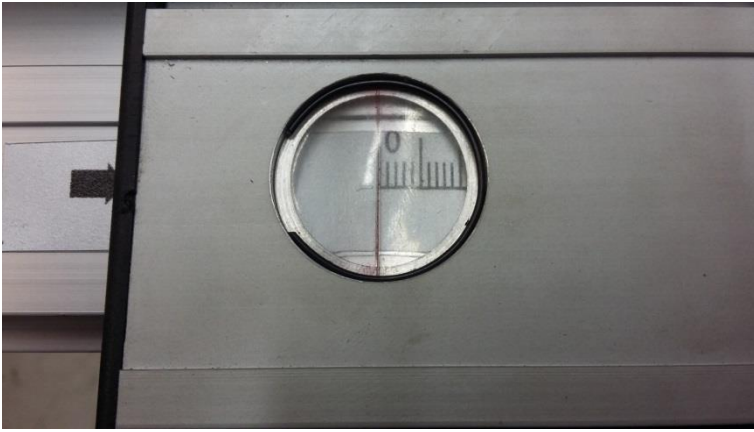

Set the rip fence onto the front rail so that the scale reads Zero.

Press down the front handle to lock it in place.



Slide the front rail, with the rip fence attached, so that the vertical face of the fence is touching the saw blade.

Now fully tighten the 3 fixing nuts.

Refit the plastic end cap to the front rail.

The rip fence can be assembled in two different ways; High and Low.

The standard assembly is in the High position.

The low position is used when making narrow cuts and allows the fence to get closer to the blade without fouling on the crown guard.

There is a dual scale on the front rail depending on which way the fence is being used.

Take care to read off the correct scale.

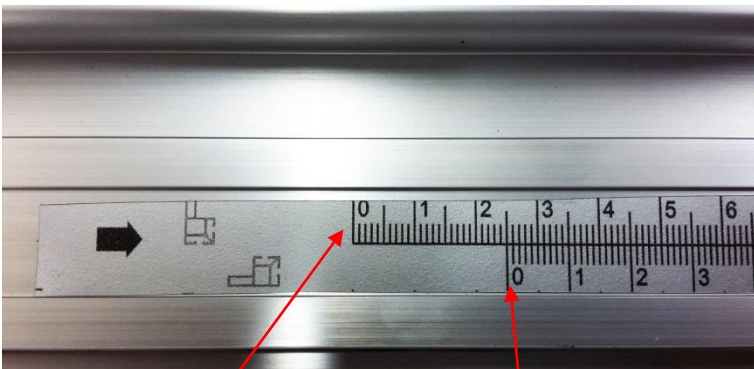

High Fence Scale

Low Fence Scale

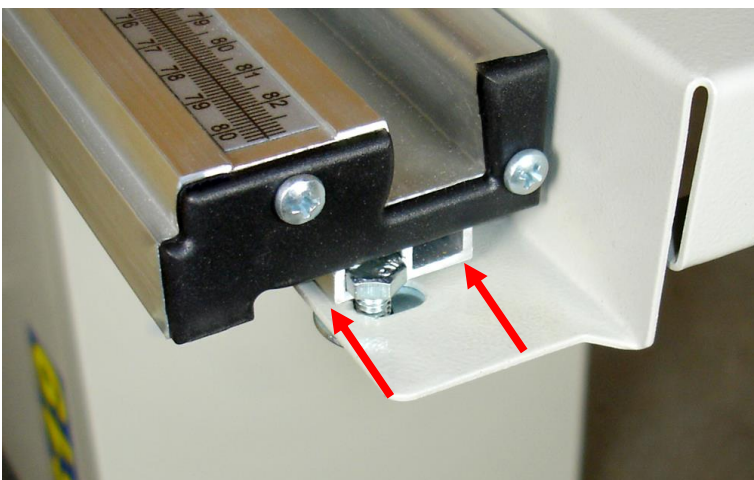

Take the first of the extension tables, loosen the four nuts & bolts and slide their heads into the bottom channels of the front & rear rails.

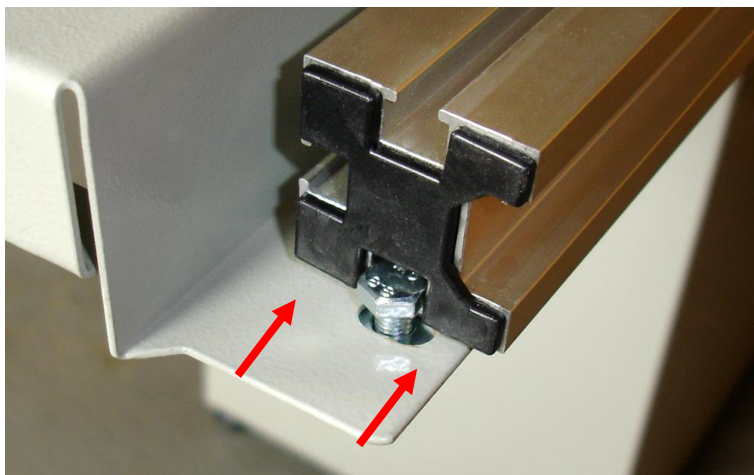

Add the second extension and, ensuring the tops of the tables are all level, re-tighten the eight bolts.



Clip the saw guard to the riving knife and tighten the bolt sufficiently to hold it the set position while still allowing adjustment.

Slide the hose support clip onto the rear guide rail and lock it into place.

Fit the dust collection hose to the saw guard and the spigot on the rear extraction point. Secure in place with the two hose clamps provided.

Clip the hose into the support arm to hold it clear of the table.

It is strongly recommended you use a dust extractor at all times, by connecting a hose to the 100mm outlet.

Failure to use an extractor will require stopping the machine regularly to clean out the internal parts of the extraction hood, to avoid causing damage and prolong the life of the blade.

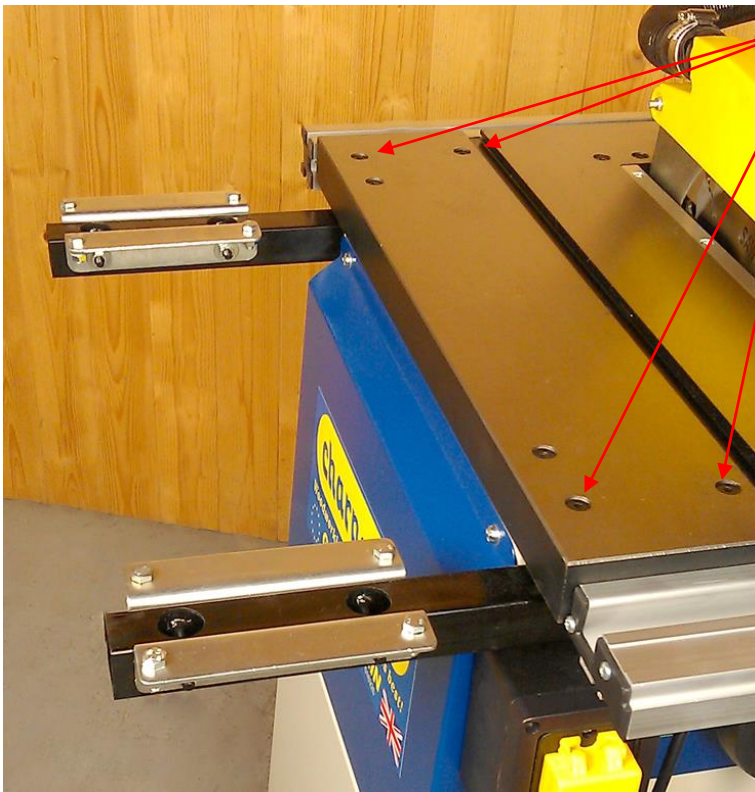

Fit the two support arms which will carry the guide rail for the sliding carriage. These are bolted to the left hand side of the table with four countersunk bolts

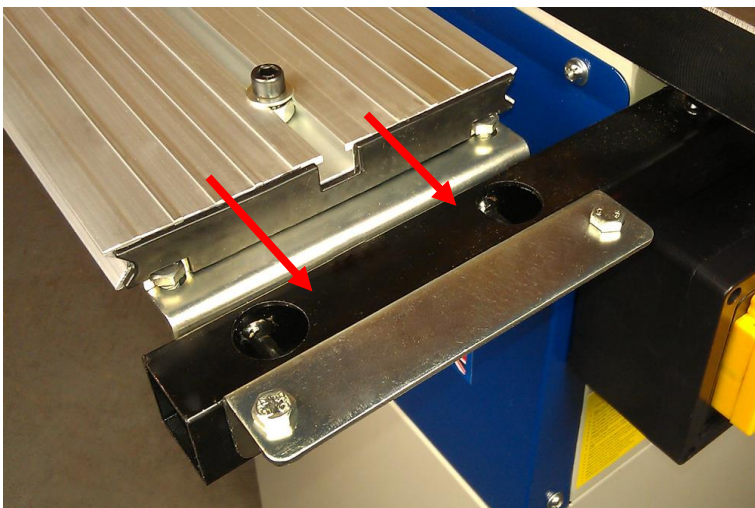

Fit the wide guide rail extrusion by sliding it over the heads of the eight securing bolts.

Position the sliding carriage guide rail so that the back edge of the rail is level with the back side of the rear support rail.

Ensure the guide rail is parallel to the saw blade before tightening the eight nuts.

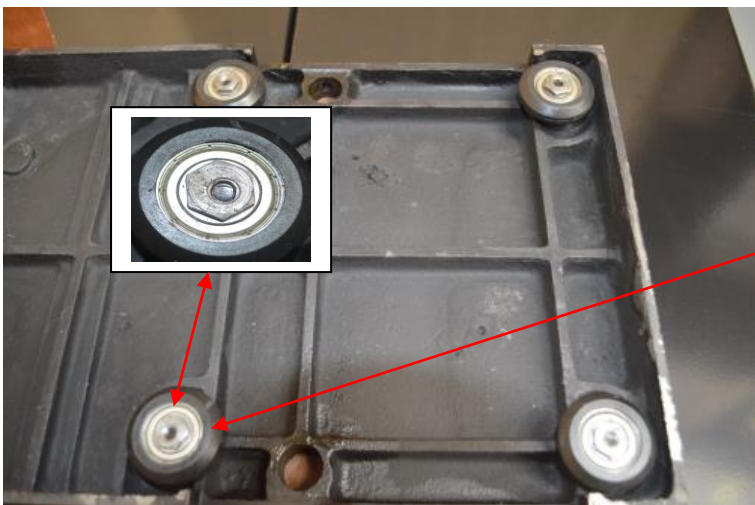

Before fitting the sliding carriage, it should be noted that the two outboard bearing wheels are mounted on eccentric holes.

Should it ever be necessary, any wear to the carriage can be adjusted with the aid of a 14mm spanner.

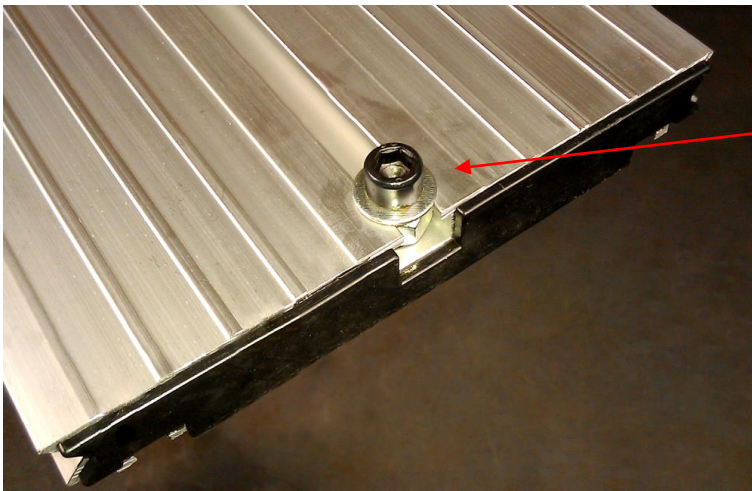

The guide rail is fitted with front and rear travel stops.

Move the rear travel stop to the back of the slot.

Remove the front stop completely and fit the sliding carriage onto the guide rail so that the four bearing guides are located in the matching grooves along the sides of the rail.

Replace the front stop.

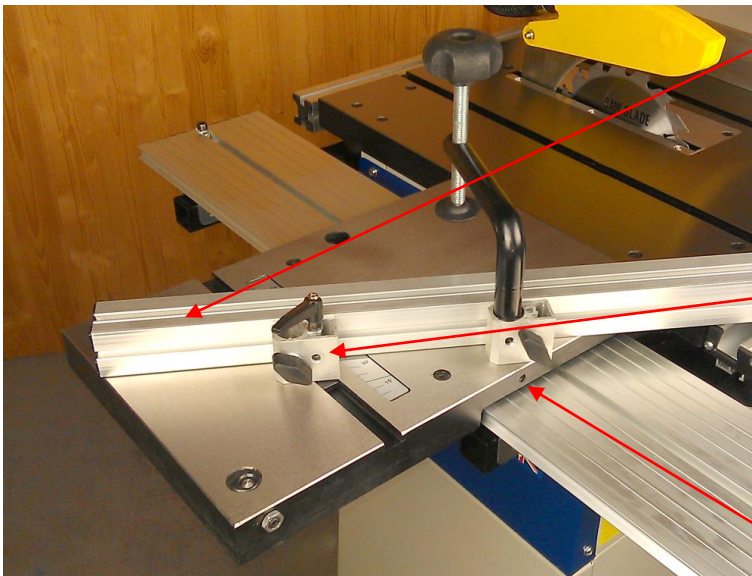

Identify the crosscut fence. Place it with the open side, face down and the plastic tip to the right.

Slide the pivot block and the locking block onto the back side of the fence with the head of the bolt in the T-slot.

The Locking block has a T-shaped foot plate, slide it into the slot in the sliding carriage table.

The Work clamp passes through the pivot block and locates in the large hole at the front of the carriage.

The work clamp should be locked in place using a small grub screw in the front edge of the carriage.



Fit the flip-over length stop by feeding the head of the bolt into the T-shaped slot on the top side of the fence.

The ratchet handle locks the stop in place.

The stop plate can be flipped over to engage or disengage it.



From underneath the carriage, push up the locating stop.

Use a square to check the crosscut fence is set at 90 degrees to the blade.

If necessary, adjust the stop by loosening the locking ring and grub screw. Put a screwdriver into the slot to rotate the stop to set the angle.

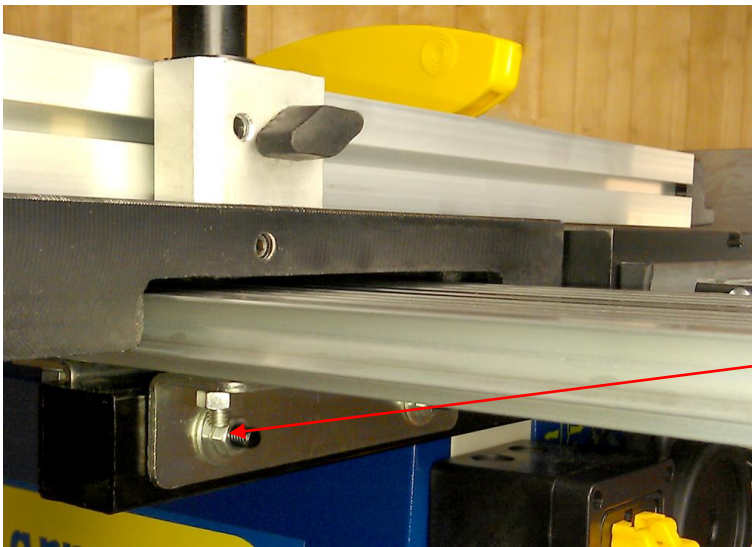

Check the Sliding carriage table is level to the main table. It should be level or slightly higher (up to 1mm) than the main table to allow a clamped work piece to move across the main table.

If necessary, loosen and adjust the four silver support brackets to lift or level the sliding carriage.

All four nuts holding the brackets on each arm need to be loose when making an adjustment.

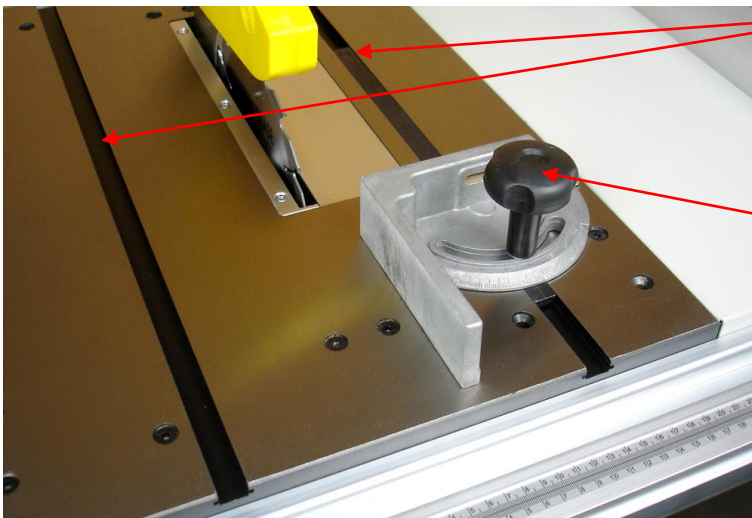

The sliding mitre fence can be used on either side of the blade.

Slide the T-shape bar in the slot in the main table.

The large knob is used to unlock the angle, which can be read from the scale on the front.

Riving Knife Adjustment

To fit inside the packing crate, the riving knife is set by the factory in a lower position which restricts the cutting depth of the table saw. Follow these instructions to raise the riving knife and use the full 60mm cutting depth.



Ensure that the machine is isolated from the power supply.

Raise the blade to its maximum height using the blade height adjustment hand wheel at the front of the saw.

Remove the two countersunk screws from the right-hand part of the table insert using a 4mm hex key. Lift out the insert



The two bolts holding the riving knife can now be loosened using a 13mm spanner.

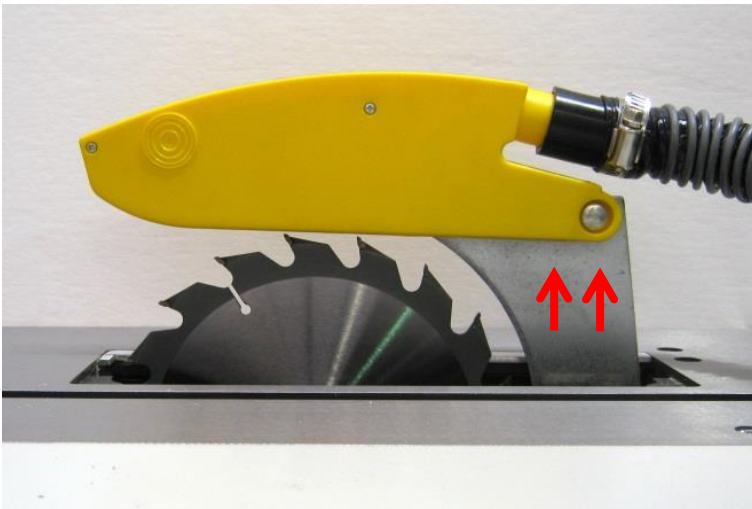

Raise the riving knife and crown guard assembly, so that the crown guard is situated just above the top of the saw blade. If necessary adjust the riving knife so that there is an even gap of around 5mm between the curved leading edge of the knife and the radius of the saw blade.

Adjust the crown guard so that it is parallel to the table.

Re-tighten the two bolts. Replace the table insert and screws.

The saw can now be used to cut at full capacity.

Using The Table Saw

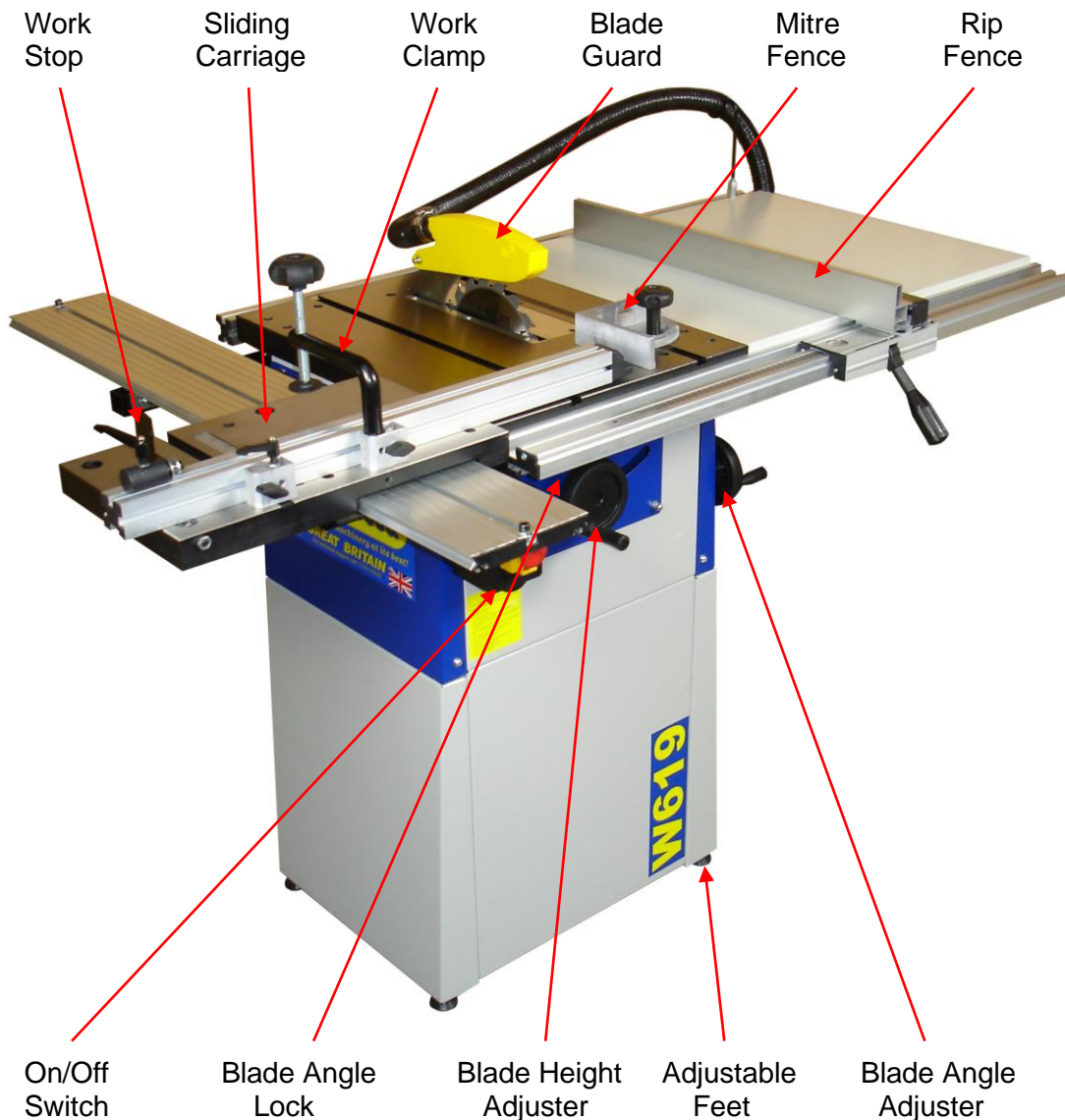

On/Off Switch

Slide the red section upwards and then lift the hinged cover. This will give you access to the green start and red stop buttons. Pressing the red section of the cover will stop the saw.

To turn the saw on, press the green button. Wait for the blade to reach its maximum speed of rotation before commencing with the cut.

The machine is fitted with an NVR (No Voltage Release) switch. This type of switch is designed so that if the machine is disconnected from the mains whilst running and then reconnected, the motor will not automatically restart.

Blade Height

Adjustments to the blade height should be made only when the saw is not running.

Turn the round hand wheel on the front, to set the blade to the required depth. Turn anticlockwise to lower the blade, turn clockwise to raise the blade. The blade height should always be set so that only the carbide tips of the blade (approx. 5mm) projects above the wood.

Blade Angle

Adjustments to the angle of cut should be made only when the saw is not running.

To tilt the blade for making bevel cuts, undo the blade angle lock, rotate the hand wheel to the required angle using the scale provided for guidance. Lock the angle by pressing down the locking lever.

Making A Cut

Ensure there is enough space around the table for the work piece before starting the cut. Position your feet in a stable and balanced stance.

When feeding the timber, place your hands on the section of timber being kept. Never hold the waste part of the timber.

Never force timber through the saw, always let it cut at its own speed.

When cutting narrow pieces - use a push stick.



Ripping Cut

The rip fence is used to make longitudinal (with the grain) cuts. Set the fence to the required dimension using the scale provided.

To avoid kickback, the far end of the fence extrusion should be set correctly.

When cutting narrow pieces, the fence extrusion should be set so that the end is level with the centre of the saw blade. This allows the timber space to expand into, after the cut has been made.

When cutting wider pieces, the fence extrusion can be moved further towards the back of the blade, in a line projecting at roughly at 45 degrees out from the centre of the blade.

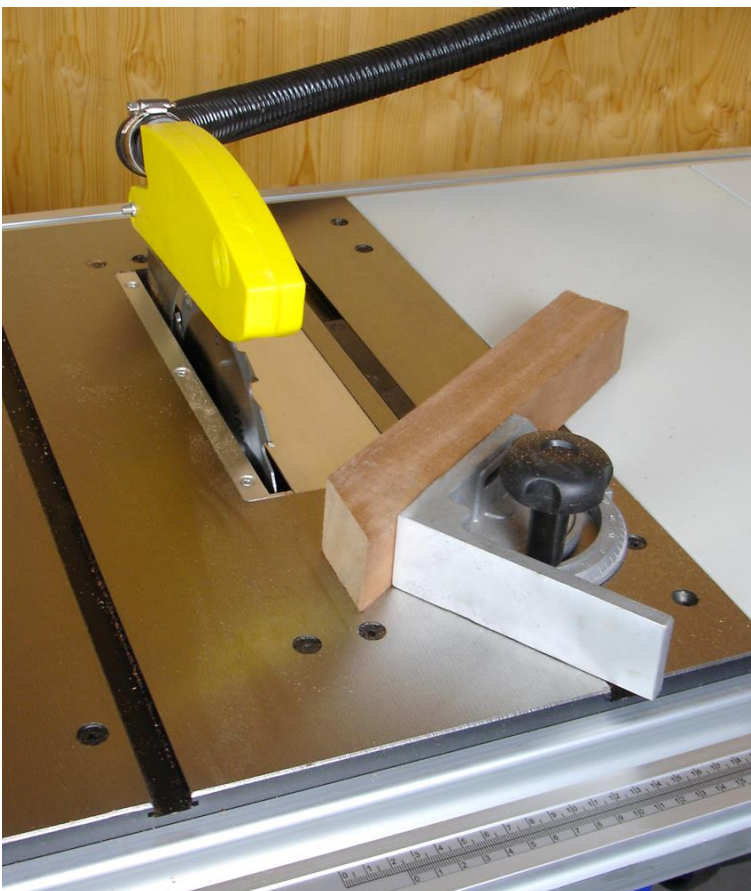

Cross Cutting

This saw has 2 options for making cross cuts: Using the sliding mitre fence or using the sliding carriage.

Cross Cutting With Sliding Mitre Fence

The sliding mitre fence is most suitable for cutting small pieces. It fits into either of the T-shaped channels in the table.

To set 90 degrees or any other angle, undo the locking knob and rotate the quadrant to the desired angle.

The work piece can be held against either face of the fence.

Cross Cutting With Sliding Carriage

The sliding carriage is more suitable when working with large flat panels.

To use the sliding carriage: Pull the table all the way forward.

Set the flip over stop to the desired width of cut when required.

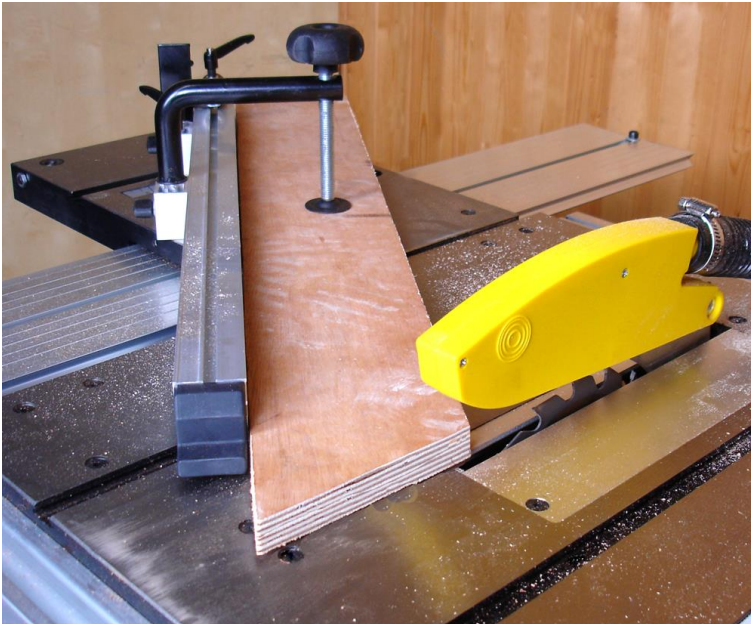

If an angle is to be cut, undo the 2 thumb screws and ratchet lever, swing the fence to the desired angle and lock them both off

If necessary, undo both thumb screws and adjust the fence so that the plastic tip is just clear of the blade.

Load the wood onto the carriage and screw down the work clamp to secure it.

Press the start button and push the wood through the saw blade.

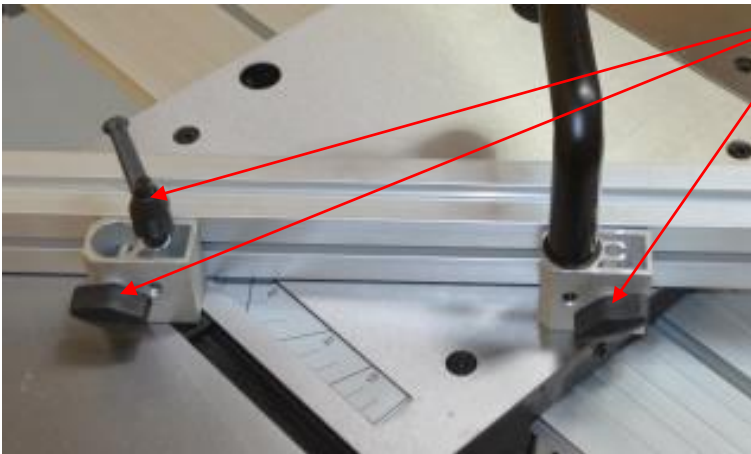

An alternative configuration is available for the sliding carriage. The fence can be assembled onto the back edge of the table in a mirror image of the standard configuration.

The work piece is loaded against the back edge of the fence and then fed onto the blade.

Using this configuration, the crosscut capacity can be increased and the sliding carriage guide rail can be moved backwards so that it does not obstruct the operator.

Blade Removal and Replacement

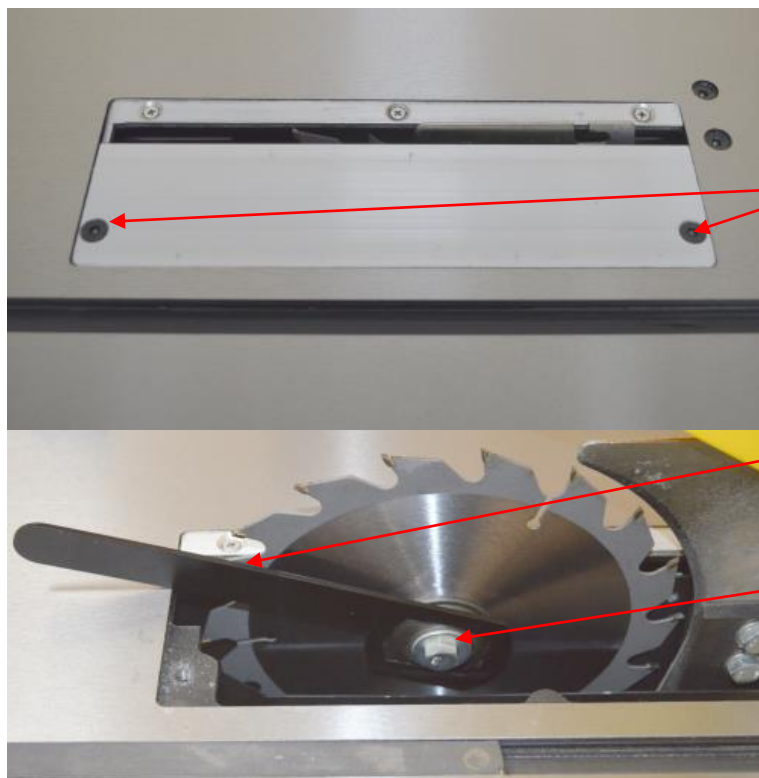

Unplug the saw from the power source.

Raise the blade to its maximum height and remove the saw guard from the riving knife.

Remove the right hand table insert, using a 4mm Hex key to remove the two screws.

Use the special spanner supplied, lock the spindle by fitting it over the black locking washer.

Then use a 13mm spanner to undo the blade locking bolt.

Remove the bolt, flat washer and locking washer. The blade can now be removed from the shaft.

Reverse this procedure to fit the new blade.

Adjusting Blade Alignment

1) Disconnect the saw from the power supply and remove the two blue side panels from the main body.

2) With a 4mm hex key loosen, but do not fully undo, the four Allen bolts located in the main cast iron table located just in front and behind the saw blade. There are four corresponding 10mm Nyloc nuts underneath the table.

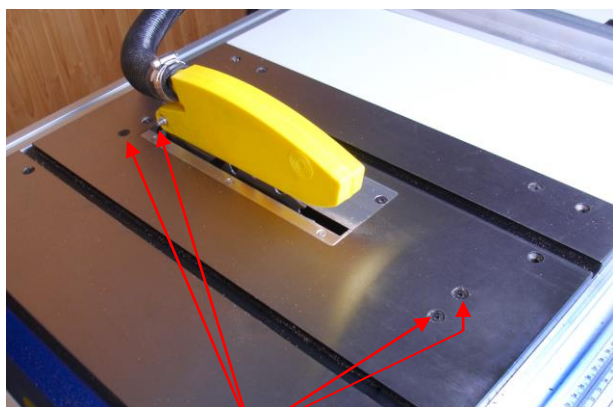

Allen Bolts

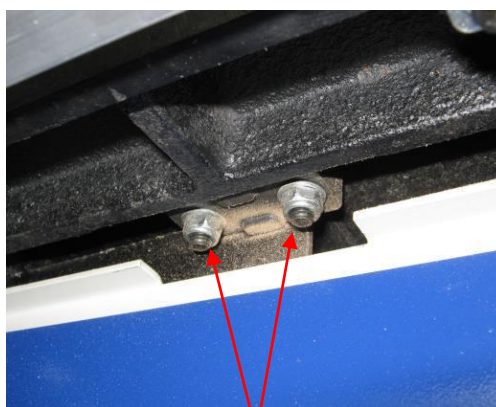

Nyloc Nuts

3) By holding the motor it is then possible to adjust the alignment of the sawblade in the table slot.

4) Measure the distance between the blade and the T slot in the table at both the front and rear of the blade, ensuring that both measurements are the same. Also, ensure that the blade will clear the table and insert when fully tilted.

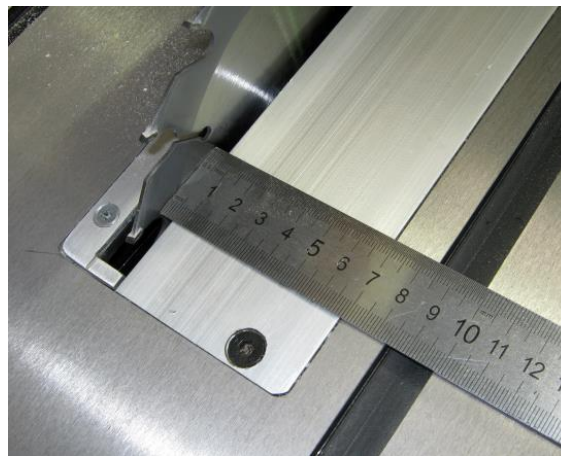
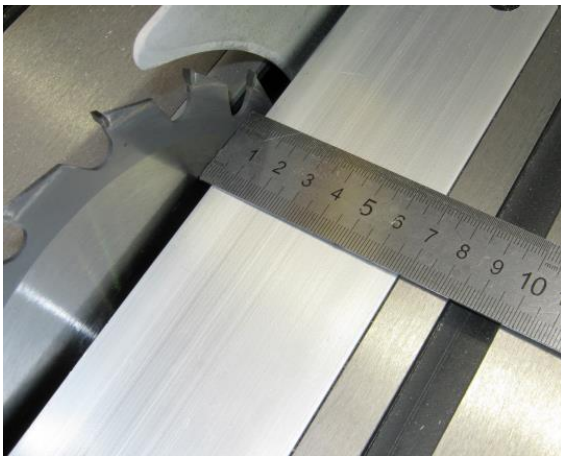

5) When you are satisfied the blade is aligned, re-tighten the Allen bolts and replace the side panels

Adjusting the Blade Tilt Limits

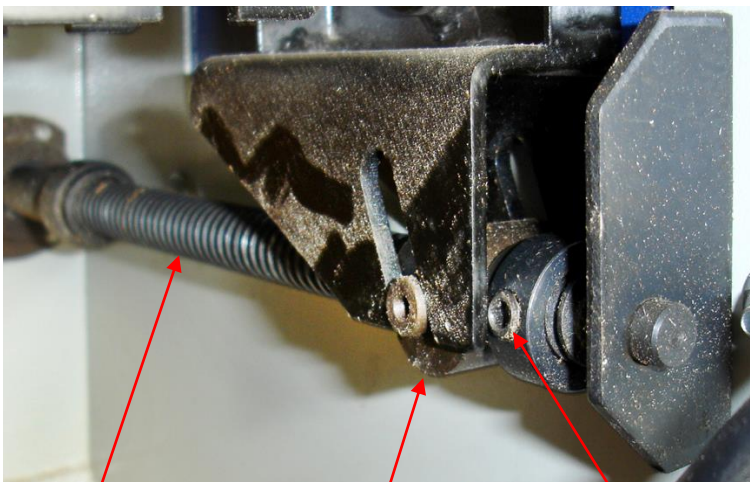

Threaded Shaft

Threaded Nut

90 Degree
Limiting Collar

Raise the blade to full height and remove the blade guard.

Remove both blue side panels from the base of the saw. The adjustment handwheel will need to be removed but should then be replaced and secured on the threaded shaft.

90 Degree Stop

With 4mm Allen Key, loosen the limiting collar fitted to the threaded shaft

Using a suitable square, accurately adjust the blade to 90 degrees.

Ensure that the square is positioned between teeth and is flat against the plate of the blade.

Hold the limiting collar firmly against the Threaded Nut and retighten the grub screw.

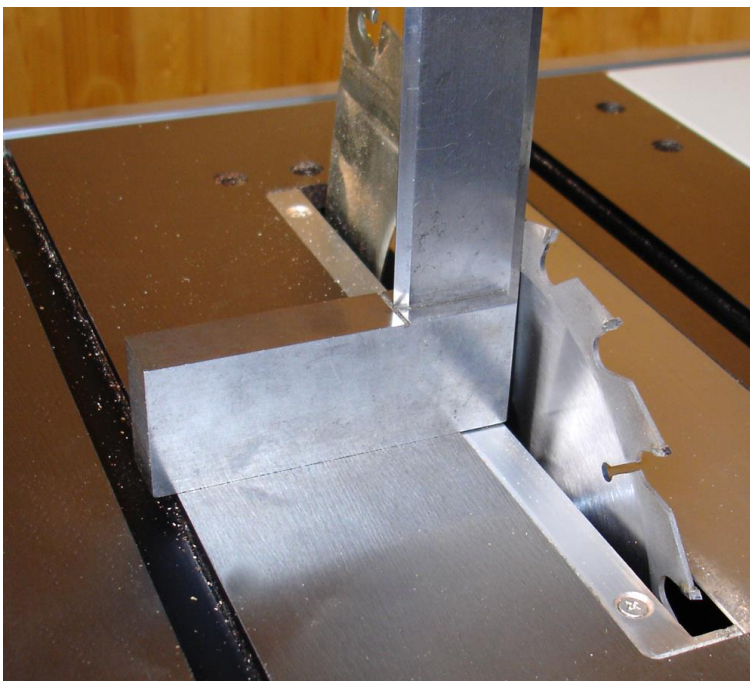

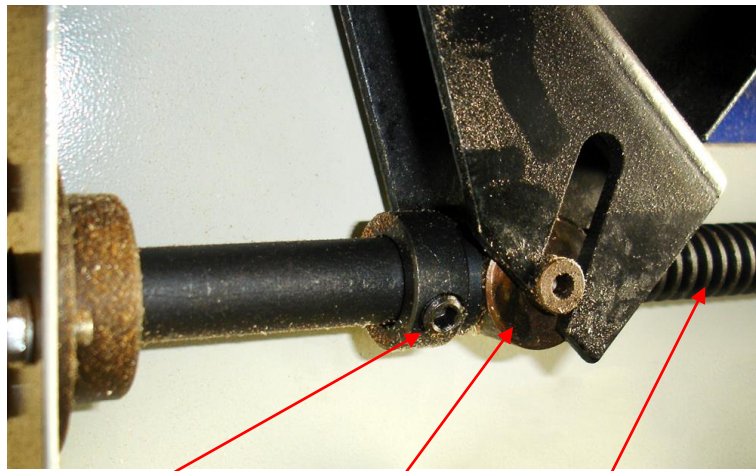

45 Degree
Limiting Collar

Threaded Nut

Threaded Shaft

45 Degree Stop

Using a 4mm Allen Key, loosen the 45 degree limiting collar situated at the opposite end of the threaded shaft.

Using a mitre square, adjust the blade accurately to 45 degrees.

Hold the limiting collar firmly against the Threaded Nut and retighten the grub screw.

Replace the blue covers and handwheel.



Troubleshooting Guide

Problem	Cause	Remedy
Machine does not start	Blown Fuse	Replace Fuse
	Loose switch terminal	Inspect back of switch
	Faulty switch	Replace switch
Only starts when Green button is held down	Faulty switch	Replace switch
Machine does not run but buzzing noise heard from motor	Failed capacitor	Replace the motor start capacitor.
Saw vibrates	Damaged teeth on saw blade	Check & replace the blade
	Floor stand is loose	Check all nuts and bolts for tightness
Cuts are slow, wood is blackened	Saw blade is blunt or damaged	Examine the blade. If any Tungsten tips are missing or broken the blade should be replaced. If the tips are blunt, the saw blade may to be professionally sharpened.
Saw stalls	Feed rate too high	Slow down
Wood binds on rear of saw blade	Rip fence is not parallel to blade	Bring the fence up to the blade and re-align the fence so it is parallel, by adjusting the 2 small set screws located on the guide rail brackets. (see assembly instructions for more details)
Lower saw guard fills with dust	No extraction fitted or extraction not working efficiently	It is essential to use a vacuum extractor or chip collector with this machine. If one is being used, check for blockages in the hose
Blade tilt or blade height difficult to adjust	Adjusting rod obstructed by dust build up	clean and lubricate the mechanism

Declaration of Conformity

Charnwood Declare that Circular Saw Bench, Model W619 & W619PSF

Conforms with the following EU Directives: Machinery Directive 2006/42/EC
Low Voltage Directive 2006/95/EC

Conforms with the following UK Regulations: Supply of Machinery (Safety) Regulations 2008
Electrical Equipment (Safety) Regulations 2016

And further conforms to the machinery example for which the EC type examination Certificate No. BM 50259867 and AN 50259868 have been issued by TUV Rheinland LGA Products GmbH, Tillystrasse 2, 90431 Nurnberg, Germany.

I hereby declare that equipment named above has been tested and found to comply with the relevant sections of the above referenced specifications. The machinery complies with all essential requirements of the directives and regulations.

Signed:  Dated: 01/05/2021 Location: Leicestershire

Richard Cook, Director



Please dispose of packaging for the product in a responsible manner. It is suitable for recycling. Help to protect the environment, take the packaging to the local amenity tip and place into the appropriate recycling bin.



Only for EU countries

Do not dispose of electric tools together with household waste material!
In observance of European Directive 2002/96/EC on waste electrical and electronic equipment (EEE) and its implementation in accordance with national law, electric tools that have reached the end of their life must be collected separately and returned to an environmentally compatible recycling facility.



Your local refuse amenity will have a separate collection area for EEE goods

CHARNWOOD W619 PARTS DIAGRAM A

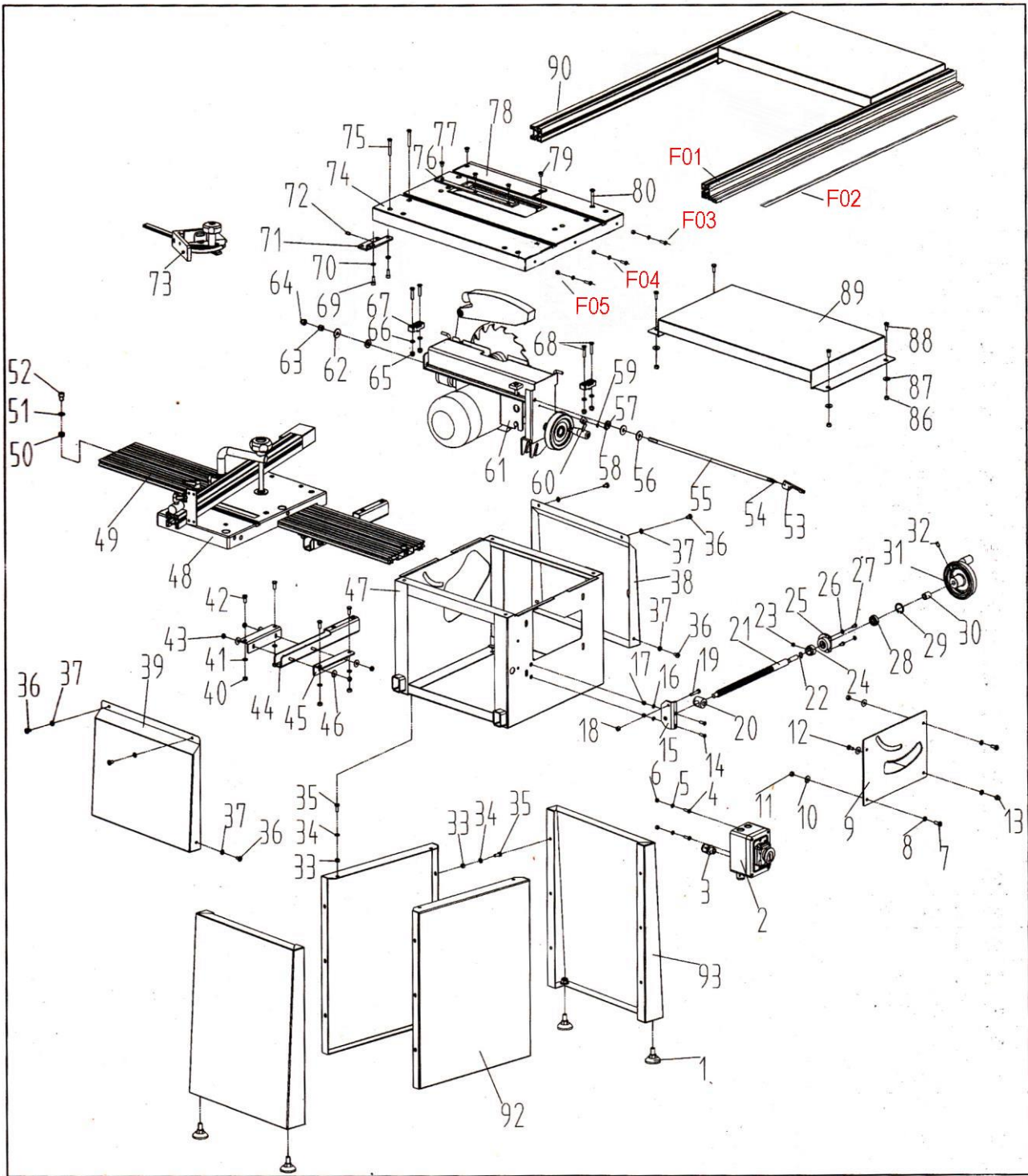

CHARNWOOD W619 PARTS LIST A

A01	Foot	A02	Switch
A03	Metric Bushing	A04	Screw M5 x 16mm
A05	Washer M5	A06	Hex Nut M5
A07	Screw M6 x 16mm	A08	Washer M6
A09	Saw Faceplate	A10	Large Washer
A11	Hex Nut M6	A12	Hex Bolt M6 x 12mm
A13	Hex Nut M6	A14	Screw M5 x 14mm
A15	Threaded Shaft Support	A16	Washer M5
A17	Locking Nut M5	A18	Hex nut M6
A19	Hex Bolt M6 x 30mm	A20	Threaded Nut
A21	Threaded Shaft	A22	C Ring 10mm
A23	Set Screw M8 x 6mm	A24	Limitative Bush
A25	Bearing Rack	A26	Washer M5
A27	Hex Bolt M5 x 10mm	A28	Bearing 6000
A29	C Ring 26mm	A30	Space Bush
A31	Hand Wheel	A32	Set Screw M6 x 12mm
A33	Hex Nut M6	A34	Washer M6
A35	Hex Bolt M6 x 16mm	A36	Screw M6 x 10mm
A37	Washer M6	A38	Protective Cover
A39	Protective Cover	A40	Hex Nut M6
A41	Washer M6	A42	Hex bolt M6 x 16mm
A43	Hex Nut M6	A44	Outstretched Arm
A45	Angle Iron	A46	Large Washer M6
A47	Box Assembly	A48	Sliding Table Assembly
A49	Guide Rail	A50	Hex Nut M8
A51	Washer M8	A52	Screw M8 x 10mm
A53	Locking Handle	A54	Pin 3 x 12mm
A55	Locking Shaft	A56	Large Washer M8
A57	Space Bush	A58	Screw M4 x 6mm
A59	Tooth Washer M4	A60	Pointer
A61	Saw Assembly	A62	Large Washer M8
A63	Locking Nut M8	A64	Hex Nut M8
A65	Locking Nut M6	A66	Washer M6
A67	Supporting Rear	A68	Screw M6 x 30mm
A69	Screw M6 x 16mm	A70	Washer M6
A71	Supporting Plate	A72	Screw M6 x 12mm
A73	Mitre Gauge	A74	Main Table
A75	Screw M6 x 45mm	A76	Aluminium Plate
A77	Screw M4 x 10mm	A78	Insert
A79	Screw M6 x 10mm	A80	Screw M6 x 45mm
A81	Washer M6	A82	Locking Nut M6
A86	Hex Nut M6	A87	Large Washer M6
A88	Hex Bolt M6 x 16mm	A89	Extending Table
A90	Table Support Extrusion - Rear	A92	Linking Plate
A93	Supporting Plate	F01	Fence Carrier Extrusion
F02	Scale – Self- Adhesive	F03	Hex Bolt M6 x 20mm
F04	Washer M6	F05	Nut M6

CHARNWOOD W619 PARTS DIAGRAM B

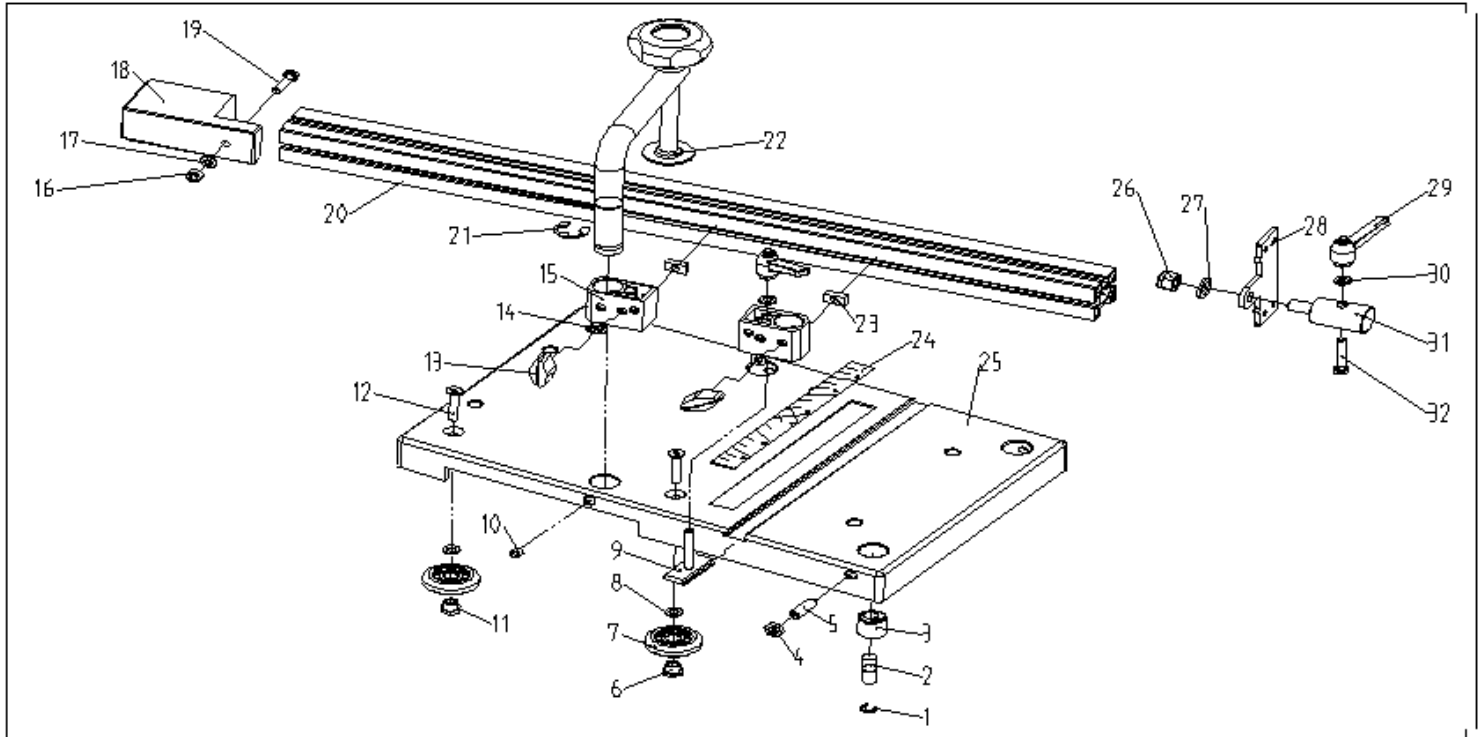

CHARNWOOD W619 PARTS LIST B

B01	C Shaped Ring	B02	Sliding Axle
B03	Eccentric Bush	B04	Hex Thin Nut M8
B05	Set Screw M8 x 25mm	B06	Eccentric Nut
B07	Trolley	B08	Washer M6
B09	T-Shape Bolt	B10	Set Screw M8 x 10mm
B11	Eccentric Nut	B12	CSK Screw M6 x 35mm
B13	Thumb Screw	B14	Washer M6
B15	Connecting Block	B16	Hex Nut M6
B17	Washer M6	B18	Plastic Tip
B19	Hex Bolt M6 x 25mm	B20	Angle Fence
B21	C Ring M12	B22	Press Handle
B23	Square Nut	B24	Angle Ruler
B25	Sliding Table	B26	Locking Nut M10
B27	Washer M10	B28	Length Stop Plate
B29	Ratchet Handle	B30	Washer M6
B31	Stop Block	B32	Hex Bolt M6 x 35mm

CHARNWOOD W619 PARTS DIAGRAM C

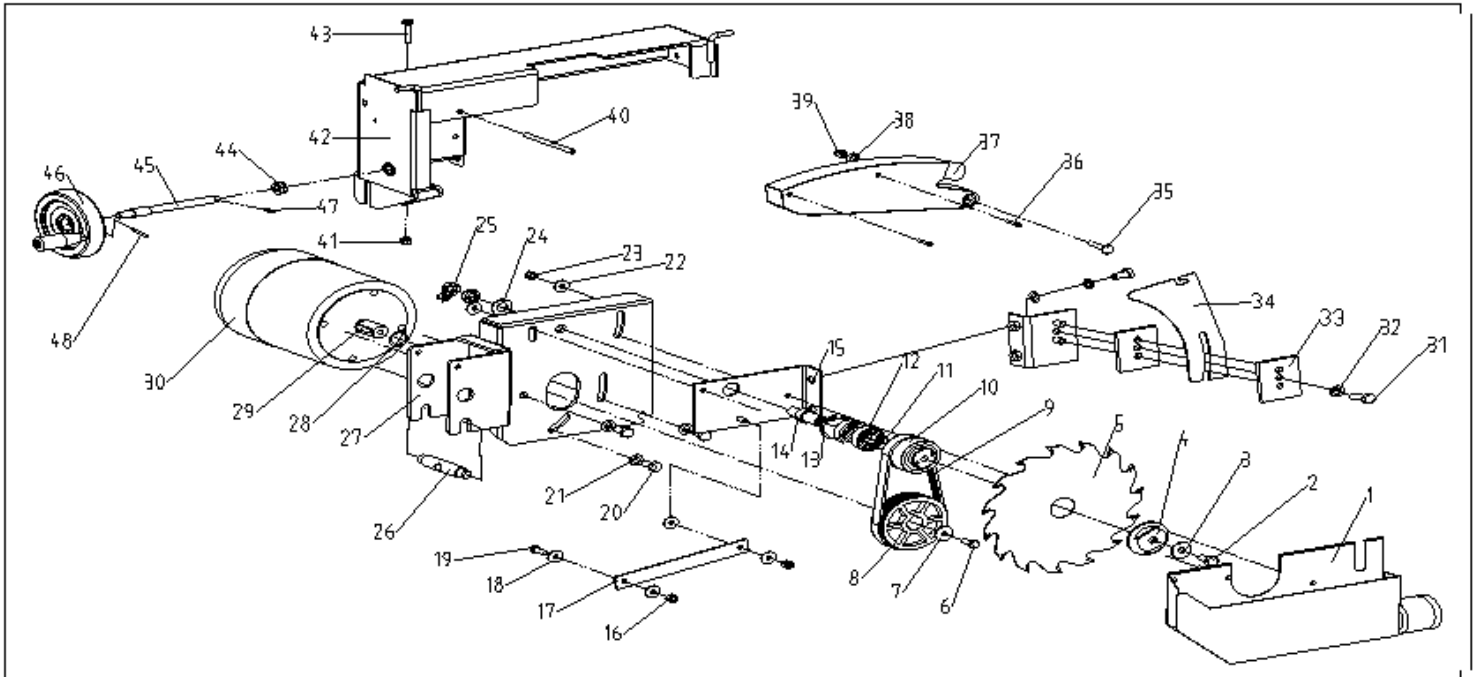

CHARNWOOD W619 PARTS LIST C

C01	Dust Collector	C02	Hex Bolt M8 x 16mm
C03	Large Washer M8	C04	Blade Locking Washer
C05	Saw Blade	C06	Hex Bolt M5 x 16mm
C07	Very Large Washer M6	C08	Motor Pulley
C09	Drive Belt	C10	Driven Pulley
C11	C Ring M15	C12	Bearing 6202
C13	C Ring M35	C14	Saw Axis
C15	Parallel Plate	C16	Locking Nut M6
C17	Connecting Plate	C18	Large Washer M6
C19	Hex Bolt M6 x 16mm	C20	Hex Bolt M8 x 16mm
C21	Washer M8	C22	Large Washer M6
C23	Locking Nut M6	C24	Washer M12
C25	Hex Thin nut M12	C26	Turning Pole
C27	Motor Rack	C28	C Ring M19
C29	Key 6 x 25mm	C30	Motor 240v
C31	Hex Bolt M8 x 25mm	C32	Washer M8
C33	Clamp Plate	C34	Riving Knife
C35	Bolt M6 x 30mm	C36	Bolt M6 x 30mm
C37	Saw Guard	C38	Washer M6
C39	Locking Nut M6	C40	Spring Pin M6 x 85mm
C41	Hex Nut M6	C42	Turning Support
C43	Hex Bolt M6 x 30mm	C44	Locking Nut
C45	Bolt Shaft	C46	Hand Wheel
C47	Spring Pin M3 x 16mm	C48	Spring Pin M3 x 25mm

CHARNWOOD W619 PARTS DIAGRAM E

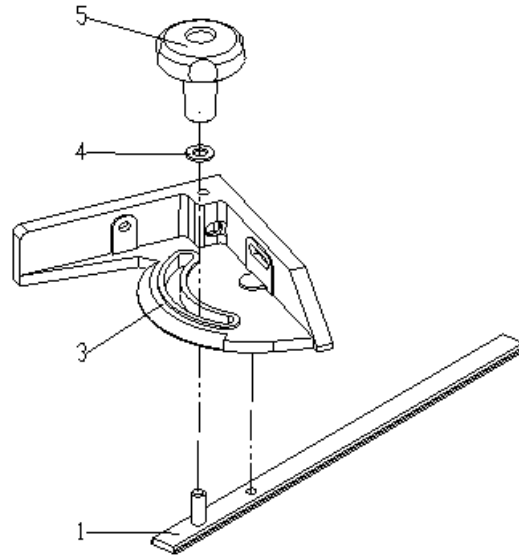

CHARNWOOD W619 PARTS LIST E

E01	T Shaped Runner		
E03	Mitre Gauge	E04	Washer M8
E05	Long Handle		

CHARNWOOD W619 PARTS DIAGRAM F

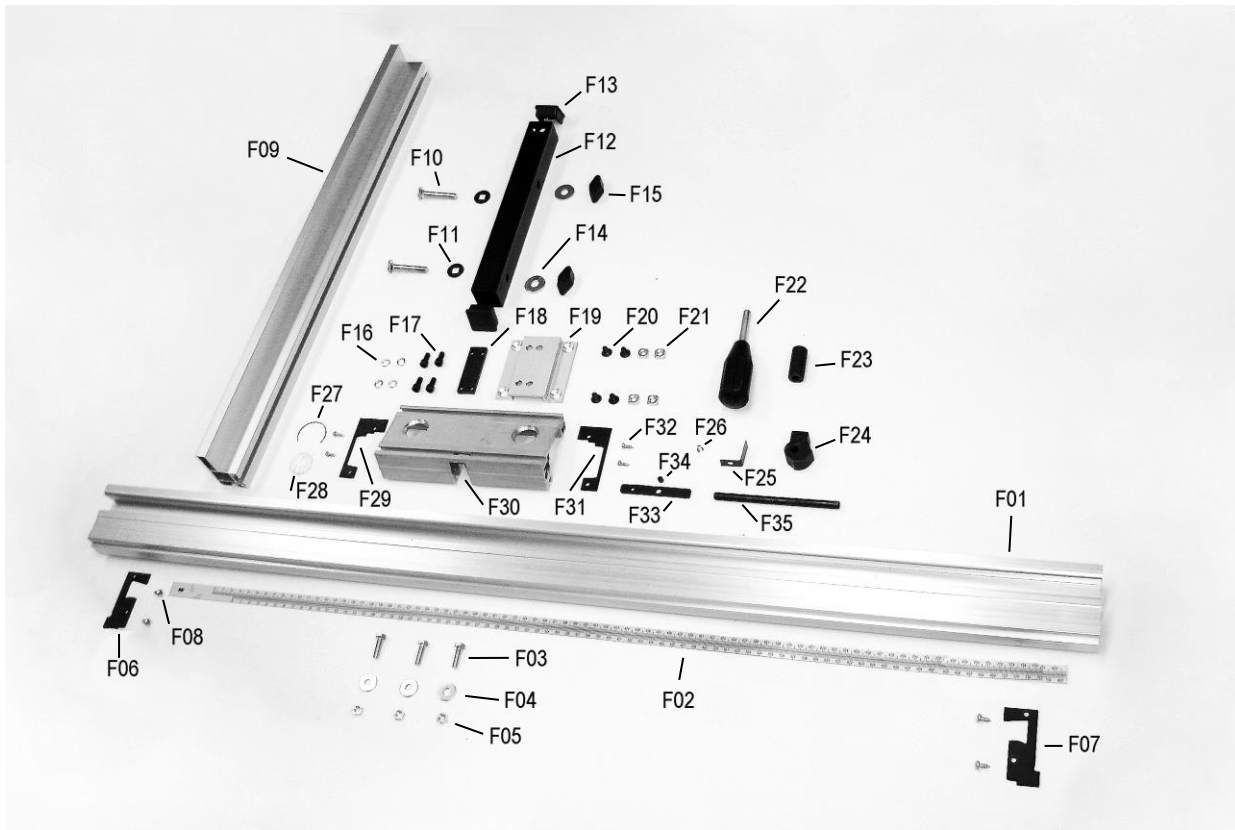

CHARNWOOD W619 PARTS LIST F

F01	Fence Carrier Extrusion	F02	Scale – Self-Adhesive
F03	Hex Bolt M6 x 20mm	F04	Washer M6
F05	Nut M6	F06	Carrier End Cap – Left
F07	Carrier End Cap – Right	F08	Self-Tapping Screw
F09	Pip Fence Extrusion	F10	Coach Bolt M8 x 45mm
F11	Plastic Spacer/Washer (Deleted)	F12	Fence Support Bracket
F13	Square End Cap	F14	Large Washer M8
F15	Fence Attachment Knob M8	F16	Spring Washer M6
F17	Hex Socket Bolt M6 x 12mm	F18	Threaded Plate
F19	Adjustable Bracket	F20	Countersunk Head Screw M6 x 10mm
F21	Square Slide Nut M6	F22	Fence Locking Handle
F23	Handle Spacer Tube	F24	Fence Locking Cam
F25	Spring Pressure Plate	F26	Self-Tapping Screw
F27	Lens Clip	F28	Cursor Lens
F29	Sliding Block End Cap - Left	F30	Sliding Block
F31	Sliding Block End Cap - Right	F32	Countersunk Screw M4 x 5mm
F33	Locking Bar	F34	Grub Screw M6
F35	Pivot Rod		



Woodworking machinery at its best!

Updated May 2021

Charnwood, Cedar Court, Walker Road,
Hilltop Industrial Estate, Bardon Hill, Leicestershire, LE67 1TU

Tel. 01530 516 926 Fax. 01530 516 929
email: sales@charnwood.net website: www.charnwood.net