

Charnwood

Woodworking machinery at its best!

FLOORSTANDING HOLLOW CHISEL MORTICER OPERATORS MANUAL

MODEL: W325



CE

Charnwood, Cedar Court, Walker Road,
Hilltop Industrial Estate, Bardon Hill, Leicestershire, LE67 1TU

Tel. 01530 516 926 Fax. 01530 516 929
email: sales@charnwood.net website: www.charnwood.net

GENERAL SAFETY RULES



WARNING: Do not attempt to operate the machine until you have thoroughly read and completely understood all instructions, rules, etc. contained in this manual. Failure to comply may result in accidents involving fire, electric shock, or serious personal injury. Keep this owner's manual and review frequently for continuous safe operation.

1. Know your machine. For your own safety, read the owner's manual carefully. Learn its application and limitations, as well as specific potential hazards pertinent to this machine.
2. Make sure all tools are properly earthed.
3. Keep guards in place and in working order. If a guard must be removed for maintenance or cleaning, make sure it is properly replaced before using the machine again.
4. Remove adjusting keys and spanners. Form a habit of checking to see that the keys and adjusting spanners are removed from the machine before switching it on.
5. Keep your work area clean. Cluttered areas and workbenches increase the chance of an accident.'
6. Do not use in dangerous environments. Do not use power tools in damp or wet locations, or expose them to rain. Keep work areas well illuminated.
7. Keep children away. All visitors should be kept a safe distance from the work area.
8. Make workshop childproof. Use padlocks, master switches and remove starter keys.
9. Do not force the machine. It will do the job better and be safer at the rate for which it is designed.
10. Use the right tools. Do not force the machine or attachments to do a job for which they are not designed. Contact the manufacturer or distributor if there is any question about the machine's suitability for a particular task.
11. Wear proper apparel. Avoid loose clothing, gloves, ties, rings, bracelets, and jewellery which could get caught in moving parts. Non-slip footwear is recommended. Wear protective hair covering to contain long hair.
12. Always use safety glasses. Normal spectacles only have impact resistant lenses. They are not safety glasses.
13. Do not over-reach. Keep proper footing and balance at all times.
14. Maintain the machine in good condition. Keep the machine clean for best and safest performance. Follow instructions for lubrication and changing accessories.
15. Disconnect the machine from its power source before servicing and when changing the chisel.
16. Never leave the machine running unattended. Turn the power off. Do not leave the machine until it comes to a complete stop.
17. Do not use any power tools while under the effects of drugs, alcohol or medication.

18. Always wear a face or dust mask if operation creates a lot of dust and/or chips. Always operate the tool in a well ventilated area and provide for proper dust removal. Use a suitable dust extractor.

ADDITIONAL RULES FOR Morticers

1. Support the chisel with a piece of wood when inserting or removing it from the tool. This will protect your fingers from the very sharp points!
2. When morticing long boards use one or more roller stand(s) to support the work.
3. Do not cut material that is badly warped or which has screws or nails in it.

Note: This morticer has been designed and built solely as a woodworking machine. Do not modify it in any way or use it for anything other than its designated purpose. Neither the manufactures nor the supplier are liable for any damage or injury caused by incorrect assembly, operation or electrical connection of this machine.

Important:



Risk of Injury!
Never reach into
the moving tool



Wear Eye
Protection



Wear Ear
Protection

Specification



From chisel bush to table	315mm (12")
Max. Timber height with 1/2" chisel fitted	205mm (8")
Max. timber clamping width	145mm (6")
Chisel capacity	1/4" to 1"
Vertical chisel stroke (1 stroke)	110mm (6")
Max. chisel travel	230mm (9")
Chisel shank diameter	3/4"
Table travel (left to right)	165 mm (6 1/2")
Table travel (front to back)	150mm (6")
Max distance from fence to c/l of mortice	150mm (6")
Length stop capacity	730mm (29")
Motor (induction)	750W (1hp), 240v
Motor speed	1400 rpm
Weight	120kg nett
Dimensions (W x D x H)	820 x 720 x 1800 mm
Rating	Trade
Warranty	1 year

Rating Description

Trade: Suitable for daily use by professional woodworkers.

Continuously rated, high power and a heavy duty construction. Typically used by several different operators in a small or medium sized business. Will be used up to the machines maximum limit with some long work periods. Expected maximum use of 1000 hours annually.

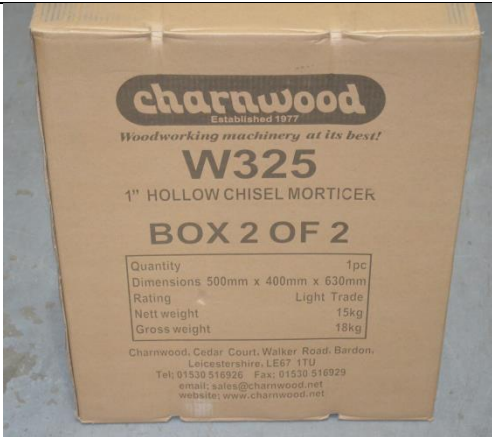
Unpacking and Assembly

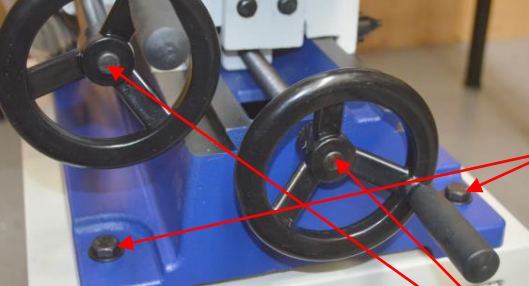
	<p>Cut the strapping and open the box 2 which contains the floor stand. Remove all parts from the packaging.</p> <p>Open the door and remove the bag containing the feet. Note that the keys to lock the door are secured to the inside of the lock.</p>
	<p>Fix the four feet to the base of floor stand, placing one washer on the threaded portion of each foot before passing it through the hole, adding the second washer and the spring washer, followed by the nut. Tighten securely.</p> <p>Place the floor stand on to its feet, and move it to where you want the machine to be located.</p>
<p style="text-align: center;"></p> <p style="text-align: center;">This is a very heavy machine. Do not attempt to lift it on your own!</p> <p style="text-align: center;">At least two people should should take part in any lifting or moving of this machine.</p>	<p>Next unpack the wooden crate. Cut the straps and lift the lid up off the base.</p> <p>The morticer is bolted down to the crate for safe transport. Unbolt the morticer from the base.</p>
	<p>Two people should lift the morticer on to the floor stand and line up the holes in the machine base with those drilled in the floor stand top.</p> <p>Fix the two parts together with the four 12mm bolts, nuts, washers and spring washes provided.</p> <p>Cut the cable tie and remove the handle and the work stop from the back of the column. Locate the bag of fittings.</p> <p>Fit the two round hand wheels to the two control shafts.</p>

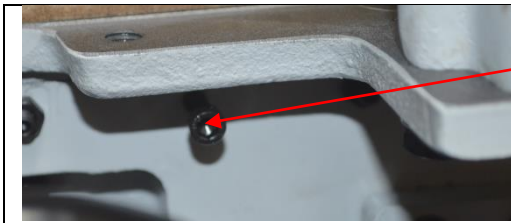

The table bed is locked in position for safe transport. Locate the locking socket head bolt on the front, which locks lateral table movement and loosen it.

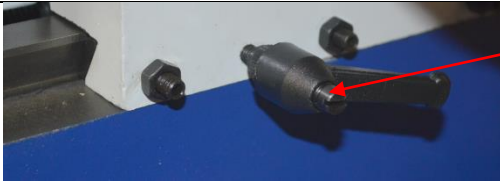

Locate the ratchet lever on the right hand side, which locks longitudinal movement and loosen it.

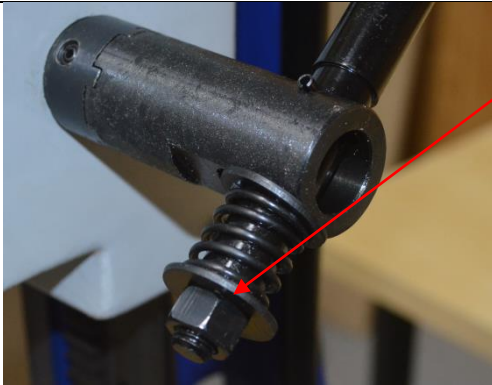

Take the handle and pass it through the hole in the shaft. Secure it with the spring, washer and nut provided.

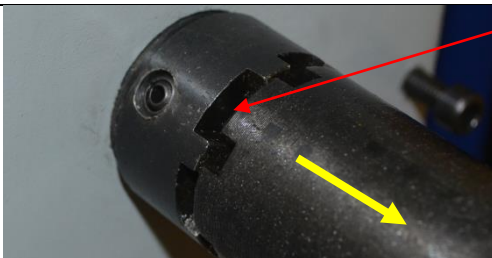

The down feed handle can be adjusted to always give a convenient starting position, regardless of the height of the timber being used.

To set the starting position, pull the handle out to the right, away from the machine, revealing the interlocking shaft. Rotate the handle to the best position and then allow it to move back and re-engage the drive shaft.

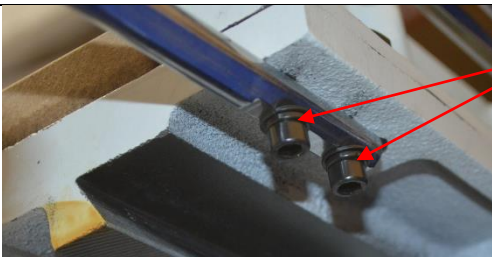

Bolt the end stop to the underside of the sliding bed, using the socket head bolts and washers provided.

The length stop can be fitted to the left or right hand side.

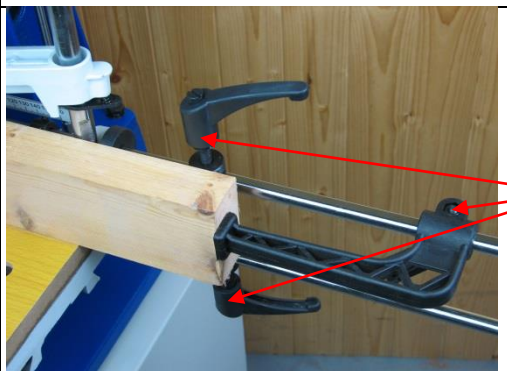

The length stop can be set to aid production runs where a series of identical components are to be produced.

By adjusting the 3 ratchet handles the position of the stop can be adjusted.

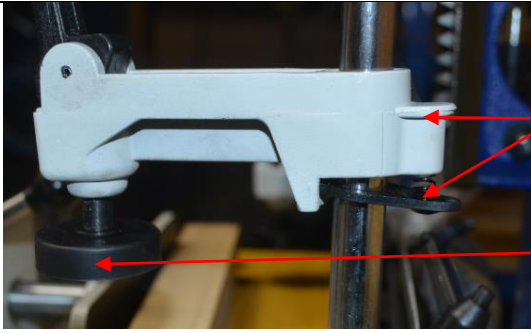

Fit the two hold down clamps over the vertical bars as shown.

Squeezing the locking plate and the thumb rest together will allow the clamp to slide up and down.

Use the cam lever to lower the round pad and clamp the timber.



To gain access to the drill chuck for chisel and auger fitting or changing,

remove the locking screw

depress this catch and hinge the door downwards.

There is a similar door at the other side.

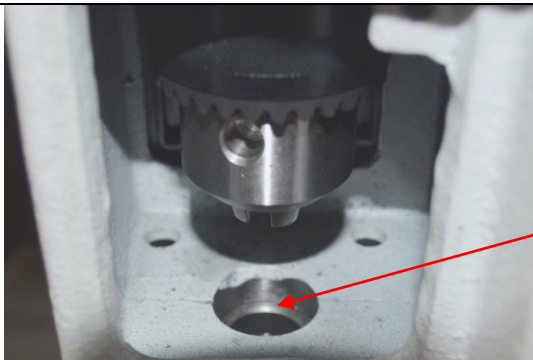

The drill chuck is now accessible.

Please note that the chuck key is spring loaded and that it needs to be pressed in firmly to engage.

The top of the bushing is visible here. The bush supplied with the machine is 3/4" diameter and only chisels of that shank size should be used.

An optional 13/16" diameter bush is available.

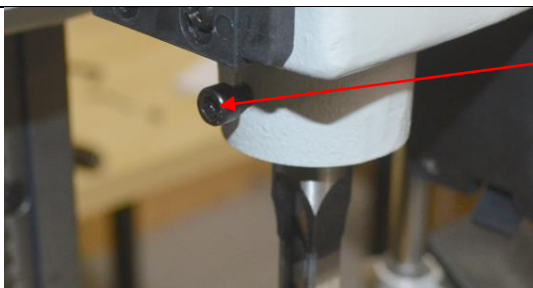

The chisel bushing is held in position by this set screw. It passes through the bushing and, when tightened, locks the chisel in place.

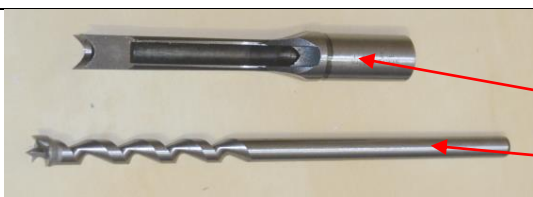

The tooling comes in 2 parts:

Hollow Chisel

Auger Bit

The auger must be inserted into the chisel prior to being inserted into the chuck. Take care when handling, the tips of the chisel are very sharp.

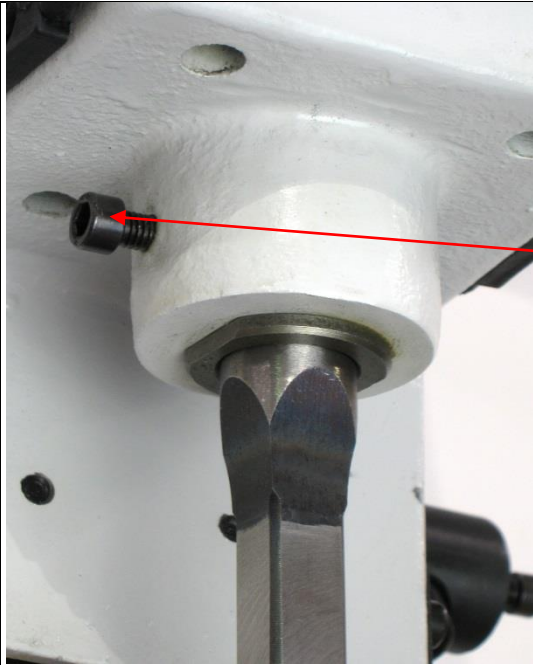

Setting the Chisel & Auger

Wearing a sturdy glove or using a cloth to support the sharp end of the chisel & auger. Insert the chisel & auger up into the bushing and into the drill chuck.

Lock the chisel into place using the socket head bolt.

Next set the height of the auger and lock it in place with the chuck key.

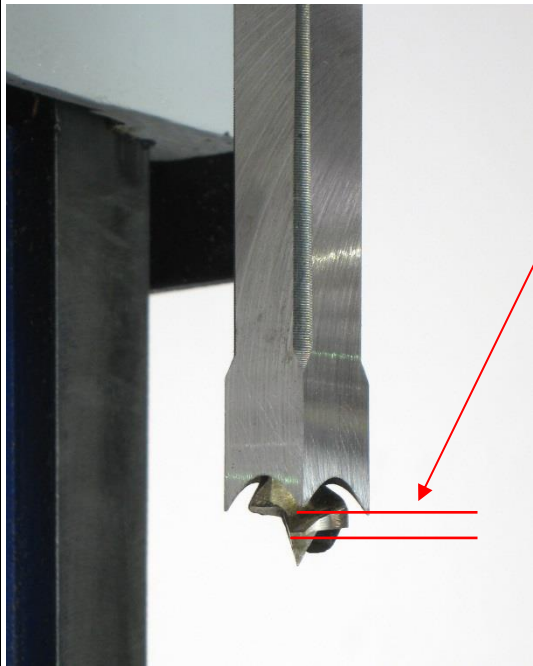

The Auger has a spur in the centre and a flat cutting lip. This cutting lip must be set below the four points of the chisel.

The recommended setting between the chisel tips and the flat cutting lip is between 2mm to 5mm. Set the height of the auger and then lock it into the chuck using the chuck key.

Try adjusting the height setting of the auger if cutting the mortice proves difficult in hardwood or if the waste wood is not being carried up the flute of the auger for ejection.

The chisel has an open side. This is to allow the waste wood to be ejected from the side. The chisel should be aligned with the slot facing to the right. To adjust it, leaving the auger in place, loosen the chisel locking bolt and rotate the chisel.

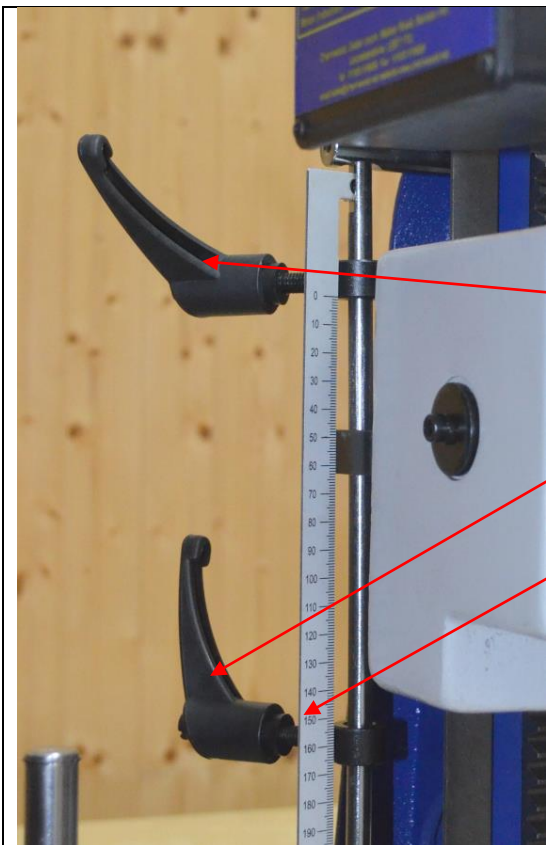

On the left hand side of the morticer there is a scale and two ratchet handles on a sliding collar.

The upper handle is used to set the starting position of the head. Lowering the starting position of the head is useful when working with small timbers and speeds up the process.

The depth of the mortice can be set by moving the lower handle to the desired position.

A scale is provided to aid repeatability.

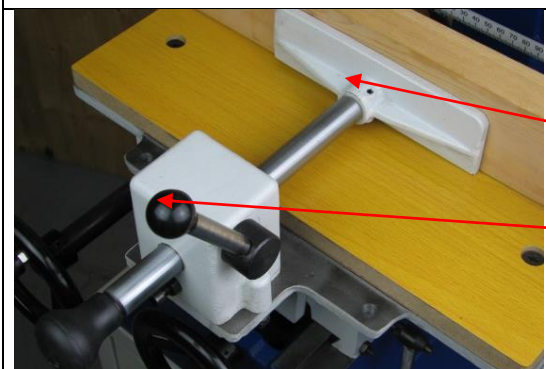

To set the front clamp, start with the locking lever in the vertical position.

Slide the front clamp forward firmly against the work piece.

Rotate the locking lever into the horizontal position to lock the clamp.



To start and stop the morticer, it is fitted with an NVR switch, located on the left hand side of the motor housing.

Using the Morticer

Set the gap between auger cutting lip and chisel tips.

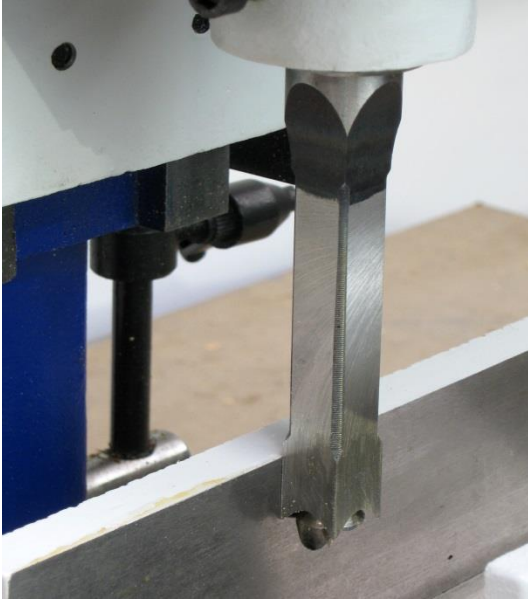

Next set the chisel square to the back fence. The easiest way to do this is to lower the chisel and wind the sliding bed forwards until it just touches the back of the chisel. If necessary, rotate the chisel until it is square.

When setting the depth of a mortice, allow for the fact that the drill bit precedes the chisel, which actually cuts the square shape. The tip of the auger cuts indentations in the bottom of the mortice. These are useful. When the joint is glued up and assembled some of the glue is scraped from the sides and the irregular bottom surface gives that displaced glue somewhere to go.

You may find it helpful to mark the outline of the mortice, including the depth, on the outside of the work piece. Set the depth limiter so that the points of the chisel reach the marked line. The tip will go below this line.



Clamp the workpiece firmly to the bed. Use the front clamp to hold the timber up against the back fence, use the two vertical clamps to hold the timber down against the table. If not clamped securely the workpiece may lift off the bed when the morticer head is raised.

Assuming that you have set the open side of the chisel facing to the right, make the first cut at the right hand end of the mortice. Using the left hand wheel, move the sliding bed so that the right hand end of the mortice is lined up with the right hand side of the chisel.

Using the central hand wheel, line the front of the mortice up with the front of the chisel.

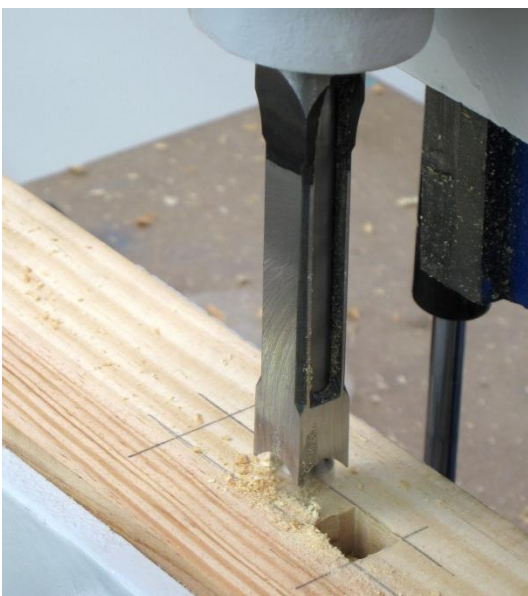

Start the motor, wait for it to come up to speed, pull down on the down feed handle of the morticer. You should aim for a cut rate that does not cause the motor labour but still produces a progressive entry of the chisel into the wood.

If a deep mortice is being cut, it should be completed in two passes.

It is important that the chips produced by the cut are able to eject from the chisel.

Make the first cut to a depth of about 20mm then raise the chisel. Now move the table to the right and start the next cut.



Position the table so that the chisel cuts almost its complete width. The chippings will be ejected into the space created by the previous cut. Continue moving along the mortice, cutting a series of holes, until the complete length of the mortice has been cut.

If a mortice deeper than 20mm is required:

Go back to the position of the first cut and repeat the procedure going deeper with the chisel.



If the width of the mortice is bigger than the chisel being used, use the central hand wheel to move the table backwards and again repeat the procedure to cut another series of holes in front of the first set.

If required, clean out the mortice with a suitable sized flat chisel or screwdriver.

Maintenance

Little maintenance is required. Keep the machine clean. Lubricate the slides and other moving parts occasionally.

It is possible to sharpen the flat lip and the spur of the auger with a small diamond file or slip stone.

The chisel can only be sharpened with a specialist tool but these are very expensive and it is generally better to consider the chisel and auger set as disposable.

Troubleshooting

Problem	Cause	Remedy
Machine does not start	Blown Fuse	Replace Fuse
	Loose switch terminal	Inspect back of switch
	Faulty switch	Replace switch

Problem	Cause	Remedy
Chisel will not fit into the bush	Incorrect shank size on Chisel	This morticer uses 3/4" diameter shank. An optional bush is available to use chisels with a 13/16" diameter shank
Only starts when Green button is held down	Faulty switch	Replace switch
Machine does not run but buzzing noise heard from motor	Failed capacitor	Replace the motor start capacitor.
Cuts are slow, wood is blackened	Chisel & auger is blunt or damaged	Examine the tooling. If damaged or worn it should be replaced
Chisel smokes or starting to blue	Check clearance from auger to chisel is adequate	Adjust height of auger
	Spiral flute of the auger is blocked up	Clear any blockage before continuing
	Speed of cut is too slow	Move chisel through timber faster

Declaration of Conformity for CE Marking

Charnwood Declare that Hollow Chisel Morticer, Model W325

Conforms with the following Directives: Machinery Directive 2006/42/EC
Low Voltage Directive 2006/95/EC

And further conforms to the machinery example for which the EC type examination Certificate No. AM 50171898 and AN 50171896 have been issued by TUV Rheinland LGA Products GmbH, Tillystrasse 2, 90431, Nurnberg.

I hereby declare that equipment named above has been tested and found to comply with the relevant sections of the above referenced specifications. The machinery complies with all essential requirements of the directive.

Signed:  Dated: 20/02/2010 Location: Leicestershire

Richard Cook, Director



Please dispose of packaging for the product in a responsible manner. It is suitable for recycling. Help to protect the environment, take the packaging to the local amenity tip and place into the appropriate recycling bin.



Only for EU countries

Do not dispose of electric tools together with household waste material!
In observance of European Directive 2002/96/EC on waste electrical and electronic equipment (EEE) and its implementation in accordance with national law, electric tools that have reached the end of their life must be collected separately and returned to an environmentally compatible recycling facility.



Your local refuse amenity will have a separate collection area for EEE goods

Charnwood W325 Morticer Parts Drawing A

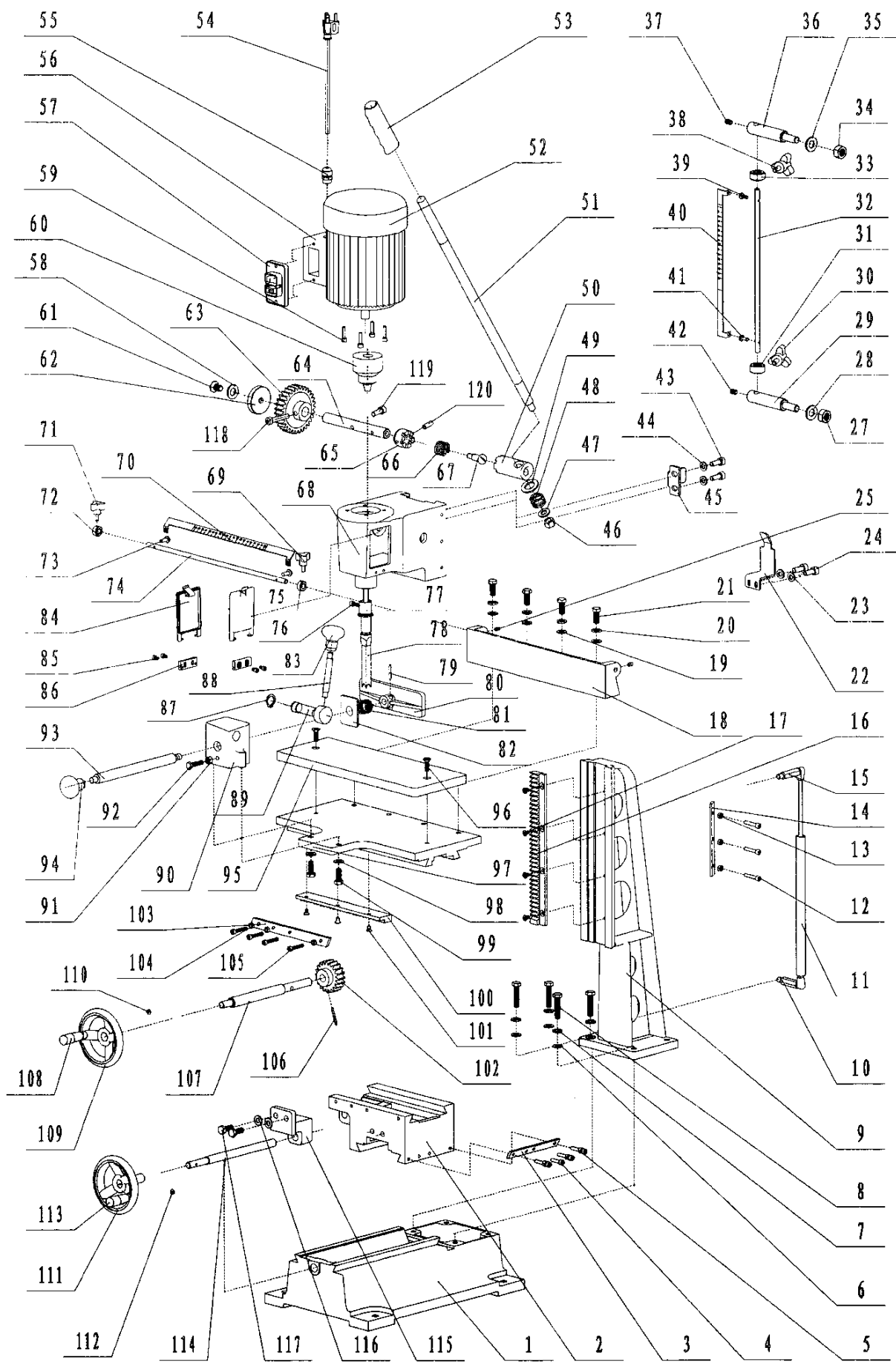

Charnwood W325 Morticer Parts List A

A001	Base	A061	Screw, M6 x 10mm
A002	Middle Base	A062	Cover
A003	Drift	A063	Gear
A004	Set Screw, M6 x 35	A064	Shaft
A005	Hex Nut M6	A065	Connecting Bend
A006	Washer M10	A066	Spring
A007	Wave Washer M10	A067	Screw
A008	Cap Screw M10 x 40	A068	Headstock
A009	Column	A069	Screw
A010	Screw	A070	Ruler Mark
A011	Gas Spring	A071	Screw
A012	Set Screw M6 x 35	A072	Setting collar
A013	Hex Nut M6	A073	Screw M4 x 12
A014	Drift	A074	Setting Rod
A015	Screw	A075	Setting Collar
A016	Rack	A076	Screw M6 x 25
A017	Screw M6 x 10	A077	Bushing
A018	Fence	A078	Morticing Chisel & Bit
A019	Washer M10	A079	Pin
A020	Wave Washer M10	A080	Clamp Plate
A021	Cap Screw M10 x 25	A081	Spring
A022	Localizer	A082	Spring Cover
A023	Washer M6	A083	Handle
A024	Screw M6 x 15	A084	Cover
A025	Screw M6 x 10	A085	Screw M5 x 10
A026		A086	Cover Base
A027	Hex Nut M10	A087	C Clip / Circlip 20mm
A028	Washer M10	A088	Handle
A029	Screw	A089	Shaft
A030	Screw	A090	Clamping Block
A031	Setting Collar	A091	Nut M10
A032	Setting Rod	A092	Screw M8 x 25
A033	Setting Collar	A093	Locking Shaft
A034	Hex Nut M10	A094	Handle
A035	Washer M10	A095	Wood Table
A036	Screw	A096	Screw M8 x 25
A037	Screw M6 x 15	A097	Table
A038	Screw	A098	Washer M10
A039	Screw M4 x 12	A099	Screw M10 x 25
A040	Depth Ruler	A100	Rack
A041	Screw M4 x 12	A101	Screw M6 x 10
A042	Screw M6 x 15	A102	Gear
A043	Screw M6 x 15	A103	Drift
A044	Washer M6	A104	Nut M6
A045	Localizer	A105	Screw M6 x 15
A046	Hex Nut M12	A106	Pin
A047	Washer M12	A107	Gear Shaft
A048	Spring	A108	Collar
A049	Washer M14	A109	Hand wheel

A050	Connecting Bend	A110	Screw M8 x 10
A051	Handle	A111	Hand wheel
A052	Motor	A112	Screw M8 x 10
A053	Handle Grip	A113	Collar
A054	Power Cord	A114	Lead Screw
A055	Strain Relief Bushing	A115	Lead Nut
A056	Switch Box	A116	Washer M10
A057	Switch CK1/KJD6	A117	Screw M10 x 25
A058	Washer	A118	Screw M8 x 45
A059	Screw M6 x 25	A119	Screw M8 x 20
A060	Chuck 16mm	A120	Pin
		#CAP	Capacitor 16uf 450V

Charnwood W325 Morticer Parts Drawing B

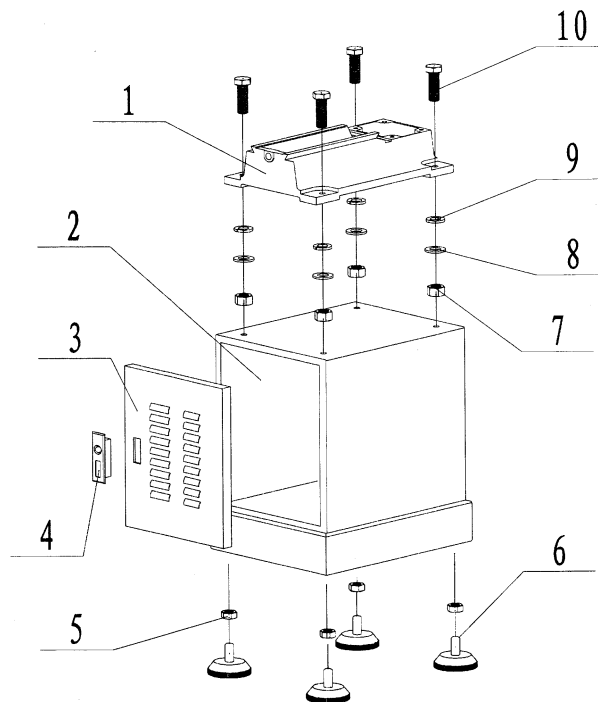

Charnwood W325 Morticer Parts List B

B01	Base	B06	Stand Base
B02	Stand	B07	Hex Nut M10
B03	Door	B08	Washer M10
B04	Door Latch	B09	Wave Washer M10
B05	Hex Nut M10	B10	Cap Screw M12 x 40

Charnwood W325 Morticer Parts Drawing C

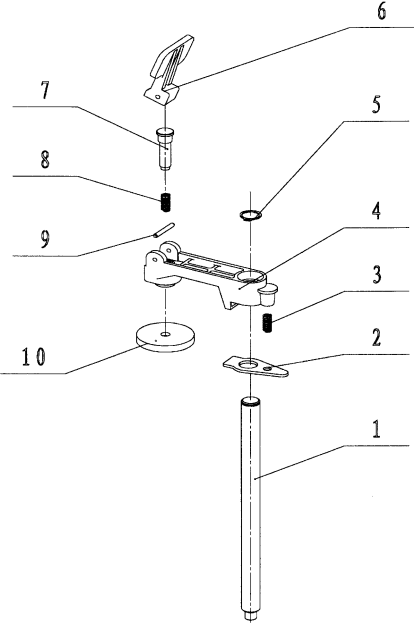

Charnwood W325 Morticer Parts List C

C01	Shaft	C06	Locking Handle
C02	Setting Piece	C07	Locking Screw
C03	Spring	C08	Spring
C04	Clamping Body	C09	Pin
C05	C-Clip/ Circlip	C10	Stop Disc

Charnwood W325 Morticer Parts Drawing D

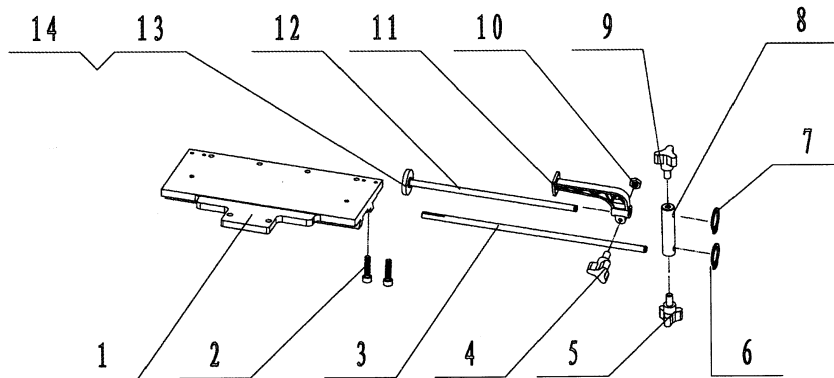

Charnwood W325 Morticer Parts List D

D01	Table	D08	Length Setting Block
D02	Cap Screw M6 x 25	D09	Handle Screw (Large)
D03	Rear Length Setting Rod	D10	Nut M6
D04	Handle Screw	D11	Stop Disc
D05	Handle Screw (Large)	D12	Front Length Setting Rod
D06	C-Clip/ Circlip	D13	Washer
D07	C-Clip/ Circlip	D14	Stop Disc



Woodworking machinery at its best!

**Charnwood, Cedar Court, Walker Road, Hilltop Industrial Estate,
Bardon, Leicestershire, LE67 1TU**

Tel. 01530 516 926 Fax. 01530 516 929
email: sales@charnwood.net website: www.charnwood.net