



Woodworking machinery at its best!

SPINDLE MOULDER OPERATING INSTRUCTIONS

MODEL: W040



**Charnwood, Cedar Court, Walker Road,
Hilltop Industrial Estate, Bardon Hill, Leicestershire, LE67 1TU**

**Tel. 01530 516 926 Fax. 01530 516 929
email: sales@charnwood.net website: www.charnwood.net**

Forward

These instructions are important, the information contained herein is essential for the correct build and operation of the machine and the safety of its operator.

The machine is equipped with various safety devices to protect itself and the operator. However, these devices cannot cover all eventualities and a thorough understanding of spindle moulding techniques, good workshop practice plus the controls and operation of this machine are essential for your safety.

Do not operate the machine until you have read and understood all the instructions in this manual and are familiar with both the machine and spindle moulding techniques.

Use of the Machine

Purpose

This machine is designed for moulding along and across the grain of prepared timber, using cutters and limiters, correctly mounted in a standard Euroblock.

It is designed for use by one operator.

Operator Qualifications/Training

Operators of this machine should have a suitable qualification in the use of woodworking machinery, including spindle moulders or should have been trained by someone holding such qualifications.

GENERAL SAFETY RULES



WARNING: Do not attempt to operate the machine until you have read thoroughly and understood completely all instructions, rules, etc. contained in this manual. Failure to comply may result in accidents involving fire, electric shock, or serious personal injury. Keep this owner's manual and review it frequently for continuous safe operation.

1. Know your machine. For your own safety, read the owner's manual carefully. Learn its application and limitations, as well as specific potential hazards pertinent to this machine.
2. Make sure all tools are properly earthed.
3. Keep guards in place and in working order. If a guard must be removed for maintenance or cleaning, make sure it is properly replaced before using the machine again.
4. Remove adjusting keys and spanners. Form a habit of checking to see that the keys and adjusting spanners are removed from the machine before switched it on.
5. Keep your work area clean. Cluttered areas and workbenches increase the chance of an accident.'
6. Do not use in dangerous environments. Do not use power tools in damp or wet locations, or expose them to rain. Keep work areas well illuminated.
7. Keep children away. All visitors should be kept a safe distance from the work area.
8. Make workshop childproof. Use padlocks, master switches and remove starter keys.
9. Do not force the machine. It will do the job better and be safer, at the rate for which it is designed.
10. Use the right tools. Do not force the machine or attachments to do a job for which they are not designed. Contact the manufacturer or distributor if there is any question about the machine's suitability for a particular job.
11. Wear proper apparel. Avoid loose clothing, gloves, ties, rings, bracelets, and jewellery which could get caught in moving parts. Non-slip footwear is recommended. Wear protective hair covering to contain long hair.
12. Always use safety glasses. Normal spectacles only have impact resistant lenses. They are not safety glasses.
13. Do not over-reach. Keep proper footing and balance at all times.
14. Maintain machine in good condition. Keep machine clean for best and safest performance. Follow instructions for lubrication and changing accessories.

15. Disconnect the machine from its power source before servicing and when changing accessories.
16. To avoid accidental starting, make sure the switch is in the OFF position before plugging in the mains cable.
17. Never leave the machine running unattended. Turn the power off. Do not leave the machine until it comes to a complete stop.
18. Do not use any power tools while under the effects of drugs, alcohol or medication.
19. Always wear a face or dust mask if operation creates a lot of dust and/or chips. Always operate the tool in a well ventilated area and provide for proper dust removal. Use a suitable dust extractor.

EXTRA RULES FOR SPINDLE MOULDERS

1. A spindle moulder should never be used by an untrained operator. Proper training is essential for the operator's safety.
2. The machine must be properly maintained and the correct fitting of all guards checked.
3. Guards should be of such a design and fitted in such a way that they keep fingers out of an area of 50 mm (2 inches) beyond the sweep of any cutter that might be used.
4. Always ensure that you use safe working procedures and that you understand what you are doing.
5. Wear appropriate clothing. Long loose sleeves, long hair or anything else that could get caught in the machine should be tied back or otherwise secured.
6. Never use this spindle moulder for curved work.
7. **NEVER** use a cutter block without limiters.
8. Feed the workpiece to the cutter block or router bit against the direction of rotation.
9. Never draw the workpiece back during cutting. Wait until the block stops rotating before pulling the workpiece back.



Risk of injury!
Never reach into
moving tooling.



Wear Eye
Protection



Wear Ear
Protection

Specification

Main table surface	600 x 400mm
Sliding beam surface	1,000 x 200mm
Sliding beam stroke	620mm
Table height	870mm
Dimensions (WxDxH)	1000mm x 1070mm x 1280mm
Weight Net/Gross	82/85kg
Spindle diameter	30mm
Rotation speeds	4(1400/4000/6000/9000) rpm
Spindle length available for tooling	105mm
Spindle rise and fall	110mm
Table aperture (with inserts)	160mm (110/75mm)
Table aperture depth	50mm
Motor (induction)	240V, 1500W single phase
Fence size	125 x 700 mm
Extractor outlet	100mm
Rating	Light trade
Warranty	1 year

Rating

Light Trade: Suitable for professional woodworkers where the machine will not be in daily use.

Mid-range machines with a heavier build and more power. Typically used by 2 or 3 people within a small business and also for the dedicated hobbyist with a larger budget. It is expected to be used up to the machines maximum limit with occasional long work periods. Suitable for income generation.

Expected maximum use of 300 hours annually.

Unpacking

All parts are packed in one carton and one crate.



Cut the strapping and lift the lid of the crate from the base. The machine is fixed to the base with two bolts; Remove the bolts from the underside and lift the machine off the base.

Remove the protective paper from the cast iron table top and wipe clean the grease, using a rag and some WD40 or similar de-greaser.



Open the carton and carefully slide out the wooden tray.

In this tray, you will find the sliding beam.



In the cutter block recess you will find the spindle arbor and the routing collet, which will take 1/2" shank diameter router cutters.



Open the blue door on the side of the machine.



Reach in and remove the carton and other accessory items you will find packed inside.



Unpack the components and familiarise yourself with them.



Locate the four feet, noting that they have spanner flats just below the threaded portion. Tilt the machine, prop it with a timber block and screw in two feet. Remove the block, repeat the procedure on the other side. Use a spanner to adjust the feet so that the machine is level.



Fit the hand wheel to the rise and fall control shaft and tighten the grub screw.

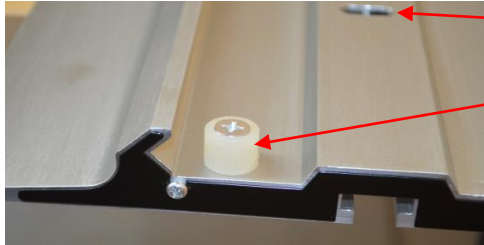

Slot (See below)

Remove one of the nylon stops from the underside of the sliding beam, using a no.3 Philips head screwdriver.

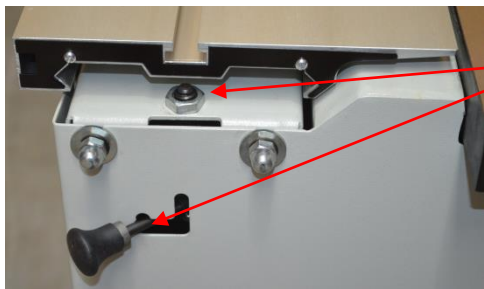

Lower the retractable sliding beam lock, by moving the lever down and to the left, slide the beam onto the guide rollers. Refit the nylon stop.

Note: The thin edge of the beam is closest to the main table.



When the retractable lock is in its raised position, it will engage with the slot in the underside of sliding carriage. This will lock the beam in position and stop it from sliding when not required.



Here you can see the tapered end of the spindle.



Locate the spindle lock bar on the right hand side of the machine. Rotate the tapered spindle slowly whilst pressing the locking bar inwards. When the lock engages the bar will slide in around 10mm and the spindle will be locked.

Pull the bar out to unlock the spindle.



With the tapered spindle locked, fit the upper spindle.

Use a flat screwdriver to unscrew the locking ring in the centre of the upper spindle.

Place the upper spindle over the taper and tighten the retaining screw by passing a 6mm Allen key into the centre of the spindle.

Next use the flat screwdriver to tighten the locking ring down onto the head of the retaining screw.

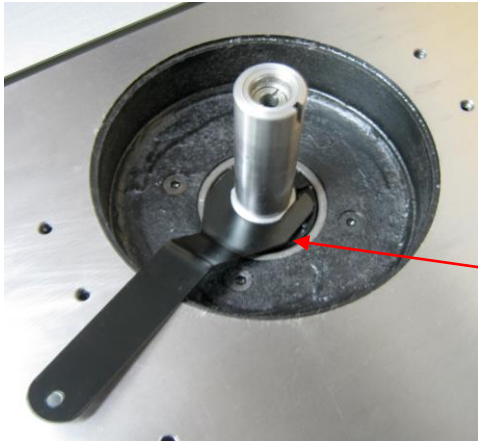

Warning: Failure to tighten the locking ring may result in the arbor and cutter block coming loose.

If the bolt holding the upper and tapered spindle together ever comes loose, it will be necessary to use the special spanner provided to hold the upper spindle in place whilst unlocking the top bolt.



The router collet is mounted in the same way.

When changing the router cutter, take the precaution of checking the centre retaining screw is tight

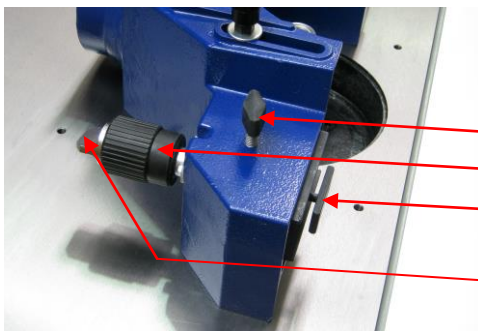

Assemble the fence;

Fence depth locking screw

Fence depth Adjusting screw.

Fence fixing plate.

Fence width lock.

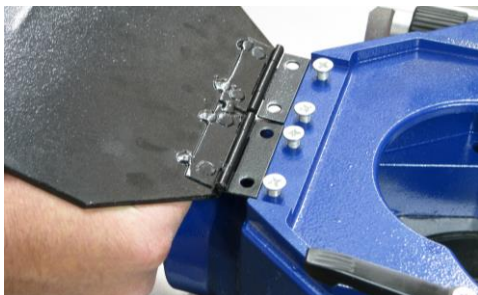

On top of the hood, you will find four screws. Remove the screws and attach the hinged top cover as shown below.

At the rear of the cutter hood is the connection for a 100mm diameter dust extraction hose to be fitted.

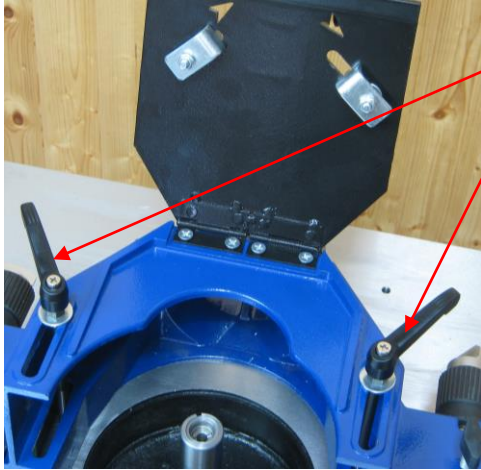

Fit the 2 long bolts through the slots in the hood and then screw them into a pair of holes in the table. The hood can be fixed in different positions depending on the size of the work piece.

The cover is hinged to provide quick access to the spindle to change the tooling.

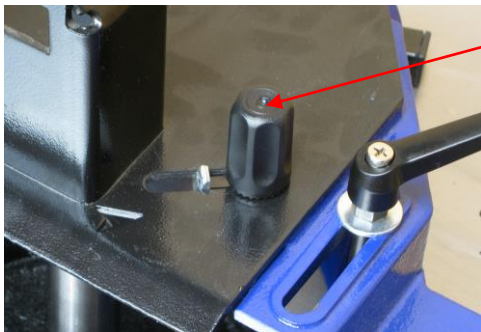

To lock the cover down, unscrew the locking knob, slide the clamp away from the centre of the hood so that the tongue fits under the hood, tighten the locking knob. Do the same on the other side.

This cover MUST be closed and locked when the machine is in operation.

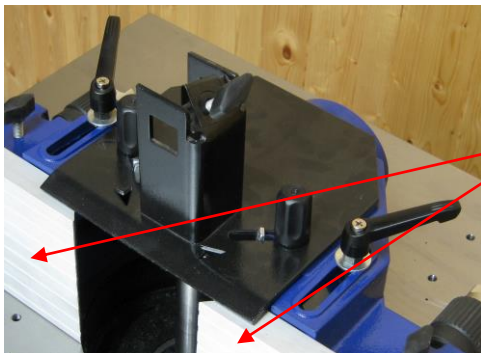

Loosen the fence depth locking thumbscrew, and the fence width lock, silver.

Slide the fence over the fixing plate, so that the mitred end of the fence is in the centre of the hood.

Wind the fence depth adjusting screw, so that the fence sits back against the hood, then lock it with the depth locking thumbscrew and the fence width lock.

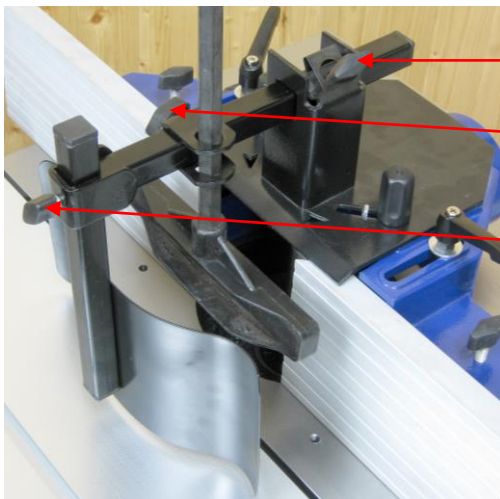

Assemble the front guard and clamp. Fit the square bar into the hood cover and lock it with the thumbscrew.

Slide the vertical hold down onto the square bar and lock it with the thumb screw.

Fit the front spring guard into the end of the square bar and lock it with the thumb screw.

With these correctly set, the work piece is held firmly against both the table and the fence.

Never operate the spindle moulder without them.



The end stop can be fitted as shown into the T-slot on the sliding carriage.

The angled shape makes it easier to keep larger workpieces flat on the table and suits rounded edges too.

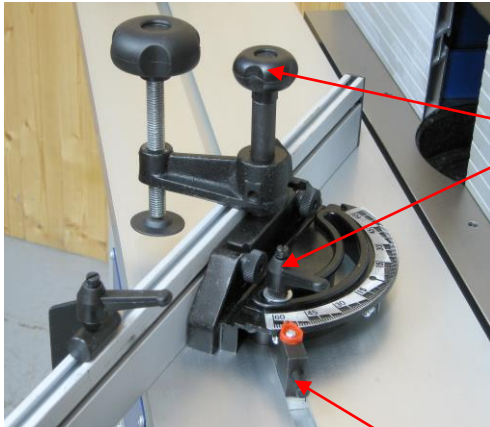

The crosscut fence and work clamp are assembled as shown.

Undo the main locking knob and the ratchet handle. Slide the base runner of the crosscut fence into the T-slot in the sliding carriage.

The crosscut fence may be adjusted up to 60 degrees in each direction. There are preset stops at 90 and 45 degrees each way. It is locked in place with the ratchet handle.



Pull the front pin out to move past the preset stops.

The long fence can be adjusted left and right to suit the diameter of tooling to be used.

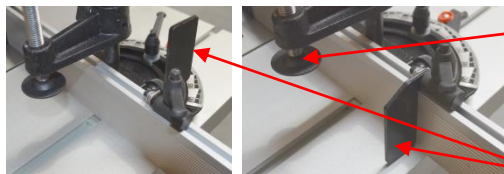

The work clamp can be used to clamp a work piece. Screw the thread down to engage the clamp.

The flip over length stop can be raised or lowered as shown.



Fitting a cutterblock

The cutter block (not included) is shown here assembled.

The larger of the two table inserts is fitted into the table aperture. Always fit the smallest table insert which the tooling allows.

A large selection of spacers, in varying widths are provided so that the cutter block can be located at the right height on the spindle.

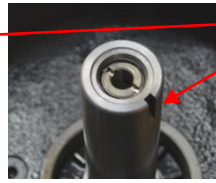

When stacking the spacers, ensure that the one with the roll pin is at the top of the stack and that the pin engages with the slot in the spindle. (Not all of the spacers will be required)

Before fitting the cutter block onto the spindle, engage the spindle lock.

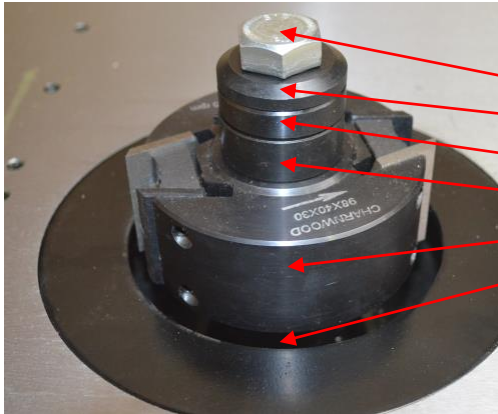

Now fit, (in reverse order):
 The locking bolt
 The top cap
 the spacer with the roll pin
 some spacers
 the cutter block
 some more spacers

The locking bolt must be firmly tightened.

Once the stack on the spindle is tight, release the spindle rotation lock, before starting the machine.

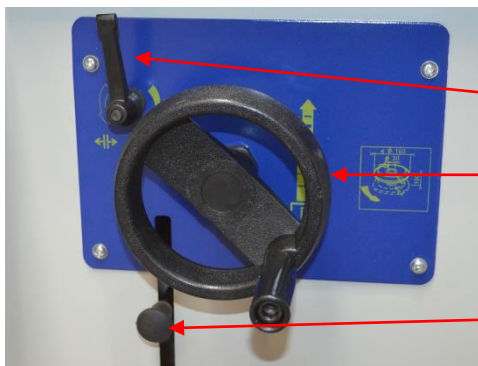

The Spindle Controls

Spindle Height Locking Lever

Rise and fall hand wheel.
 One complete turn raises or lowers the arbor by 2 mm (0.08").

Spindle Rotation Lock

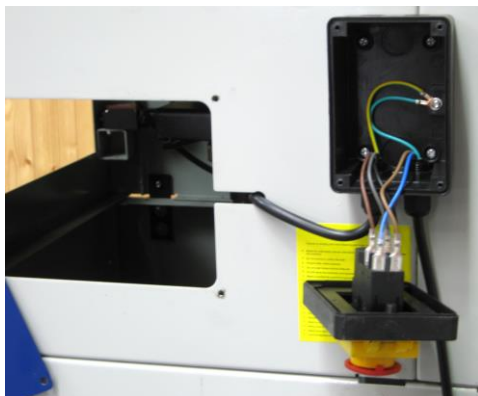

Fit the start/stop switch

Use a screwdriver to remove the blue panel on the front of the machine. Locate the switch and cable. Remove the front cover from the switch box. Then attach the back of the switch box to the machine using the four bolts, nuts and washers provided.

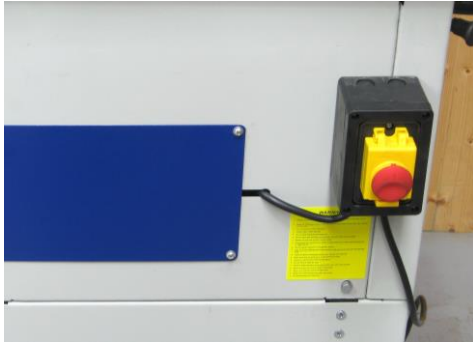

Re-fit the front cover of the switch.

Fit the cable into the slot and then re-fit the blue panel.

Changing Speed



The spindle moulder has 4 speeds.
To change speed;

Unscrew the knob and open this access door.
(The machine is fitted with a micro switch and will not run when this door is open)

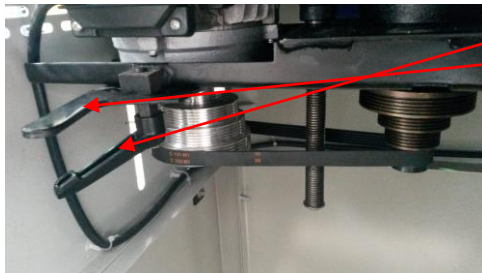

Slacken off the locking lever
Reduce the tension on the drive belt by moving this lever.
Move the drive belt to the pair of pulleys which give the required speed, re-tension the belt and then tighten the locking lever.

Operating the Spindle Moulder

It is assumed that anyone purchasing a spindle moulder has been trained to operate this type of machine competently. Such training is beyond the scope of this manual.

Spindle rotation speeds:

- 1500rpm - Drum Sanding *
- 4500rpm - Moulding Hardwoods
- 6500rpm - Moulding Softwoods
- 8500rpm - Routing *

* It should be noted that sanding and routing accessories are optional extras.

Limiters: Never use a cutter block without limiters fitted.

Fences: Close the two fences together so the edges are just missing the cutter. This improves the support for the work piece and is best practise for safety reasons.

Always adjust the fences so that the work is fully supported. If the cut removes the whole edge of the work piece, step the out-feed fence forward as appropriate.

Set the vertical hold down to contact the top of the work piece.

Set the front guard spring to hold the work piece up against the fences.

Use a push stick to feed small work pieces through the cutter block.

Always feed the work against the direction of rotation (from right to left).



Optional Accessories

CB9830 Cutterblock – This cutterblock set includes straight knives for rebating, plus 6 pairs of profile cutters with limiters. This cutterblock uses standard 40mm euro pattern cutters, which are widely available from specialist tooling manufacturers.



W520 Universal Wheel Base – Allows the machine to be easily moved around the workshop, simply by pressing the foot pedals.

Declaration of Conformity for CE Marking

Charnwood Declare that Woodworking Spindle Moulder, Model W040

Conforms with the following Directives: Machinery Directive 2006/42/EC
Low Voltage Directive 2006/95/EC
EMC Directive 2004/108/EC

And further conforms to the machinery example for which the EC type examination Certificate No., have been issued by TUV Rheinland LGA Products GmbH, Tillystrasse 2, 90431, Nurnberg.

I hereby declare that equipment named above has been tested and found to comply with the relevant sections of the above referenced specifications. The machinery complies with all essential requirements of the directive.

Signed:  Dated: Location: Leicestershire

Richard Cook, Director

Main Assembly – Diagram A

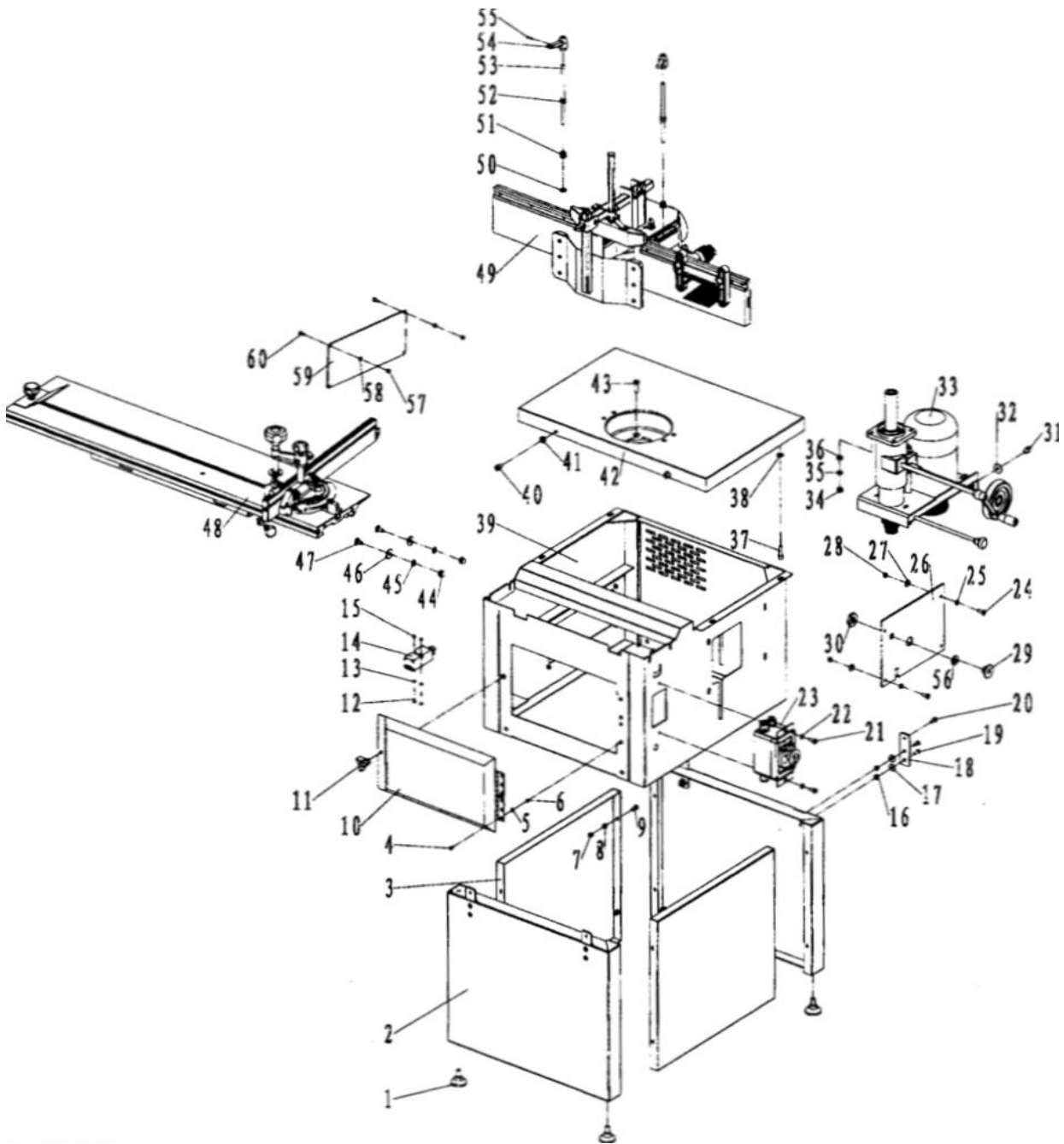

No.	Description	Qty		No.	Description	Qty
A01	Foot	4		A31	M8 x 25mm setscrew	1
A02	Front panel	1		A32	Washer	1
A03	L.H. panel	1		A33	Motor	1
A04	M4 x 10 mm setscrew	4		A34	M8 Nut	1
A05	Washer	5		A35	Spring washer	4
A06	M4 nut	4		A36	Washer	4
A07	M6 nut	8		A37	M8 x 25 mm setscrew	4
A08	Washer	8		A38	Washer	4
A09	M6 x 16 bolt	8		A39	Housing	1
A10	Access cover	1		A40	M8 x 12 mm setscrew	2
A11	Knob	1		A41	Washer	2
A12	M4 x 30mm setscrew	2		A42	Cast iron table	1
A13	Washer	2		A43	M8 x 30 mm setscrew	4
A14	Interlock switch	1		A44	Dome headed hex. nut	4
A15	M4 nut	2		A45	Locking washers	4
A16	M6 nut	8		A46	Large washer	4
A17	Washer	6		A47	M8 x 16 mm coach bolt	4
A18	Fishplate	4		A48	Sliding beam assy.	1
A19	M6 x 16 bolt	8		A49	Hood	1
A20	M6 x 12 bolt	4		A50	Washer	2
A21	M6 x 16 bolt	2		A51	M8 flange nut	2
A22	Washer	2		A52	M8 Nut	2
A23	NVR Switch	1		A53	Fixing bolt	2
A24	M6 x 16 bolt	4		A54	Bristol locking lever	2
A25	Washer	4		A55	Spring loaded pin	2
A26	Cover plate	1		A56	Bush	1
A27	Washer	4		A57	M5 nut	4
A28	Bush	1		A58	Washer	4
A29	Bush	1		A59	Cover plate	1
A30	Nut	1		A60	M5 x 12 setscrew	4

Motor and spindle assembly – Diagram B

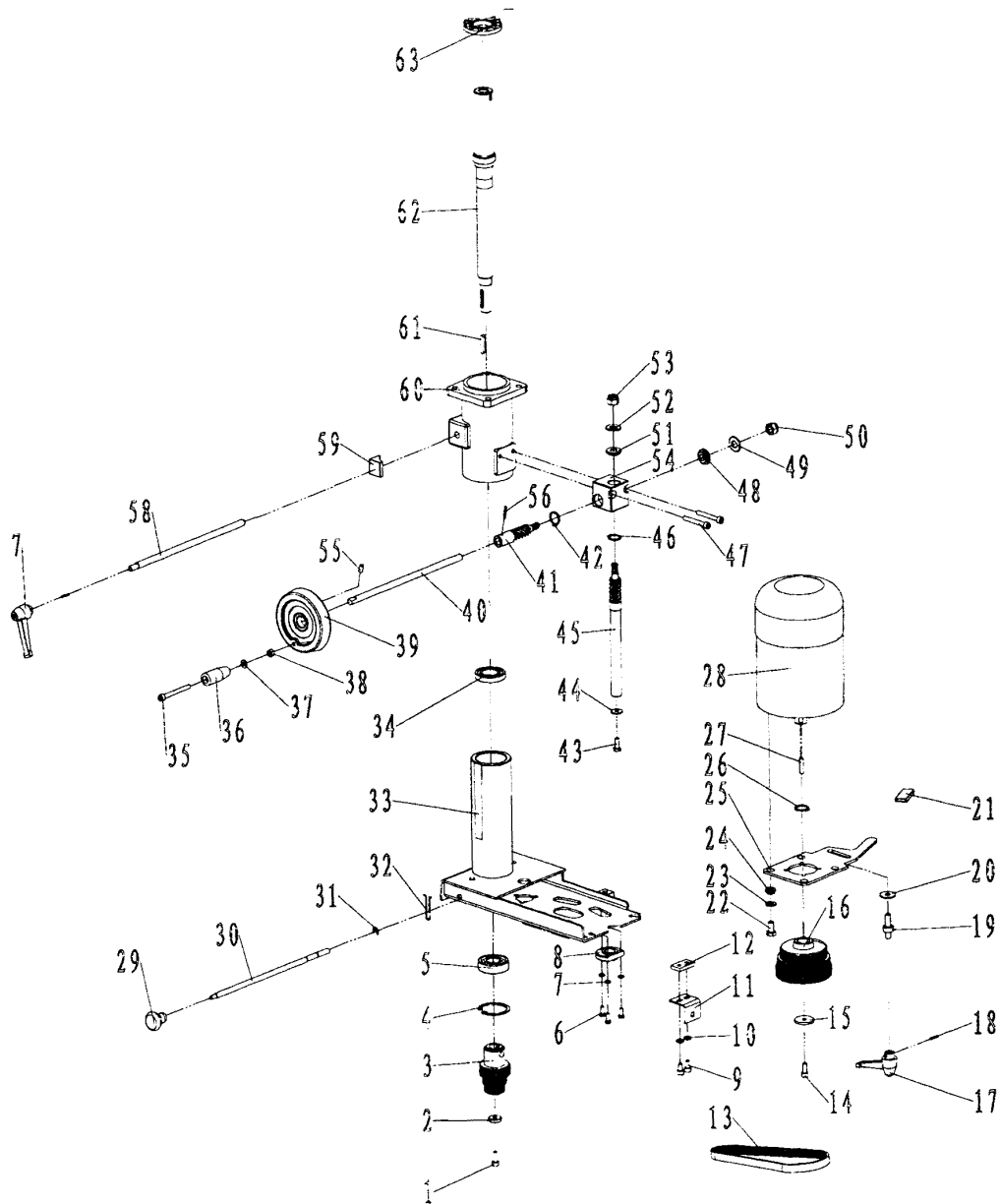

No.	Description	Qty	No.	Description	Qty
B01	Setscrew M6 x 16 mm	1	B33	Motor mount	1
B02	Washer	1	B34	Bearing	1
B03	Stepped pulley (driven)	1	B35	M6 x 60 mm setscrew	1
B04	Circlip	1	B36	Handle	1
B05	Bearing	1	B37	Washer	1
B06	M5 x 12 mm bolt	3	B38	M6 nut	1
B07	Washer	3	B39	Hand wheel	1
B08	Bush	1	B40	Shaft	1
B09	M6 x 9mm setscrew	2	B41	Threaded shaft extension	1
B10	Washer	2	B42	Circlip	1
B11	Angle bracket	1	B43	M6 x 16 setscrew	1
B12	Fishplate	1	B44	Washer	1
B13	Drive belt	1	B45	Rise & fall shaft	1
B14	M6 x 16 setscrew	1	B46	Circlip	1
B15	Washer	1	B47	M6 x 45 setscrew	2
B16	Motor pulley (stepped)	1	B48	Bush	1
B17	Bristol locking lever	1	B49	Bearing	1
B18	Spring loaded pin	1	B50	Self locking nut	1
B19	Bolt	1	B51	Bush	1
B20	Washer	1	B52	Bearing	1
B21	Rectangular nut	1	B53	M10 self locking nut	1
B22	M8 x 16 mm bolt	4	B54	Gearbox	1
B23	Washer	4	B55	M6 x 12 setscrew	1
B24	Bush	4	B56	Spring loaded pin	1
B25	Motor arm	1	B57	Locking handle	1
B26	Circlip	1	B58	Shaft	1
B27	Key	1	B59	Friction block	1
B28	Motor	1	B60	Top bearing	1
B29	Knob	1	B61	Key	1
B30	Spindle lock shaft	1	B62	Spindle	1
B31	Circlip	1	B63	Cap	1
B32	Spring clip	1			

Fence / Hood Assembly – Diagram C

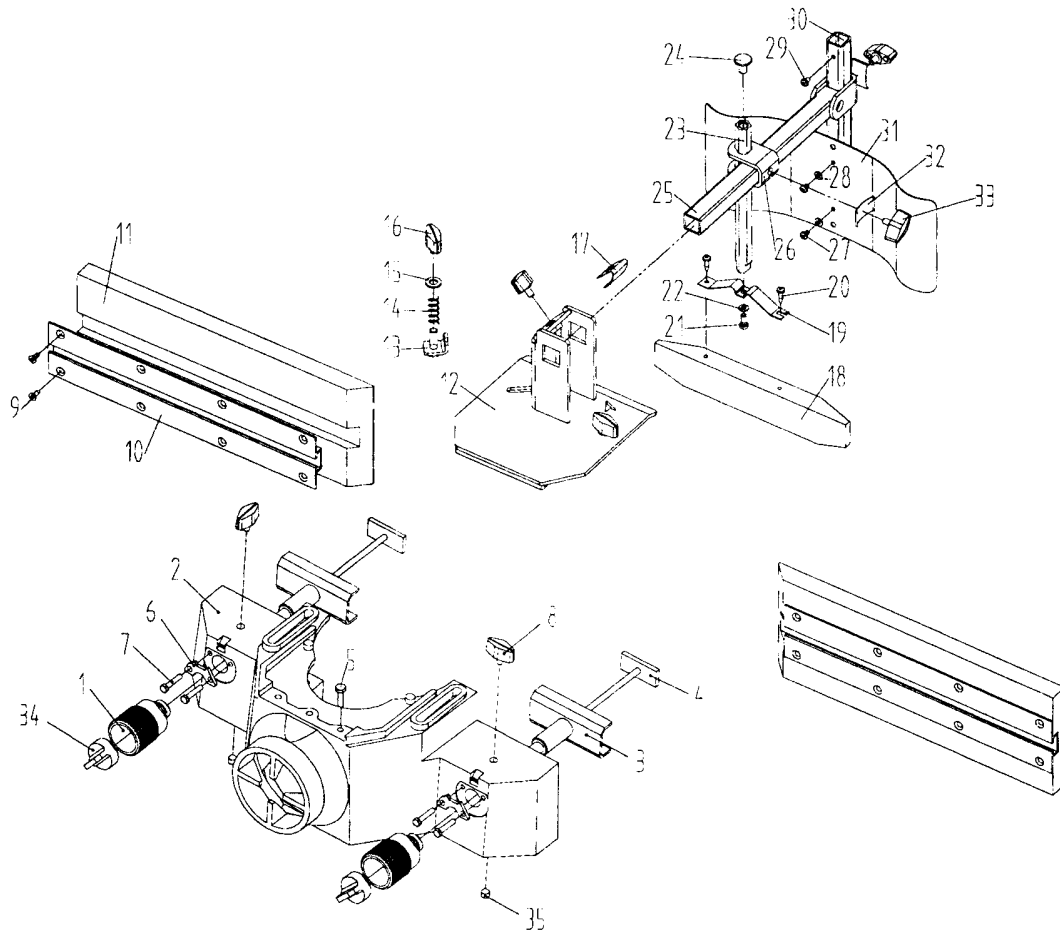

No.	Description	Qty	No.	Description	Qty
C01	Fence fore & aft adjuster	2	C19	n/a	
C02	Cutter hood	1	C20	n/a	
C03	Fence backing plate	2	C21	n/a	
C04	Flange headed bolt	2	C22	n/a	
C05	Setscrew	4	C23	Hold down column	1
C06	Semicircular locking plate	2	C24	Plastic cap	1
C07	M4 x 12 mm bolt	4	C25	Feather-board arm	1
C08	Fence locking screw	2	C26	C clamp	1
C09	n/a		C27	M4 x 6 mm setscrew	2
C10	n/a		C28	Washer	2
C11	Fence	2	C29	M4 x 6 mm setscrew	1
C12	Cover plate	1	C30	Feather-board column	1
C13	Clamp	2	C31	Feather-board	1
C14	Spring	2	C32	Spring	1
C15	Washer	2	C33	Locking screw	1
C16	Locking screw	2	C34	Locking knob	2
C17	Spring	2	C35	n/a	
C18	Hold down	1			

Sliding Beam Assembly – Diagram D

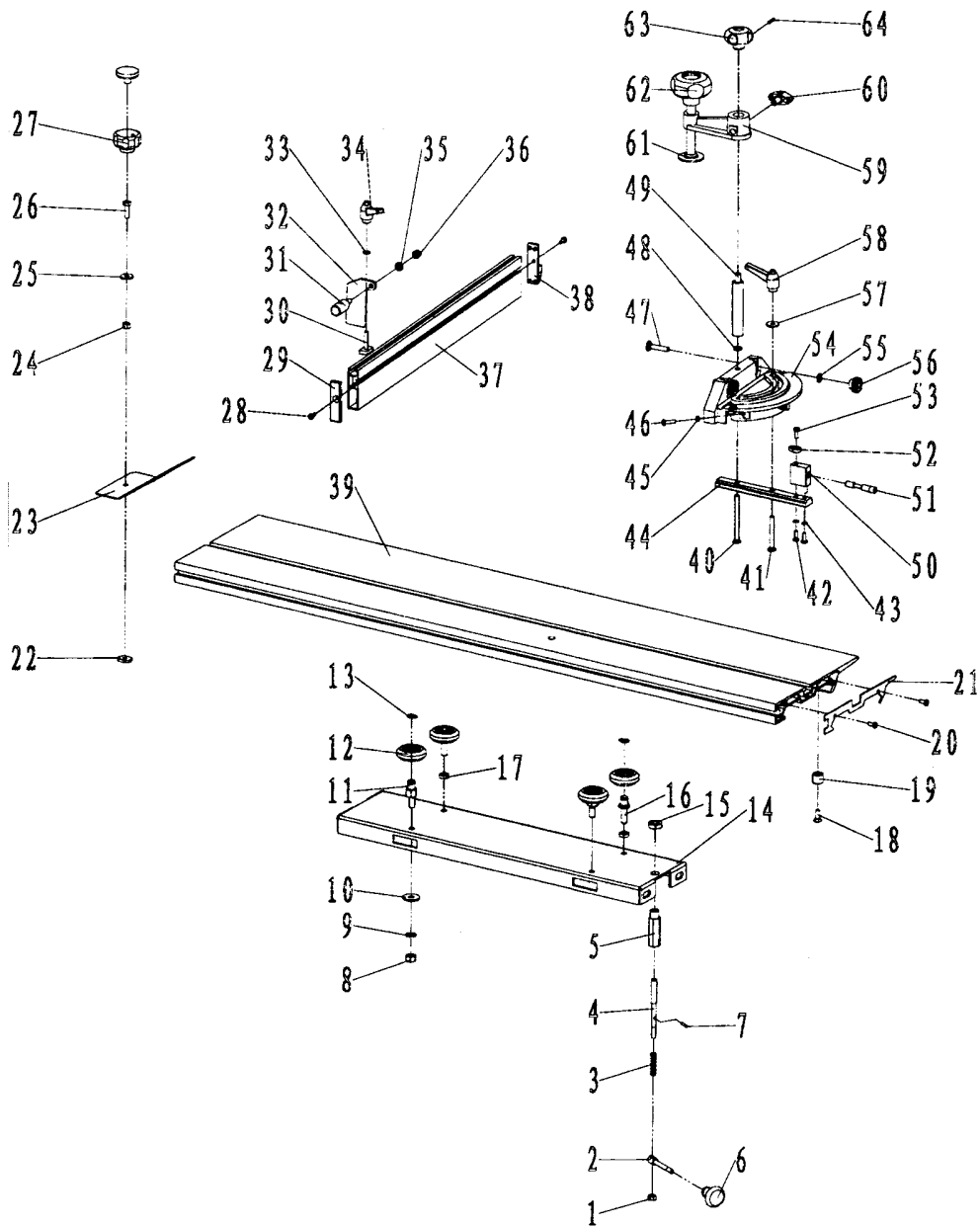

No.	Description	Qty	No.	Description	Qty
D01	M6 nut	1	D33	Washer	1
D02	Horizontal shaft	1	D34	Knob	1
D03	Spring	1	D35	Washer	1
D04	Stop	2	D36	M6 self locking nut	1
D05	Bush	1	D37	Fence	1
D06	Knob	1	D38	End cap	1
D07	Spring loaded pin	1	D39	Sliding beam	1
D08	M8 nut	1	D40	M6 x 70 setscrew	1
D09	Lock washer	2	D41	M6 x 50 setscrew	1
D10	Washer	2	D42	M4 x 12 setscrew	2
D11	Eccentric axle	2	D43	Spring washer	2
D12	Guide wheel	4	D44	T-bar	1
D13	Circlip	4	D45	M4 nut	3
D14	Beam carrier	1	D46	M4 x 16 setscrew	3
D15	M12 nut	1	D47	n/a	
D16	Concentric axle	2	D48	Washer	1
D17	M8 nut	2	D49	Spindle	1
D18	M6 x 16 mm setscrew	2	D50	Pointer support	1
D19	Nylon bush	2	D51	Retractable pin	1
D20	M4 x 10 mm setscrew	4	D52	Pointer	1
D21	Beam end piece	2	D53	M4 x 12 setscrew	1
D22	Square nut	1	D54	Mitre gauge	1
D23	End stop	1	D55	n/a	
D24	M6 nut	1	D56	n/a	
D25	Washer	1	D57	Washer	1
D26	M6 x 20 mm setscrew	1	D58	Bristol locking lever	1
D27	Knob	1	D59	Clamp arm	1
D28	M4 x 10mm setscrew	2	D60	Knob	1
D29	End cap1	1	D61	Pressure plate	1
D30	Tee-bolt	1	D62	Knob	1
D31	Bolt	1	D63	Knob	1
D32	Flip-over end stop	1	D64	Roll pin	1



Woodworking machinery at its best!

**Charnwood, Cedar Court, Walker Road,
Hilltop Industrial Estate, Bardon Hill, Leicestershire, LE67 1TU**

Tel. 01530 516 926 Fax. 01530 516 929
email: sales@charnwood.net website: www.charnwood.net