

KS 18 LTX 57 KS 18 LTX 57 BL

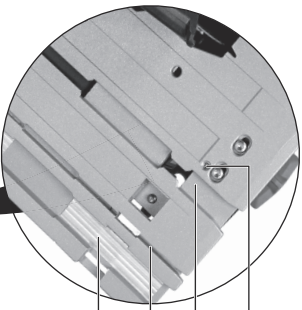

de	Originalbetriebsanleitung 5	fi	Alkuperäiskäyttöohje 53
en	Original operating instructions 11	no	Original instruksjonsbok 59
fr	Instructions d'utilisation originales 17	da	Original brugsvejledning 65
nl	Originele gebruiksaanwijzing 23	pl	Originalna instrukcja obsługi 71
it	Manuale d'uso originale 29	el	Πρωτότυπο οδηγιών λειτουργίας 77
es	Manual de instrucciones original 35	hu	Eredeti használati utasítás 84
pt	Manual de instruções original 42	ru	Оригинальное руководство по эксплуатации 90
sv	Original bruksanvisning 48	uk	Оригінальна інструкція з експлуатації 98

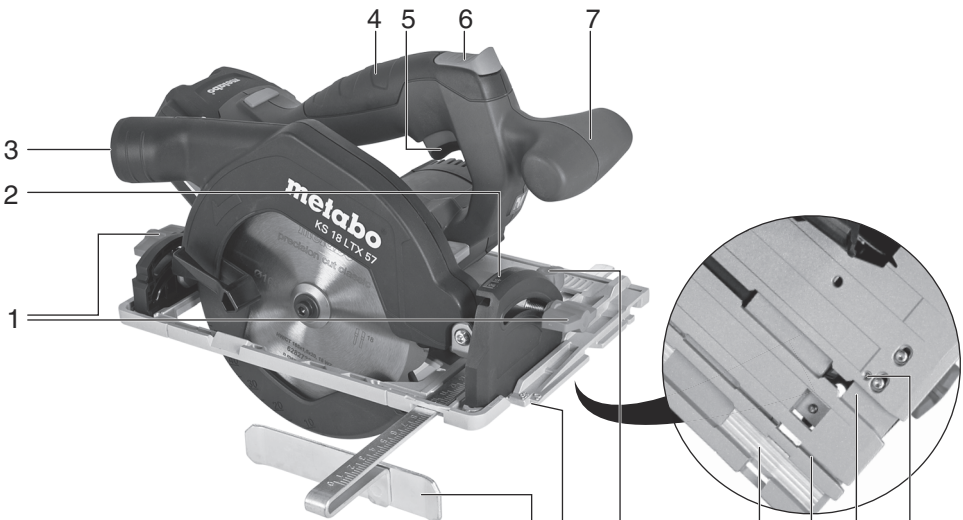

- 9
- 8
- Metabo
- Mafell / Bosch
- Metabo / Hitachi / Festool / Makita / Hilti

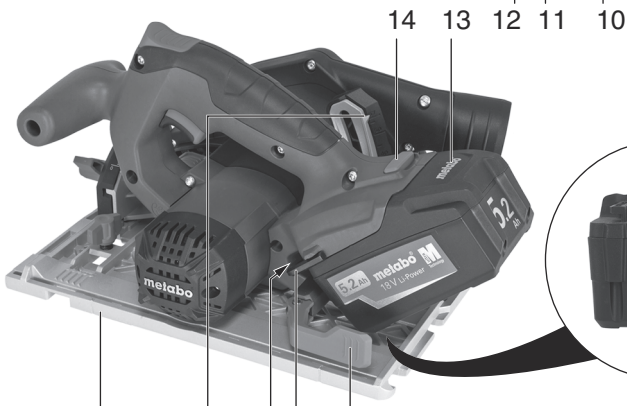

- 15
- 16
- 17
- 18
- 19
- 20
- 21
- 22

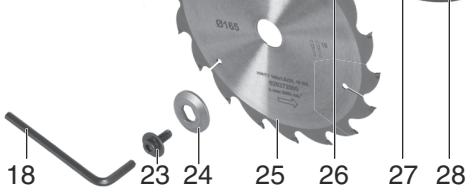
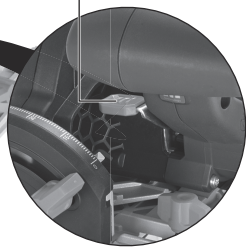
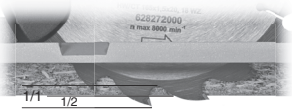

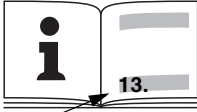
		KS 18 LTX 57 *1) Serial Number: 01857..	KS 18 LTX 57 BL *1) Serial Number: 11857..
U	V	18	18
n_0	/min	4600	5000
T_{max}	min (in)	57 (2 1/4")	57 (2 1/4")
T_{90°	mm (in)	57 (2 1/4")	57 (2 1/4")
T_{45°	mm (in)	43 (1 11/16")	43 (1 11/16")
A	°	0° - 50°	0° - 50°
\emptyset	mm (in)	165 (6 1/2")	165 (6 1/2")
d	mm (in)	20 (25/832")	20 (25/832")
a	mm (in)	max. 1,7 (max. 0.067")	max. 1,7 (max. 0.067")
b	mm (in)	max. 2,6 (max. 0.102")	max. 2,6 (max. 0.102")
m	kg (lbs)	3,4 (7.5)	3,6 (7.9)
$a_{h,D}/K_{h,D}$	m/s^2	< 2,5 / 1,5	< 2,5 / 1,5
L_{pA}/K_{pA}	dB (A)	92 / 3	94 / 3
L_{WA}/K_{WA}	dB (A)	103 / 3	102 / 3

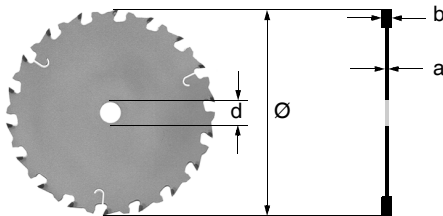

CE *2) 2014/30/EU, 2006/42/EC, 2011/65/EU
*3) EN 62841-1:2015+A11:2022, EN 62841-2-5:2014, EN IEC 63000:2018

2022-08-01 Bernd Fleischmann
Direktor Produktentstehung & Qualität (Vice President Product Engineering & Quality)
*4) Metabowerke GmbH - Metabo-Allee 1 - 72622 Nuertingen, Germany

ppa. B.F.

(A)



628028000

(B)

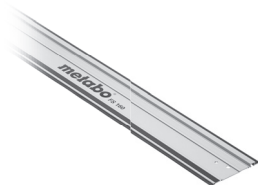

FS 80	629010000
FS 160	629011000
FS 250	629013000
FS 310	629014000

(C)



KFS 30	629015000
KFS 44	629016000
KFS 70	629017000

(D)



629021000

(E)



165x20	Z18 WZ 20°	628294000
165x20	Z36 WZ 15°	628295000
165x20	Z18 WZ 20°	628272000

(F)



ASC 145 etc.

(G)



18 V	5,5 Ah	625368000	LiHD
18 V	8,0 Ah	625369000	LiHD
18 V	10,0 Ah	625549000	LiHD

etc.

(H)



6.31362
Ø 35 mm, 3,5 m



6.31939
Ø 27 mm, 3,5 m, antistatic

Original operating instructions

1. Declaration of Conformity

We hereby declare under our sole responsibility that these cordless hand-held circular saws, identified by type and serial number *1), meet all relevant requirements of directives *2) and standards *3). Technical documents for *4) - see page 3.

For UK only:

UK We as manufacturer and authorized person to
CA compile the technical file, see *4) on page 3, hereby declare under sole responsibility that these cordless hand-held circular saws, identified by type and serial number *1) on page 3, fulfill all relevant provisions of following UK Regulations S.I. 2016/1091, S.I. 2008/1597, S.I. 2012/3032 and Designated Standards EN 62841-1:2015+A11:2022, EN 62841-2-5:2014, EN IEC 63000:2018

2. Specified Conditions of Use

The hand-held circular saw is suitable for sawing wood, plastics and other similar materials.

The machine is not designed for plunge cuts.

The user bears sole responsibility for any damage caused by inappropriate use.

Generally accepted accident prevention regulations and the enclosed safety information must be observed.

3. General Safety Information



For your own protection and for the protection of your electrical tool, pay attention to all parts of the text that are marked with this symbol!



WARNING – Reading the operating instructions will reduce the risk of injury.



WARNING – Read all safety warnings, instructions, illustrations and specifications provided with this power tool. Failure to follow all instructions listed below may result in electric shock, fire and/or serious injury.

Save all warnings and instructions for future reference. Pass on your electrical tool only together with these documents.

4. Special Safety Instructions

Cutting procedure



a) **DANGER: Keep hands away from cutting area and the blade. Keep your second hand on auxiliary handle, or motor housing.** If both hands are holding the saw, they cannot be cut by the blade.

b) **Do not reach underneath the workpiece.** The guard cannot protect you from the blade below the workpiece.

c) **Adjust the cutting depth to the thickness of the workpiece.** Less than a full tooth of the blade teeth should be visible below the workpiece.

d) **Never hold the workpiece in your hands or across your leg while cutting. Secure the workpiece to a stable platform.** It is important to support the work properly to minimise body exposure, blade binding, or loss of control.

e) **Hold the power tool by insulated gripping surfaces, when performing an operation where the cutting tool may contact hidden wiring or its own cord.** Contact with a "live" wire will also make exposed metal parts of the power tool "live" and could give the operator an electric shock.

f) **When ripping, always use a rip fence or straight edge guide.** This improves the accuracy of cut and reduces the chance of blade binding.

g) **Always use blades with correct size and shape (diamond versus round) of arbour holes.** Blades that do not match the mounting hardware of the saw will run off-centre, causing loss of control.

h) **Never use damaged or incorrect blade washers or bolt.** The blade washers and bolt were specially designed for your saw, for optimum performance and safety of operation.

Kickback causes and related warnings.

- kickback is a sudden reaction to a pinched, jammed or misaligned saw blade, causing an uncontrolled saw to lift up and out of the workpiece toward the operator;
- when the blade is pinched or jammed tightly by the kerf closing down, the blade stalls and the motor reaction drives the unit rapidly back toward the operator;
- if the blade becomes twisted or misaligned in the cut, the teeth at the back edge of the blade can dig into the top surface of the wood causing the blade to climb out of the kerf and jump back toward the operator.

Kickback is the result of saw misuse and/or incorrect operating procedures or conditions and can be avoided by taking proper precautions as given below.

a) **Maintain a firm grip with both hands on the saw and position your arms to resist kickback forces. Position your body to either side of the blade, but not in line with the blade.** Kickback could cause the saw to jump backwards, but kickback forces can be controlled by the operator, if proper precautions are taken.

b) **When blade is binding, or when interrupting a cut for any reason, release the trigger and hold the saw motionless in the material until the blade comes to a complete stop. Never attempt to remove the saw from the work or pull the saw backward while the blade is in motion or kickback may occur.** Investigate and take corrective actions to eliminate the cause of blade binding.

c) **When restarting a saw in the workpiece, centre the saw blade in the kerf so that the saw**

teeth are not engaged into the material. If a saw blade binds, it may walk up or kickback from the workpiece as the saw is restarted.

d) **Support large panels to minimise the risk of blade pinching and kickback.** Large panels tend to sag under their own weight. Supports must be placed under the panel on both sides, near the line of cut and near the edge of the panel.

e) **Do not use dull or damaged blades.** Unsharpened or improperly set blades produce narrow kerf causing excessive friction, blade binding and kickback.

f) **Blade depth and bevel adjusting locking levers must be tight and secure before making the cut.** If blade adjustment shifts while cutting, it may cause binding and kickback.

g) **Use extra caution when sawing into existing walls or other blind areas.** The protruding blade may cut objects that can cause kickback.

Lower guard function

a) **Check the lower guard for proper closing before each use. Do not operate the saw if the lower guard does not move freely and close instantly. Never clamp or tie the lower guard into the open position.** If the saw is accidentally dropped, the lower guard may be bent. Raise the lower guard with the retracting handle (26) and make sure it moves freely and does not touch the blade or any other part, in all angles and depths of cut.

b) **Check the operation of the lower guard spring. If the guard and the spring are not operating properly, they must be serviced before use.** Lower guard may operate sluggishly due to damaged parts, gummy deposits, or a build-up of debris.

c) **The lower guard may be retracted manually only for special cuts such as "plunge cuts" and "compound cuts". Raise the lower guard by the retracting handle (26) and as soon as the blade enters the material, the lower guard must be released** For all other sawing, the lower guard should operate automatically.

d) **Always observe that the lower guard is covering the blade before placing the saw down on bench or floor.** An unprotected, coasting blade will cause the saw to walk backwards, cutting whatever is in its path. Be aware of the time it takes for the blade to stop after switch is released.

Do not use sanding discs.

Keep hands away from the rotating tool! Remove chips and similar material only with the machine at a standstill.



Wear a suitable dust protection mask.



Wear ear protectors.



Wear protective goggles.

Press the spindle locking button only when the motor is at a standstill.

Do not reduce the speed of the saw blade by pressing on the sides.

The movable guard must not be clamped in the pulled-back position for sawing.

The movable guard must move freely, automatically, easily and exactly back into its end position.

When sawing materials that generate large quantities of dust, the machine must be cleaned regularly. Make sure that the safety appliances, e.g. the movable guard, are in perfect working order.

Materials that generate dusts or vapours that may be harmful to health (e.g. asbestos) must not be processed.

Check the workpiece for foreign bodies. When working, always make sure that no nails or other similar materials are being sawed into.

If the saw blade blocks, turn the motor off immediately.

Do not try to saw extremely small workpieces.

During machining, the workpiece must be firmly supported and secured against moving.

Clean gummy or glue-contaminated saw blades. Contaminated saw blades cause increased friction, jamming of the saw blade and increase the risk of back-kicks.

Avoid overheating of the saw tooth tips. Avoid melting of the material when sawing plastic.

Use a saw blade that is suitable for the material being sawn.

If the machine is defective, remove the battery pack from the machine.



Protect battery packs from water and moisture!

Do not use faulty or deformed battery packs!



Do not expose battery packs to fire!

Do not open battery packs!

Do not touch or short circuit battery pack contacts!

Remove the battery pack from the machine when not in use.

Remove the battery pack from the machine before any adjustment or maintenance is carried out.

Before fitting the battery pack, make sure that the machine is switched off.



A slightly acidic, flammable fluid may leak from defective Li-ion battery packs!



If battery fluid leaks out and comes into contact with your skin, rinse immediately with plenty of water. If battery fluid leaks out and comes into contact with your eyes, wash them with clean water and seek medical attention immediately!

Transport of li-ion battery packs:

The shipping of li-ion battery pack is subject to laws related to the carriage of hazardous goods (UN 3480 and UN 3481). Inform yourself of the currently valid specifications when shipping li-ion battery packs. If necessary, consult your freight forwarder. Certified packaging is available from Metabo.

Only send the battery pack if the housing is intact and no fluid is leaking. Remove the battery pack from the machine for sending. Prevent the contacts from short-circuiting (e.g. by protecting them with adhesive tape).

Reducing dust exposure:

 **WARNING** - Some dust created by power sanding, sawing, grinding, drilling, and other construction activities contains chemicals known to cause cancer, birth defects or other reproductive harm. Some examples of these chemicals are:

- Lead from lead-based paints,
- Crystalline silica from bricks and cement and other masonry products, and
- Arsenic and chromium from chemically treated lumber.

Your risk from these exposures varies, depending on how often you do this type of work. To reduce your exposure to these chemicals: work in a well ventilated area, and work with approved safety equipment, such as those dust masks that are specially designed to filter out microscopic particles.

This also applies to dust from other materials such as some timber types (like oak or beech dust), metals, asbestos. Other known diseases are e.g. allergic reactions, respiratory diseases. Do not let dust enter the body.

Observe the relevant guidelines and national regulations for your material, staff, application and place of application (e.g. occupational health and safety regulations, disposal).

Collect the particles generated at the source, avoid deposits in the surrounding area.

Use suitable accessories for special work. In this way, fewer particles enter the environment in an uncontrolled manner.

Use a suitable extraction unit.

Reduce dust exposure with the following measures:

- do not direct the escaping particles and the exhaust air stream at yourself or nearby persons or on dust deposits,
- use an extraction unit and/or air purifiers,
- ensure good ventilation of the workplace and keep clean using a vacuum cleaner. Sweeping or blowing stirs up dust.
- Vacuum or wash the protective clothing. Do not blow, beat or brush.

5. Overview

See page 2.

- 1 Locking screw (diagonal cuts)
- 2 Scale (diagonal cut angle)
- 3 Connector (extraction connection piece / chip ejection)

- 4 Handle
- 5 Trigger
- 6 Locking button
- 7 Handle
- 8 Adjusting screw (adjust saw disc angle)
- 9 3 Guide grooves to place the machines on guide tracks from different manufacturers
- 10 Locking screw (parallel guide)
- 11 Cutting indicator
- 12 Parallel stop
- 13 Battery pack
- 14 Battery pack release button
- 15 Guide plate
- 16 Scale (depth of cut)
- 17 Storage for hexagon wrench
- 18 Hexagon wrench
- 19 Locking lever (depth of cut)
- 20 Capacity and signal indicator
- 21 Capacity indicator button
- 22 Spindle locking button
- 23 Saw blade fixing screw
- 24 Outer saw blade flange
- 25 Saw blade
- 26 Lever (swivelling back the movable guard)
- 27 Inner saw blade flange
- 28 Movable safety guard

6. Initial Operation and Setting

 Remove the battery pack from the machine before any adjustment or maintenance is carried out. Make sure that the tool is switched off before fitting the battery pack.

6.1 Battery pack

Charge the battery pack (13) before use.

Recharge the battery pack if performance diminishes.

Instructions on charging the battery pack can be found in the operating instructions of the Metabo charger.

Li-ion battery packs “Li-Power, LiHD“ have a capacity and signal indicator (20):

- Press the button (21); the LEDs indicate the charge level.
- The battery pack is almost flat and must be recharged if one LED is flashing.

Removal:

Press the battery pack release (14) button and pull the battery pack (13) **upwards**.

Inserting:

Slide in the battery pack (13) until it engages.

6.2 Setting cutting depth

Loosen the locking lever (19) for adjustment. Read the depth of cut that has been set from the scale (16). Tighten the locking screw again.

It is advisable to set the depth of cut in such a way that no more than half of each tooth on the saw

blade juts out under the workpiece. See illustration on page 3.

6.3 Slanting saw blade for diagonal cuts

Loosen the locking screws (1). Tilt the motor part against the guide plate (15). Read the angle which has been set from the scale (2). Tighten the locking screws again.

6.4 Correcting the saw disc angle

If, at 0°, the saw blade is not at right angles to the guide plate: use the adjustment screw (8) to correct the saw blade angle.

6.5 Extractor connection piece

Sawdust extraction

To extract the sawdust, connect a suitable extraction unit with suction hose to the extraction adapter (3).

7. Use

7.1 The machine's multifunctional monitoring system

 If the machine switches off automatically, the machine electronics have activated automatic protection mode. A warning signal sounds (continuous beeping). The beeping stops after a maximum of 30 seconds or when the trigger switch (5) is released.

 In spite of this protective function, overloading is still possible with certain applications and can result in damage to the machine.

Causes and remedies:

1. **Battery pack almost flat** (the electronics prevent the battery pack from discharging totally and avoid irreparable damage).

If one LED (20) is flashing, the battery pack is almost flat. If necessary, press the button (21) and check the LEDs (20) to see the charge level. If the battery pack is almost flat, it must be recharged.

2. Long continuous overloading of the machine will activate the **temperature cut-out**.

The machine continues to run with reduced performance until the temperature is back to normal.

In case of excessive overheating, the machine will switch off completely.

Leave the machine or battery pack to cool.

Note: If the battery pack feels very warm, the pack will cool more quickly in your "AIR COOLED" charger.

Note: The machine will cool more quickly if you operate it at idling speed.

3. If the **current is too high** (for example, if the machine seizes continuously for long periods), the machine switches off.

Switch off the machine at the trigger switch (5). Then continue working as normal (in this case, read in particular the safety instructions in

Chapter 4...Kickback... in addition to all other safety instructions). Try to prevent the machine from seizing.

7.2 Switching on and off

Switching on: Push the locking button (6) forwards and hold, then actuate the trigger (5).

Switching off: Release the trigger switch (5).

7.3 Working Directions

 Do not switch the machine on or off while the saw blade is touching the workpiece.

 Let the saw blade reach its full speed before making a cut.

When the hand-held circular saw is added, the movable guard is swung backwards by the workpiece.

 When sawing, never remove the machine from the material with the saw blade turning. Allow the saw blade to come to a standstill.

 If the saw blade blocks, turn the machine off immediately.

 Do not set the machine down until the saw blade has come to a standstill.

Sawing along a straight line: the cutting indicator is used here (11). The left notch (marked 0°) indicates the direction of the cut if the saw blade is held vertically. The right notch (marked 45°) indicates the direction of the cut if the saw blade is held at 45°.

Sawing along a rail secured on the workpiece: In order to achieve an exact cutting edge, you can attach a rail to the workpiece and then guide the hand-held circular saw by means of the guide plate along this rail.

Sawing with parallel guide:

For cuts parallel to a straight edge. The parallel guide (12) can be inserted from either side into the support provided for it. Tighten the locking screw (10). It is best to calculate the exact cut width by making a test cut.

Sawing with guide rail 6.31213:

For dead straight, tear-free cutting edges with millimetre precision. The anti-slip coating keeps the surface safe and protects the workpiece against scratches. For guide rail 6.31213, see chapter on Accessories.

Battery pack heat generation:

Under extremely hard application conditions (e.g. sawing thick wooden planks), the heavy load can cause the battery pack to heat (> 60 °C). To conserve the battery pack, allow it to cool down before continuing work.

8. Maintenance

Changing saw blades

 The saw blade must be stationary.

 Remove battery pack from machine.

-  Risk of injury, even with the blade at standstill. Wear protective gloves.

Press in the spindle locking button (22) and hold in place. Turn the saw spindle slowly with the spanner in the saw blade fixing screw (23) (18) until the lock catches.

Unscrew the saw blade fixing screw in anti-clockwise direction and remove the outer saw blade flange (24). Pull back the movable guard (28) and remove the saw blade.

-  Ensure that the inner saw blade flange (27) is inserted in the right way: The inner saw blade flange (27) has 2 sides, diameter 20 mm and 5/8" (16 mm). Ensure a precise fit of saw blade mounting hole to the inner saw blade flange (27)! Incorrectly installed saw blades do not run smoothly and lead to loss of control.

Insert a new saw blade, Make sure the direction of rotation is correct. The direction of rotation is indicated by arrows on the saw blade and guard. The contact areas between the inner saw blade flange (27), the saw blade (25), the outer saw blade flange (24) and the saw blade fixing screw (23) must be clean.

Put on the outer saw blade flange (24). Ensure that the outer saw blade flange (24) is inserted the correct way round (inscription facing outwards).

Tighten the saw blade fixing screw (23) using a hexagon wrench (18) (**max. 5 Nm**).

-  Use only sharp, undamaged saw blades. Do not use saw blades that are cracked or that have changed their shape.

-  Do not use any saw blades made from high-alloy high-speed steel (HSS).

-  Do not use any saw blades which do not conform to the specified rating. Use only saw blades with a diameter according to the markings on the saw.

-  The saw blade must be suitable for the no-load speed.

-  Use a saw blade that is suitable for the material being sawn.

-  Use only genuine Metabo - saw blades. Saw blades intended for cutting wood or similar materials have to conform to EN 847-1.

9. Cleaning

-  Remove battery pack from machine.

Dust deposits must be regularly removed from the machine. This includes cleaning the ventilation slits on the motor with a vacuum cleaner. Make sure that the safety appliances, e.g. the movable guard, are in perfect working order.

10. Accessories

Use only original Metabo or CAS (Cordless Alliance System) battery packs and accessories.

Use only accessories that fulfil the requirements and specifications listed in these operating instructions.

See page 4.

- A Dust bag
- B Guide rail
- C Mitre rail
- D Fast-action clamp clip. To secure the guide rail.
- E Circular saw blades. For clean cutting results for straight and cross cuts in soft and hard wood.
- F Battery charger
- G Battery packs with different capacities. Only buy battery packs only with voltage suitable for your power tool
- H Metabo universal vacuum cleaner
- I Suction hose

For a complete range of accessories, see www.metabo.com or the catalogue.

11. Repairs

-  Repairs to power tools must only be carried out by qualified electricians!

Contact your local Metabo representative if you have Metabo power tools requiring repairs. See www.metabo.com for addresses.

You can download a list of spare parts from www.metabo.com.

12. Environmental Protection

Observe national regulations on environmentally compatible disposal and on the recycling of disused machines, packaging and accessories.

Packaging materials must be disposed of according to their labelling in accordance with municipal guidelines. Further information can be found at www.metabo.com in the "Service" section.

-  Only for EU countries: never dispose of power tools in your household waste! According to European Directive 2012/19/EU on Waste from Electric and Electronic Equipment and implementation in national law, used power tools must be collected separately and recycled in an environmentally-friendly manner.

Battery packs may not be disposed of with regular waste. Return faulty or used battery packs to your Metabo dealer!

Do not allow battery packs to come into contact with water!

Discharge the battery pack in the power tool before disposal. Prevent the contacts from short-circuiting (e.g. by protecting them with adhesive tape).

13. Technical Specifications

Explanatory notes on the specifications on page 3. Changes due to technological progress reserved.

- U = Voltage of battery pack
- n_0 = idle speed

en ENGLISH

T_{\max}	= maximum depth of cut
T_{90°	= adjustable depth of cut (90°)
T_{45°	= adjustable depth of cut (45°)
A	= adjustable angular cut angle
\varnothing	= saw blade diameter
d	= saw blade drill diameter
a	= max. base body thickness of the saw blade
b	= max. cutting width of saw blade
m	= weight

Measured values determined in conformity with EN 62841.

Permitted ambient temperature during operation: -20 °C to 50 °C (limited performance with temperatures below 0 °C). Permitted ambient temperature for storage: 0 °C to 30 °C

== Direct current

The technical specifications quoted are subject to tolerances (in compliance with the relevant valid standards).



Emission values

These values make it possible to assess the emissions from the power tool and to compare different power tools. The actual load may be higher or lower depending on the operating conditions, the condition of the power tool or the accessories. Please allow for breaks and periods when the load is lower for assessment purposes. Arrange protective measures for the user, such as organisational measures based on the adjusted estimates.

Vibration total value (vector sum of three directions) determined in accordance with EN 62841:

$a_{h,D}$	= Vibration emission value (Sawing chip board)
$K_{h,D}$	= Uncertainty (vibration)

Typical A-weighted sound levels:

L_{pA}	= Sound pressure level
L_{WA}	= Acoustic power level
K_{pA}, K_{WA}	= Uncertainty

The noise level can exceed 80 dB(A) during operation.



Wear ear protectors!