



Model TSA-FOT-I

FOLDING OUTFEED TABLE OWNER'S MANUAL



85-008180-00
Rev B - 10202025

TABLE OF CONTENTS

SPECIFICATIONS AND CONFIGURATION OPTIONS	3
UNPACKING	4
ASSEMBLY INSTRUCTIONS	6
INSTALL WITH WING	17
INSTALL WITHOUT WING	26
FOLDING THE OUTFEED TABLE	35
INSTALLING WITH OVERARM DUST COLLECTION	36

Copyright SawStop, LLC
All Rights Reserved

Original Instructions - Folding Outfeed Table

Updates to this manual and additional related documentation such as exploded views and parts lists are available at SawStop.eu or SawStop.uk



www.SawStop.eu/support

EN - Additional translations of this manual are available from the above URL.

IT - Ulteriori traduzioni di questo manuale sono disponibili all'URL sopra indicato.

NL - Bijkomende vertalingen van deze handleiding zijn beschikbaar via de bovenstaande URL.

SV - Ytterligare översättningar av denna bruksanvisning är tillgängliga via ovanstående URL.

FI - Oppaan muita käännöksiä on saatavilla yllä olevasta URL-osoitteesta.

DA - Der kan findes yderligere oversættelser af denne vejledning på ovennævnte webadresse.

NB - Ytterligere oversettelser av denne håndboken er tilgjengelige på ovenstående internetadresse.

PT - Traduções adicionais deste manual estão disponíveis no URL acima.

CS - Další překlady tohoto návodu jsou k dispozici na výše uvedené adrese URL.

PL - Dodatkowe tłumaczenia tej instrukcji dostępne są pod powyższym adresem WWW.

SPECIFICATIONS AND CONFIGURATION OPTIONS

! IMPORTANT:

If you have purchased both the **SawStop Folding Outfeed Table** and a **SawStop Sliding Crosscut Table** (TSA-SA48 or TSA-SA70), install the Sliding Crosscut Table first. Removal of the left extension wing from your saw is one of the configuration options when installing a SawStop Sliding Crosscut Table. Deciding your preferred configuration for the Sliding Crosscut Table will determine whether to follow the **WITH WING** or **WITHOUT WING** assembly instructions in this manual.

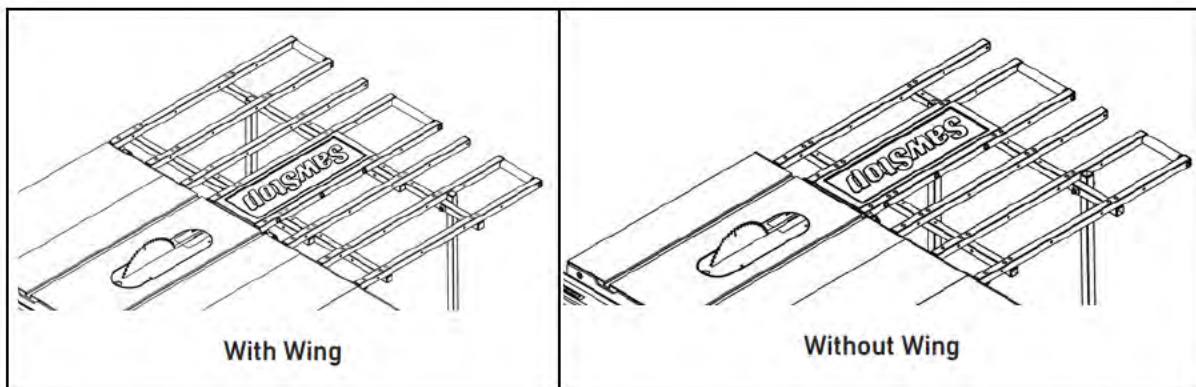

i NOTE:

If installing both the **SawStop Folding Outfeed Table** and the **SawStop Over-Arm Dust Collection** accessory, complete the Folding Outfeed Table installation first. Also, review the relevant instructions on page 36 of this manual.

PRODUCT SPECIFICATIONS

Outfeed Table Dimensions	44 1/4" x 32 1/8" (1124mm x 816mm) With left extension wing INSTALLED 31 3/4" x 32 1/8" (806.5mm x 816mm) With left extension wing REMOVED
Saw and Fence System Compatibility	<ul style="list-style-type: none">Professional Cabinet Saw with T-Glide Advance Fence
Net Weight	37 lbs (16.8kg)
Weight Capacity	250 lbs (113kg)



NOTE:

The letter and number designations for major components and hardware seen below are also referenced on the Hardware Pack and in the assembly instructions that begin on the following page. During assembly, you may find it helpful to refer back to this page.

- A. Table Tube (8)
- B. Table Support Tube (4)
- C. Support Leg (2)
- D. Insert Table (1)
- E. Small Table Roller (2)
- F. Large Table Roller (1)
- G. 5mm Hex Wrench
- H. Table Roller Hardware Pack:
 - 1. M6 x 45 Socket Head Cap Screw (6)
 - 2. M6 x 10 Washer (12)
 - 3. Ball Bearing (6)
 - 4. Table Roller Bushing (6)
 - 5. M6 x 16 Washer (6)
 - 6. M6 Lock Nut (6)
- I. Insert Table Hardware Pack:
 - 1. M6 x 40 Socket Head Cap Screw (6)
 - 2. M6 x 16 Washer (12)
 - 3. M6 Lock Nut (6)
- J. Rear Rail Clamp Hardware Pack:
 - 1. M6 x 20 Socket Head Cap Screw (4)
 - 2. M6 x 35 Socket Head Cap Screw (4)
 - 3. M10 x 20 Set Screw (4)
 - 4. M6 x 16 Washer (36)
 - 5. M6 Lock Nut (8)
 - 6. Clamp Mounting Bracket (4)
- K. Rear Rail Clamp Pack (4):
 - 1. Rear Rail Clamp (1)
- L. Table Tube Hardware Pack:
 - 1. M6 x 35 Socket Head Cap Screw (24)
 - 2. M6 x 16 Washer (24)
 - 3. M6 Lock Nut (24)
- M. Support Leg Hardware Pack (1):
 - 1. M8 x 70 Button Head Socket Screw (2)
 - 2. M8 x 20 Washer (6)
 - 3. M8 x 9 Lock Nut (2)
 - 4. M8 Hex Nut (2)
 - 5. Leveling Foot (2)
- N. Tube End Cap Pack (1):
 - 1. Tube End Cap (26)
- O. Manual

ASSEMBLY INSTRUCTIONS

REQUIRES: Table Roller Hardware Pack (H) 5mm hex wrench
Insert Table Hardware Pack (I) 10mm wrench

The first step in assembling the Folding Outfeed Table is to assemble the three table rollers (E and F) (refer to parts inventory on page 4) and attach two table tubes (A) to each table roller. Referring to the diagram below of one of the table tubes (A), note the solitary hole (U) at the left end. This solitary hole goes nearest the table saw. The sets of paired holes are used to mount the table tubes (A) to the table support tubes (B), and the solitary holes are used to attach the rear rail clamps (K). As you progress through the assembly steps that follow, you may find it helpful to refer back to this diagram.

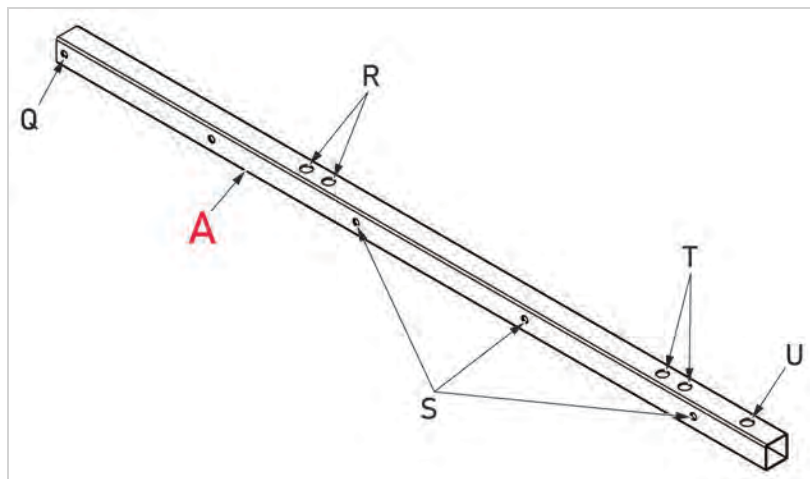

- Q. Table roller mounting hole
- R. Table support tube mounting holes
- S. Insert table mounting holes
- T. Table support tube mounting holes
- U. Rear rail clamp mounting hole

The table support tube mounting holes and clamp mounting holes on the top surfaces of each table tube are larger than the corresponding holes on the bottom surfaces of the table tubes. This allows socket head cap screws to be inserted to secure the table tubes to the table support tubes. Not all of the paired holes are used to mount the table tubes to the table support tubes; different holes are used for different configurations.

There are five solitary holes in both sides of each table tube: the ones furthest from the clamp mounting holes are used to attach a table roller to the table tube, and are not used in every table tube.

The rear three holes on each side of the table tubes are used for mounting the insert table.

1. Place two table tubes (A) on a flat surface, such as a table, with the five larger table support tube mounting holes on the bottom, and the roller mounting holes on the sides.

Insert an M6 x 45 socket head cap screw (H1) through an M6 x 16 washer (I2), then through the roller mounting holes in one of the table tubes (A) (with the head of the socket head cap screw on the side facing away from the other table tube). Next add two M6 x 10 washers (H2), a ball bearing (H3), and an M6 lock nut (H6) onto the cap screws. Use a 5mm hex wrench and a 10mm wrench to tighten the lock nut.

Repeat this process for the other table tube (A). You should now have two table tubes (A) with the larger table support tube mounting holes on the bottom, the heads of the screws (H1) facing away from each other, and the ball bearings (H3) between the table tubes.

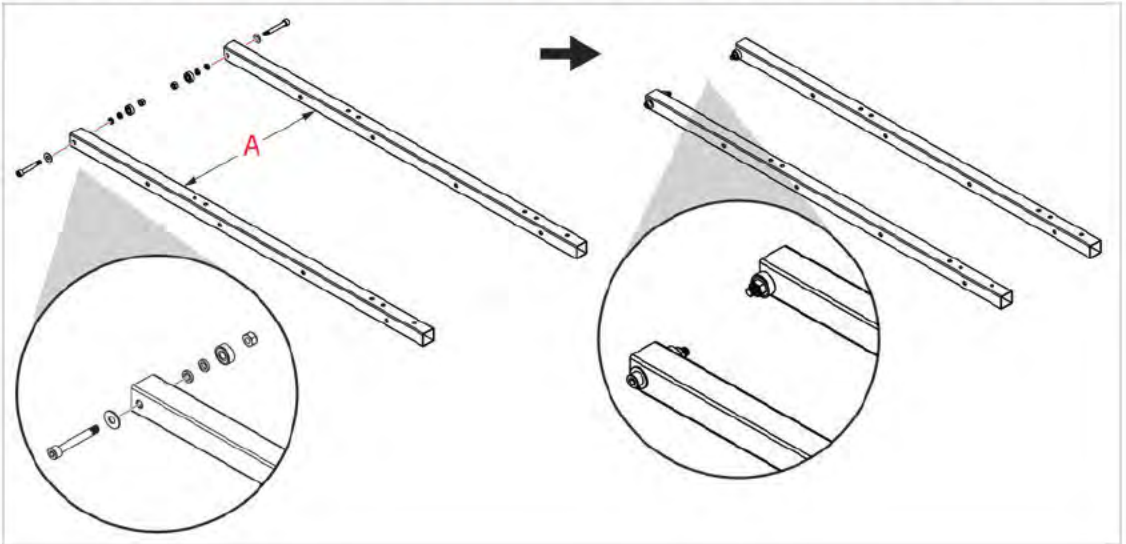

2. Press a table roller bushing (H4) into each end of the large table roller (F), then press the other side of one of the table roller bushings (H4) onto one of the ball bearings (H3) previously attached to a table tube (A). Do not attach the large table roller to the other ball bearing yet.

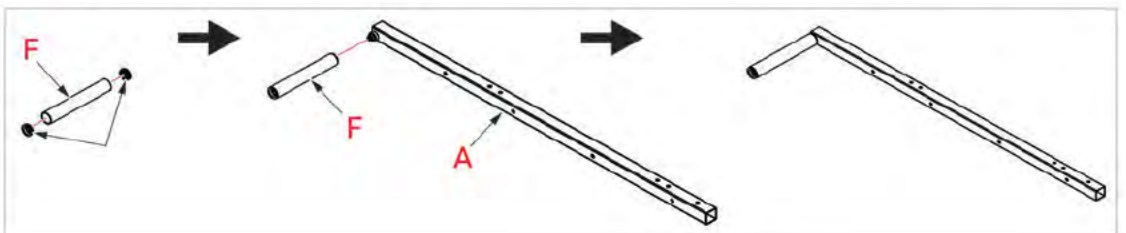

- Place the insert table (D) between the table tubes (A), with the "SawStop" text on the bottom. The three mounting holes in the side of the insert table will align with the three insert table mounting holes in the table tube attached to the large table roller (F).

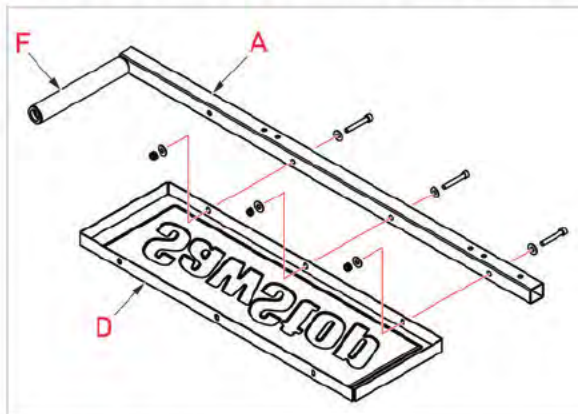

Be careful when positioning the insert table (D) as it is not yet secured to the tubes and could fall or scratch the table tubes. Insert an M6 x 40 socket head cap screw (I1) through an M6 x 16 washer (I2), then through one of the exposed mounting holes in the table tube and insert table. Secure it with a second M6 x 16 washer (I2) and an M6 lock nut on the end of the cap screw. Use a 5mm hex L-wrench and a 10mm wrench to tighten the lock nut (I3).

Repeat this process for the other two exposed mounting holes in the table tube attached to the large table roller and the insert table.

- Slide the second table tube (A) with the other ball bearing (H3) towards the insert table (D) and large table roller (F), and press the ball bearing into the open end of the table roller bushing in the large table roller.

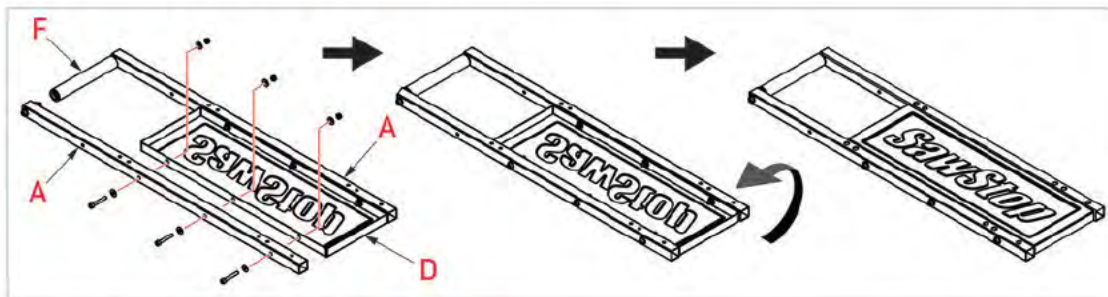

Align the three insert table mounting holes in the table tube (A) with the remaining three mounting holes in the insert table (D). Insert an M6 x 40 socket head cap screw (I1) through an M6 x 16 washer (I2), then through one of the exposed mounting holes in the table tube (A) and insert table (D). Secure it with a second M6 x 16 washer (I2) and an M6 lock nut (I3) to the end of the cap screw. Use a 5mm hex L-wrench and a 10mm wrench to tighten the lock nut.

Repeat this process for the other two exposed mounting holes.

Turn the assembly over, so the large table support tube mounting holes and the "SawStop" text are on top. Use a straight-edge to make sure the top surface of the insert table (D) does not extend above the top surfaces of the table tubes (A). If necessary, loosen the six M6 lock nuts (I3) and adjust the height of the insert table relative to the table tubes, then re-tighten the lock nuts. Set the table tubes with the insert table and large table roller aside.

5. Place two additional table tubes (A) on a flat surface, with the larger table support tube mounting holes on top, and the table roller mounting holes on the sides. Insert an M6 x 45 socket head cap screw (H1) through an M6 x 16 washer (H5), then through the roller mounting holes in one of the table tubes (with the head of the socket head cap screw on the side facing away from the other table tube). Next, add two M6 x 10 washers (H2), a ball bearing (H3), and an M6 lock nut (H6). Use a 5mm hex wrench and a 10mm wrench to tighten the lock nut.

Repeat this process for the other table tube (A).

You should now have two table tubes with the five large table support tube mounting holes on top, with the heads of the screws facing away from each other, and the ball bearings between the table tubes.

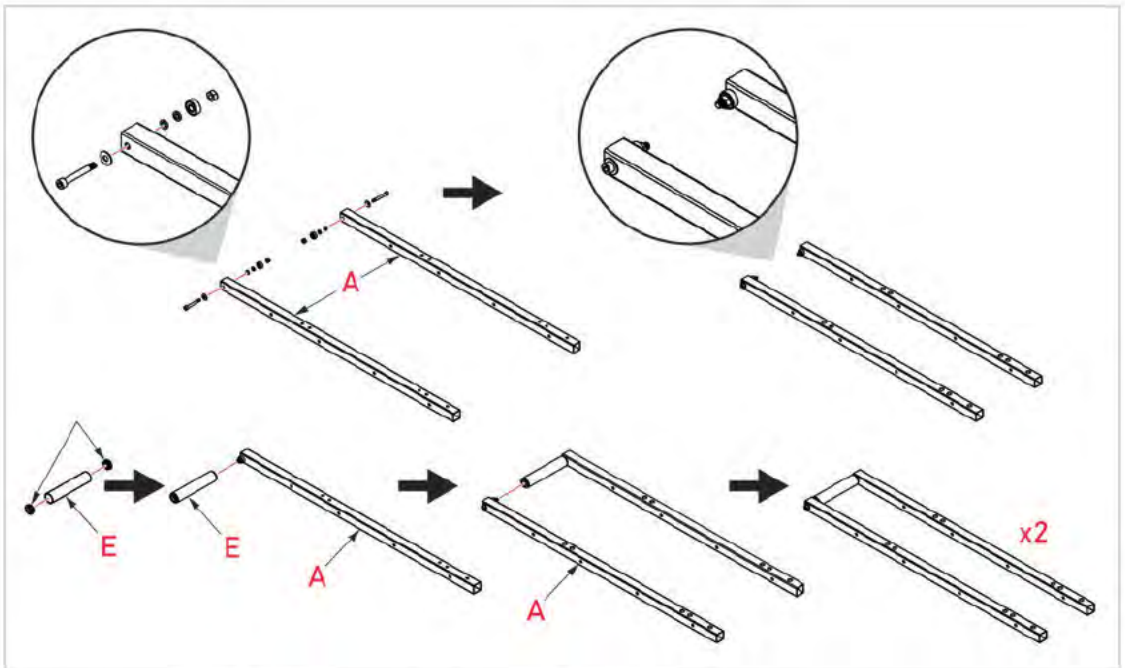

Press a table roller bushing into each end of a small table roller (E), then position it between the two ball bearings you just attached to the two table tubes. Press the ball bearings into the table roller bushings.



WITH WING CONFIGURATION ONLY:

Repeat this process with two additional table tubes (A) and the remaining small table roller (E). Set the table tubes with the small table rollers aside.

! IMPORTANT:

Before continuing, make sure your rip fence is moved all the way to the side or temporarily removed so it does not interfere with the installation of the Folding Outfeed Table.

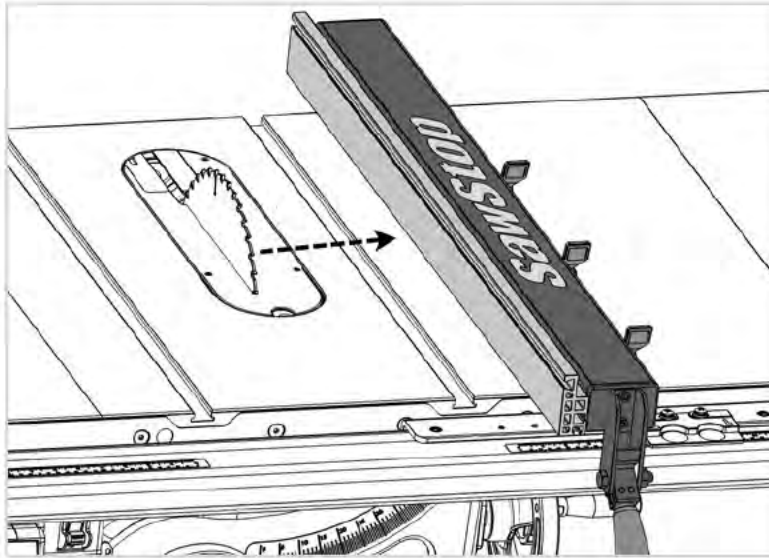

REQUIRES: Rear Rail Clamp Hardware Pack (J) 5mm hex wrench
 Rear Rail Clamp Pack (K) 10mm wrench

- Use a 5mm hex wrench to thread an M10 x 20 set screw (J3) about halfway into the threaded hole in the bottom of a rear rail clamp. The non-hex end of the set screw should extend up toward the top of the clamp, since it will contact the rear rail of the table saw.

Insert an M6 x 35 socket head cap screw (J2) through the hole in the shorter side of a clamp mounting bracket (J6), then through an M6 x 16 washer (J4) and the upper hole in the rear rail clamp. Lastly add a second M6 x 16 washer (J4), and an M6 lock nut (J5) onto the end of the cap screw.

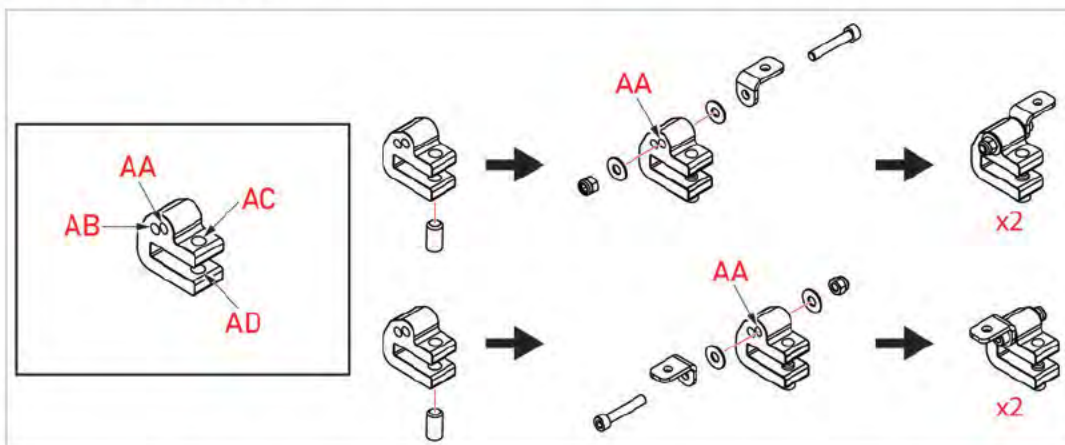

AA. Upper hole AB. Lower hole AC. Hole in top of clamp AD. Hole in bottom of clamp



WITH WING CONFIGURATION ONLY:

Assemble another rear rail clamp exactly as described above.

Assemble two more rear rail clamps, but with the M6 x 1.0 x 35 socket head cap screw (J2) facing the opposite direction, so the clamp mounting bracket (J6) is on the other side of the rear rail clamp (K1). Use a 5mm hex wrench and a 10mm wrench to tighten the lock nuts.



IMPORTANT:

Do not over tighten the lock nuts. The clamp mounting brackets should be able to pivot relative to the rear rail clamps.

7. Position one of the rear rail clamps (K1) next to one of the table tubes (A) attached to the insert table (D), so the opening in the rear rail clamp (the side with the set screw) extends away from the large table roller (F), and the clamp mounting bracket (J6) extends under the table tube. Align the hole in the top of the clamp mounting bracket with the clamp mounting holes in the table tube, so the clamp mounting bracket extends under the table tube, but the rear rail clamp does not.

Insert an M6 x 20 socket head cap screw (J1) down through the large and small clamp mounting holes in the table tube, then through three M6 x 16 washers (J4) and the hole in the top of the clamp mounting bracket (J6). Lastly, add four more M6 x 16 washers (J4), and an M6 lock nut (J5). Use a 5mm hex wrench and a 10mm wrench to tighten the lock nut.

Repeat this process for the table tube attached to the other side of the insert table. The rear rail clamps should extend away from each other.

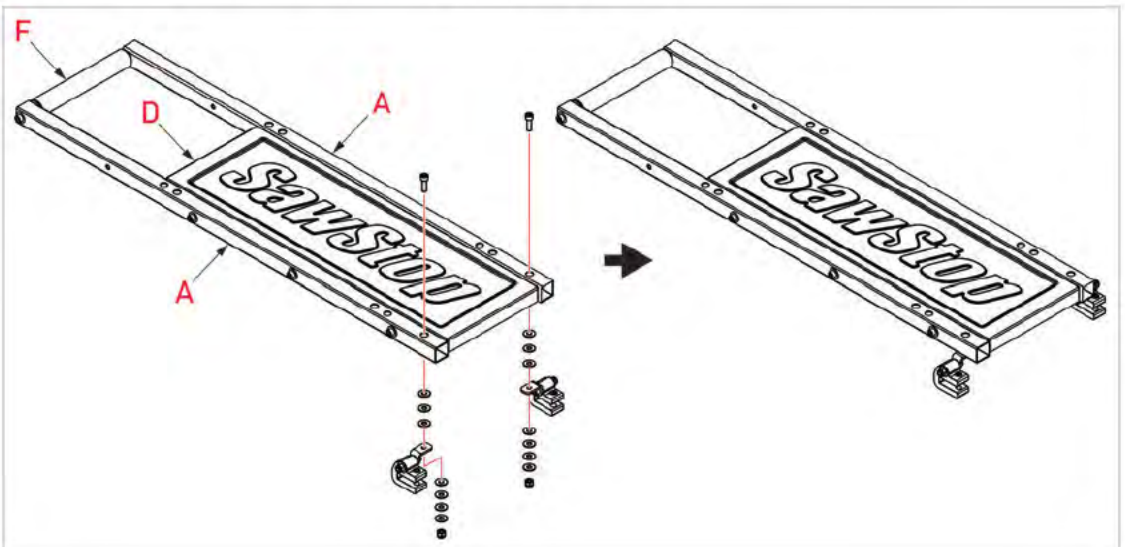

NOTE:

No procedure is needed for the other two rear rail clamp(s)* at this time, as you will need to check (and potentially adjust) the height of the table tubes relative to the table saw.

* WITH WING configuration has two rear rail clamps but WITHOUT WING configuration will just have one.

REQUIRES: Tube End Cap Pack (N) 10mm wrench
5mm hex wrench

8. Install a tube end cap into the open ends of both table tubes attached to the insert table.

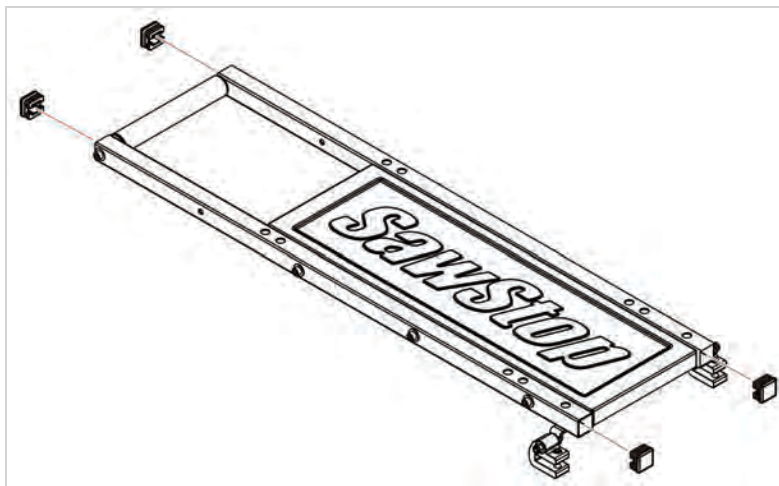

9. Slide the two rear rail clamps (K1) onto the rear rail of the table saw, and use a 5mm hex wrench to tighten the M10 x 20 set screws (J3) against the rear rail.

Pivot the insert table and attached table tubes up until the top surfaces of the insert table and table tubes are parallel with the top of the saw table.

Lay a straight-edge across one of the table tubes so that it extends over the top of the saw table as well. The top surface of the table tube should be flush or just beneath the top of the saw table. The height of the table tubes relative to the saw table can be adjusted by changing the number of M6 washers (J4) above and below the clamp mounting brackets.

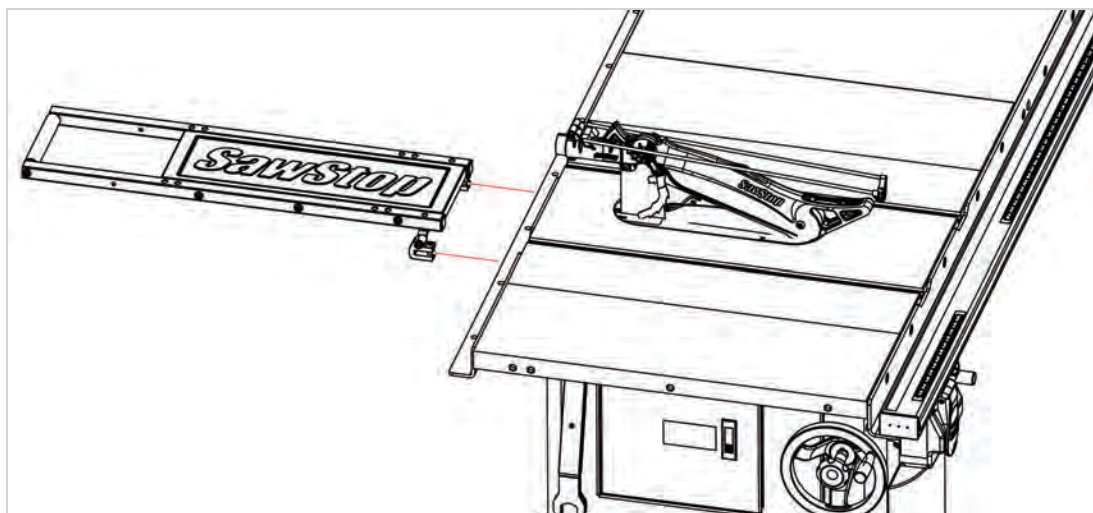

If a table tube extends above the saw table, use a 5mm hex wrench and a 10mm wrench to remove the M6 lock nut (J5) securing the clamp mounting bracket (J6) to the table tube (A). Move one of the washers from above the clamp mounting bracket to below the clamp mounting bracket, then replace the original four washers beneath the clamp mounting bracket and M6 lock nut and tighten the lock nut. Alternatively, if a table tube is too low relative to the saw table, move one of the washers from below the clamp to above the clamp.

Recheck the alignment and move more washers as necessary. Then repeat this adjustment for the clamp on the other side of the insert table. Recheck both table tubes to make sure they are still correct.

Use a 5mm hex wrench to loosen the set screws and remove the rear rail clamps from the rear rail.

Set the assembly aside.

10. Position one of the two remaining rear rail clamps (K1) between one of the sets of table tubes (A) attached to a small table roller (E).



WITH WING CONFIGURATION ONLY:

Position one of the two remaining rear rail clamps (K1) between one of the sets of table tubes (A) attached to a small table roller (E).

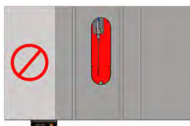

WITHOUT WING CONFIGURATION ONLY:

Position the remaining rear rail clamps (K1) between one of the sets of table tubes (A) attached to a small table roller (E).

Orient the clamp so the rear rail clamp is between the table tubes, the clamp mounting bracket (J6) extends under one of the table tubes (A), and the open end of the clamp extends away from the small table roller.

Align the hole in the top of the clamp mounting bracket (J6) with the clamp mounting holes in the end of the table tube. Insert an M6 x 20 socket head cap screw (J1) down through the clamp mounting holes in the table tube, then through the same number of M6 x 16 washers (J4) you used between the clamp mounting bracket and the table tube with the insert table in the previous step, then through the hole in the clamp mounting bracket (J6) and the same number of M6 washers (J4) you used between the clamp mounting bracket and the lock nut in the previous step. Lastly, secure the washers with an M6 lock nut (J5). Use a 5mm hex wrench and a 10mm wrench to tighten the lock nut.



WITH WING CONFIGURATION ONLY:

Repeat this process with the last rear rail clamp and set of table tubes attached to the remaining small table roller. The two assemblies with the small table rollers should be mirror images of one another. One should have the rear rail clamp on the left table tube (from the user perspective), and the other should have the rear rail clamp on the right table tube (see illustration above).



WITHOUT WING CONFIGURATION ONLY:

Disregard that this sub-assembly is duplicated in the illustration below. Only one is such assembly is required for the without wing configuration.

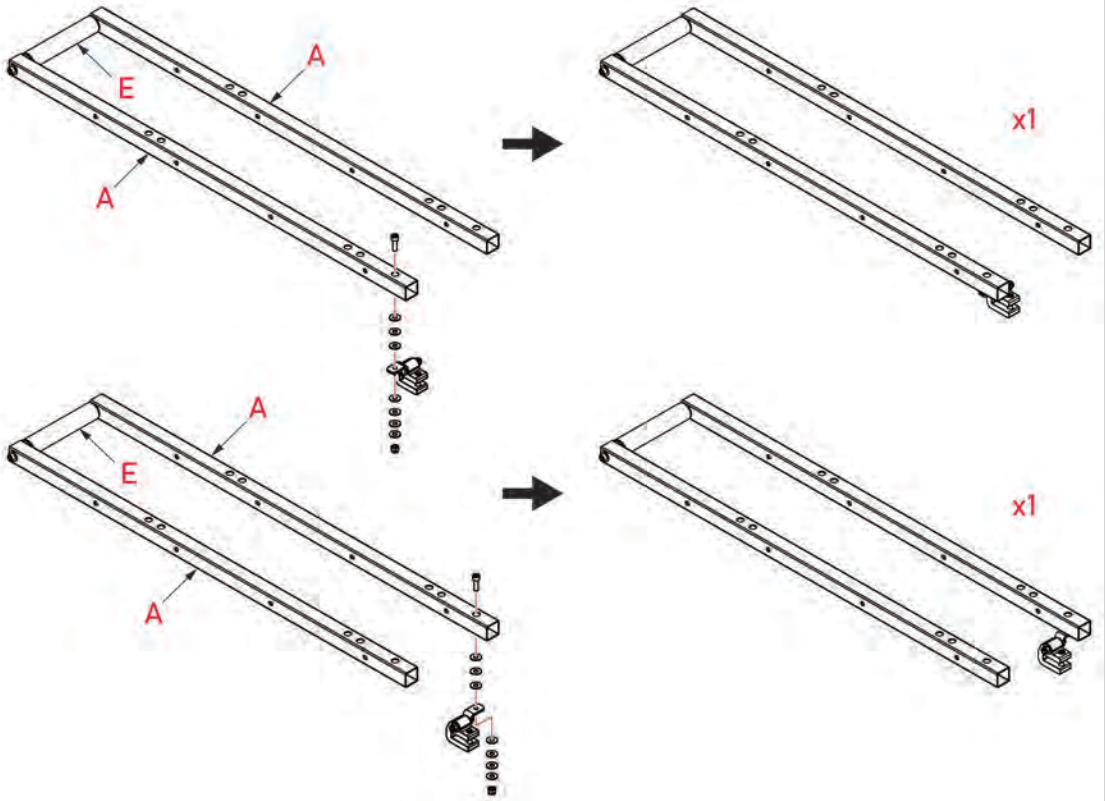

11.



WITH WING CONFIGURATION ONLY:

Install a tube end cap (N1) into the open ends of the four table tubes (A) attached to the two small table rollers (E) and into the open ends of the remaining two solitary table tubes (not attached to table rollers).



WITHOUT WING CONFIGURATION ONLY:

Install a tube end cap into the open ends of the two table tubes (A) attached to the small table roller (E) and into the open ends of two solitary table tubes (not attached to table rollers).

Additional end caps, will be installed later.

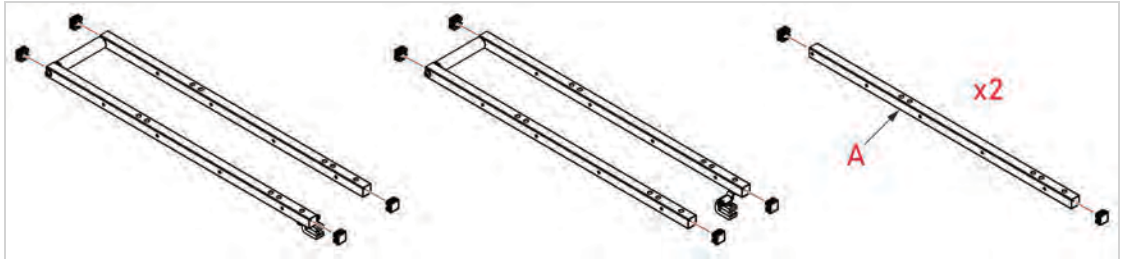

WITH WING CONFIGURATION ONLY:

Proceed with step 12 on page 17.



WITHOUT WING CONFIGURATION ONLY:

Proceed with step 12 on page 26.

INSTALL WITH WING



After completing common steps (1-11), proceed with the instructions below to finish installation of your folding outfeed table if your chosen configuration leaves the left extension wing installed on your saw. You can find more information about this on page 3.

12. Place the four table support tubes (B) on the floor behind your table saw and align them as shown. In order to align the table support tubes, place two tubes next to each other, with the ten table tube mounting holes on the top and bottom and the two support leg mounting holes on the sides.

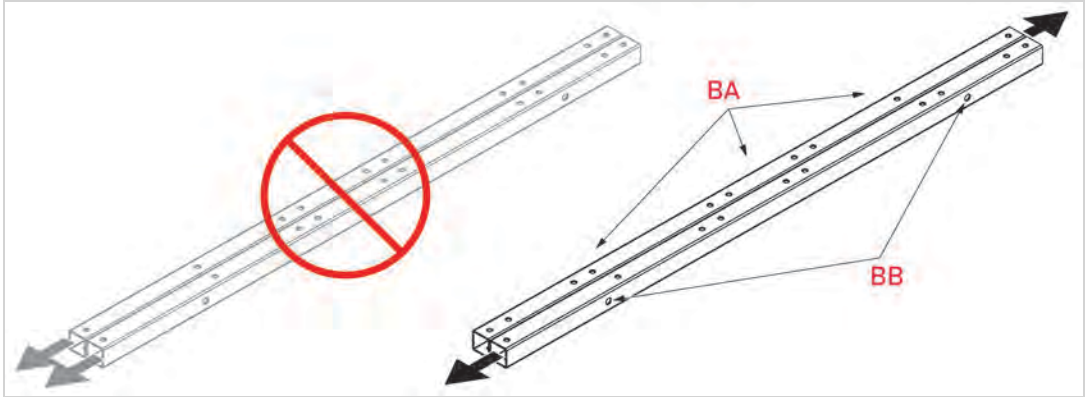

BA. Table tube mounting holes

BB. Support leg mounting holes

If all the mounting holes align, turn one of the tubes 180 degrees, so only the mounting holes at the ends line up. Then slide the table support tubes relative to one another until the non-overlapping portions of each tube have three mounting holes, and four mounting holes on each tube overlap, as indicated by the red circles below.

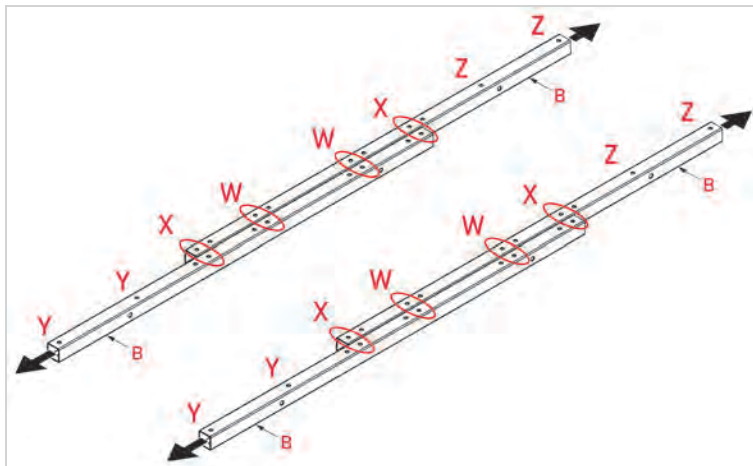

Once the mounting holes are aligned, position the two table support tubes so the one extending toward the right of the table saw (from the user perspective) is further away from the table saw than the table support tube extending toward the left of the table saw.

Repeat this process for the other two table support tubes.

REQUIRES: Table Tube Hardware Pack (L)	10mm wrench
5mm hex wrench	

13. Position the two table tubes (A) attached to the insert table (D) across the four table support tubes (B), in the middle of the overlapping sections of the table support tubes, with the insert table and rear rail clamps on the end closest to the table saw.

Align the mounting holes in the table tubes with the two sets of aligned holes in the center of the overlapping sections of the table support tubes (marked as holes "W" in the illustration on the next page). Insert an M6 x 35 socket head cap screw (L1) through one of the exposed mounting holes in one of the table tubes (A) and table support tubes (B). Secure the socket head cap screw with an M6 x 16 washer (L2) and an M6 lock nut (L3). Do not tighten the lock nut at this time.

Repeat this process for the remaining seven table support tube mounting holes in the table tubes attached to the insert table.

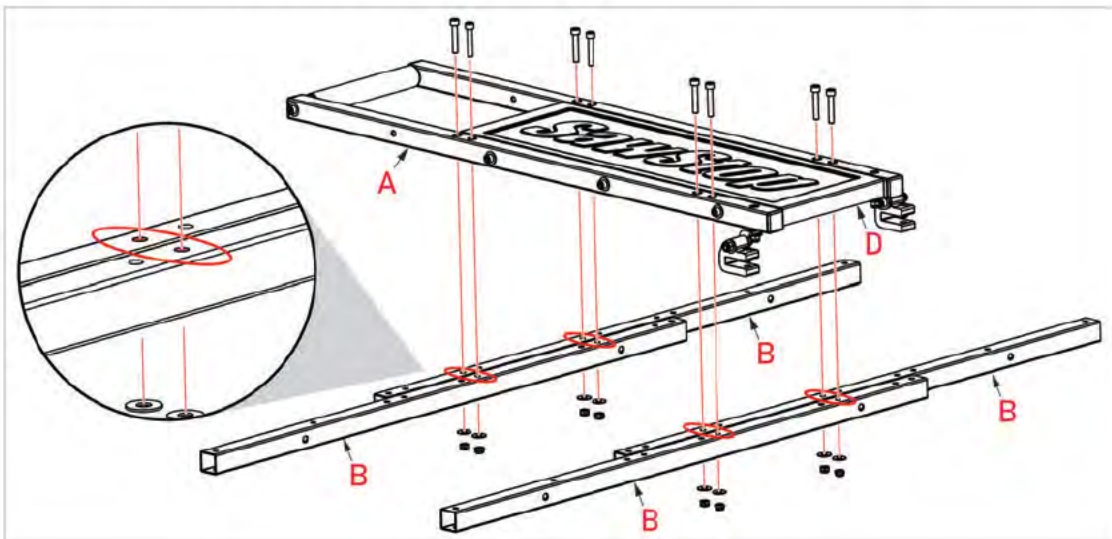

! IMPORTANT:

Use the correct mounting holes in the table support tubes. Check carefully to make sure the insert table and attached table tubes are aligned correctly. There should be one set of aligned holes and five non-aligned holes to the left of the table tubes, two non-aligned holes between the table tubes, and one set of aligned holes and five non-aligned holes to the right of the table tubes.

REQUIRES: Support Leg Hardware Pack (M)	13mm wrench
5mm hex wrench	10mm wrench

14. Locate the two support legs (C) and remove the two leveling feet (M5) from the Support Leg Hardware Bag along with the two M8 hex nuts (M4). Thread an M8 hex nut onto the threaded shaft of each foot so that the nut is close to the rubber base, and then thread the foot into the bottom of a support leg.

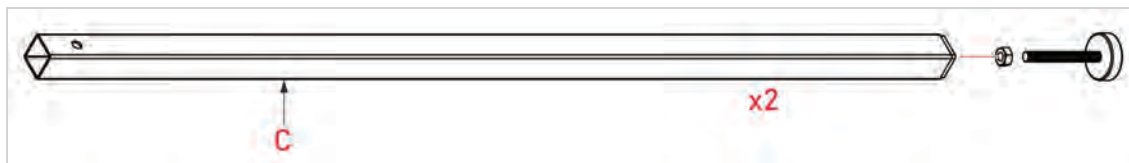

15. Place one support leg (C) between the two sets of table support tubes (B), with the open end of the support leg on the left and the leveling foot (M5) extending toward the right (from the user perspective).

Align the mounting hole in the top of the support leg (C) with the support leg mounting hole in the table support tube (B). Insert an M8 x 70 button head socket screw (M1) through an M8 x 20 washer (M2), then through the exposed mounting holes in the support leg, another M8 x 20 washer (M2), the exposed mounting holes in the table support tube, another M8 x 20 washer (M2), and an M8 lock nut (M3).

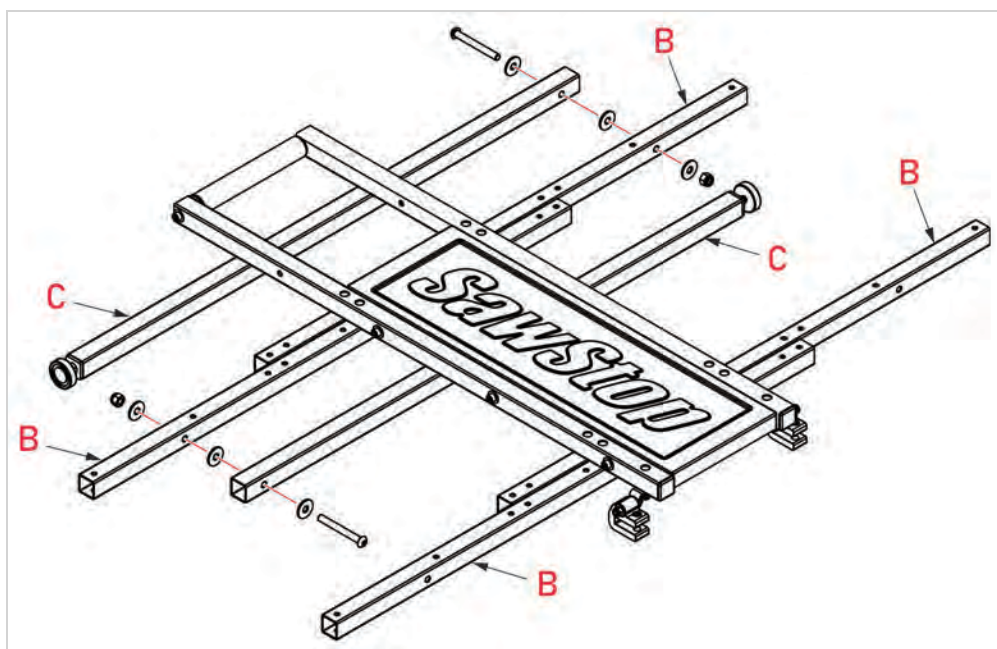

Use a 5mm hex wrench on the socket screw and a 13mm wrench on the lock nut to tighten the nut until the support leg (C) can pivot, but still moves with some resistance.

Repeat the process with the other support leg, but place the remaining support leg on the other side of the table support tubes (further from the table saw), with the open end of the support leg on the right and the leveling foot extending toward the left.

16. Slide the rear rail clamps (K1) attached to the table tubes (A) with the insert table onto the rear rail of your table saw, keeping the insert table between the miter gauge slots in your saw table. Use a 5mm hex wrench to thread the set screws into the clamps enough so they engage the rear rail, but do not tighten them. They need to remain loose so you can align the outfeed table to the table saw.

Pivot the support legs down so the leveling feet contact the ground.

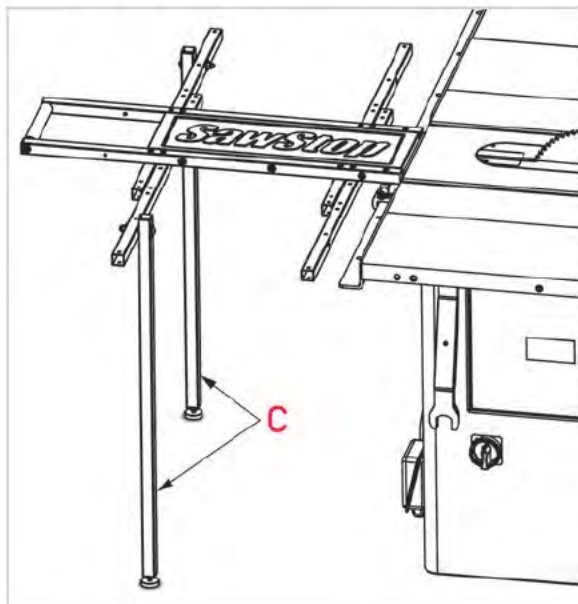

17. Position a solitary table tube (A) (not attached to a table roller) across the four table support tubes (B), with the clamp mounting holes on the end closest to the table saw. Align the mounting holes in the table tube with the set of aligned mounting holes in the table support tubes just to the side of the table tubes attached to the insert table (D) (marked as holes "X" on the second illustration in step 12).

Position the other solitary table tube (A) on the other side of the insert table, and align the mounting holes in the table tube with the set of aligned mounting holes in the table support tubes (B) just to the other side of the table tubes attached to the insert table (marked as holes "X" on the second illustration in step 12).

Insert an M6 x 35 socket head cap screw (L1) through one of the exposed mounting holes in a table tube (A) and table support tube (B), then through an M6 x 16 washer (L2) and an M6 lock nut (L3). Do not tighten the lock nut at this time.

Repeat this process for the remaining seven sets of mounting holes in the two solitary table tubes and table support tubes.

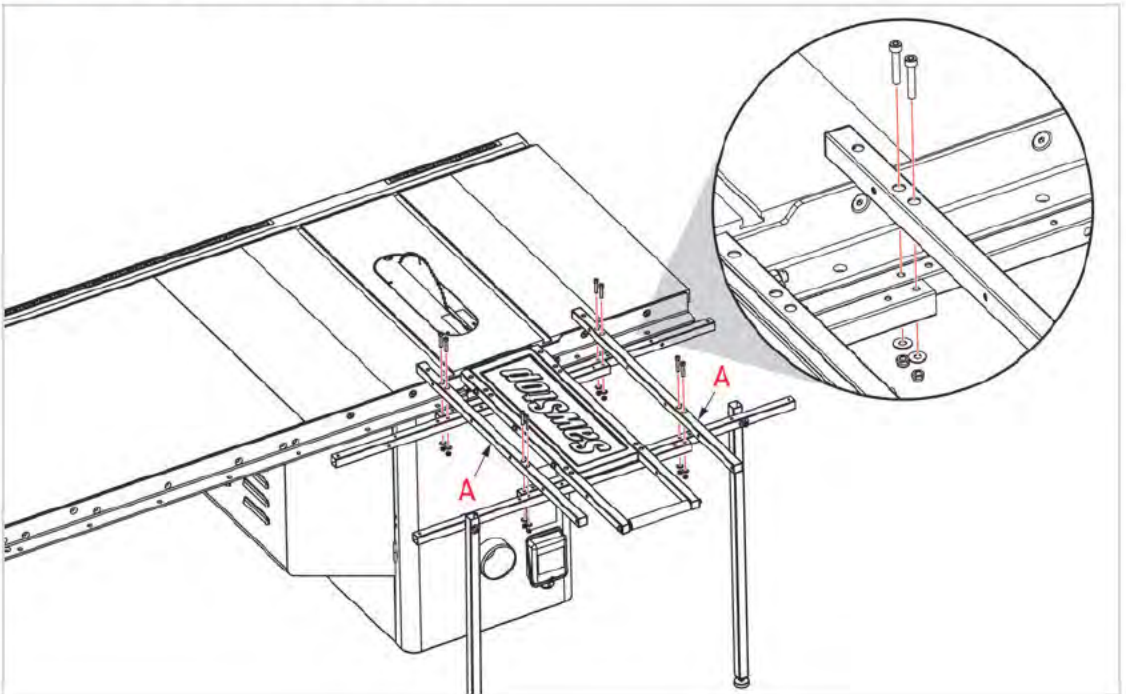

18. Position the set of table tubes with the smaller table roller (E) and the rear rail clamp on the left table tube at the left end of the table support tubes. The rear rail clamp should be on the table tube furthest from the insert table. If it is not, place the table tubes with the small table roller aside and replace them with the other set of table tubes with the other small table roller.

Slide the rear rail clamp onto the rear rail of your table saw, but do not tighten the set screw. Align the mounting holes in the table tubes with the mounting holes at the left end of the table support tubes (marked as holes "Y" on the second illustration in step 12), making sure that tube end caps are almost flush with the rear rail.

There are two sets of two holes paired together in the top and bottom of each table tube; you will use the hole in each pair that is closer to the table saw.

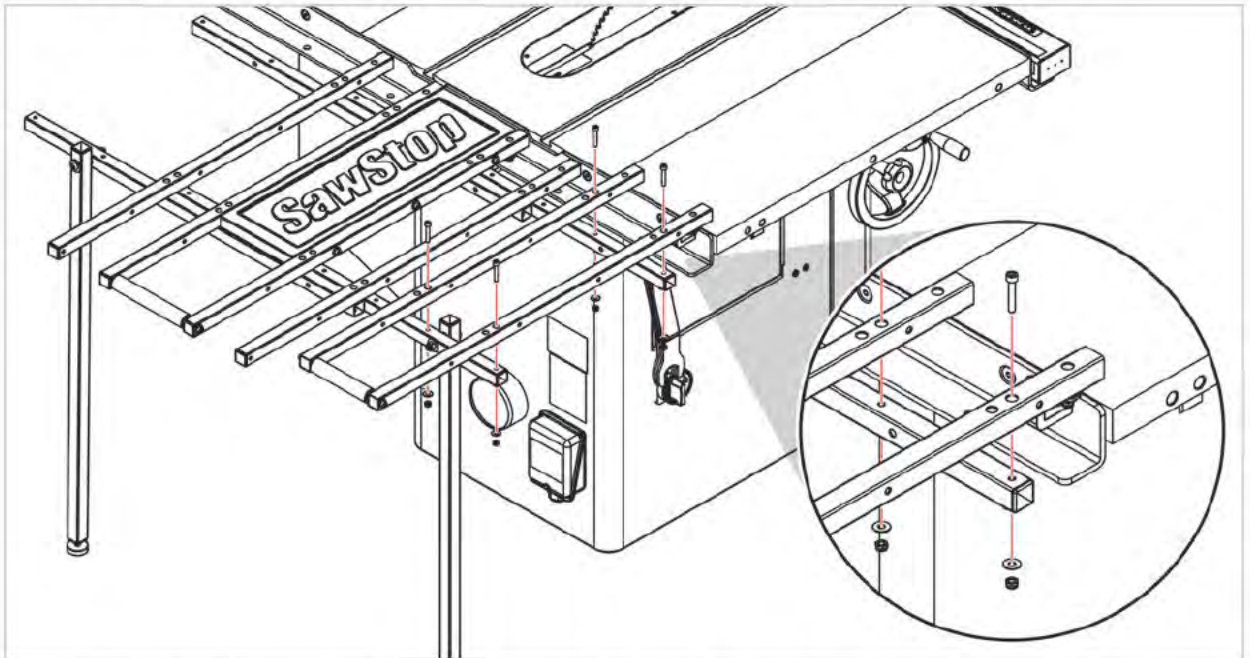

Insert an M6 x 35 socket head cap screw (L1) through one of the exposed mounting holes in a table tube (A) and table support tube (B), then through an M6 x 16 washer (L2) and an M6 lock nut (L3). Do not tighten the lock nut at this time.

Repeat this process for the remaining three sets of mounting holes in the two table tubes and table support tubes.

- Slide the Folding Outfeed Table toward the left end of the rear rail on the table saw (from the user perspective), until the edge of a table support tube is flush with the end of the rear rail. If necessary, use a 5mm hex wrench to loosen the M10 x 20 set screws (J3) on the rear rail clamps near the insert table.

Check to make sure the M10 x 20 set screws (J3) in the rear rail clamps do not interfere with any of the holes in the rear rail. If a set screw interferes with a hole, you can switch the rear rail clamp to a different table tube. Additionally, you can disassemble the clamp and reassemble it with the clamp mounting bracket on the other side, which will allow you to switch the clamp to the other side of the table tube.

NOTE:

Depending on your saw model, the left side of the outfeed table may not be flush with the left side of the extension wing.

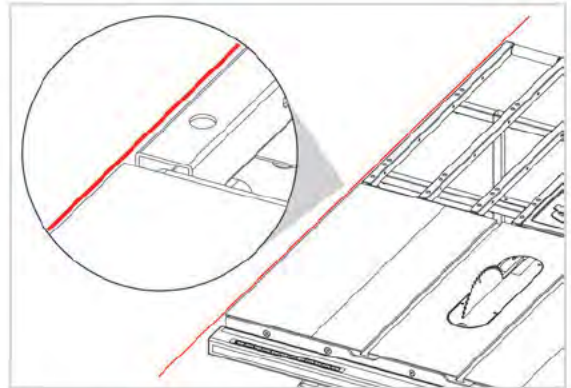

- Use a 5mm hex wrench to tighten the three M10 x 20 set screws (J3) to secure the Folding Outfeed Table to the rear rail. Use a straightedge to recheck that the tops of the table tubes are flush or just beneath the top of the saw table and make any necessary adjustments.

21. Position the remaining set of table tubes (A) at the right end of the table support tubes (B), and slide the rear rail clamp (K1) onto the rear rail of the table saw. Align the mounting holes in the table tubes with the mounting holes at the right end of the table support tubes (marked as holes "Z" on the second illustration in step 12), making sure that the ends of the table tubes are almost flush with the rear rail of the table saw.

There are two sets of holes paired together in the top and bottom of each table tube; you will use the hole in each pair that is further from the table saw.

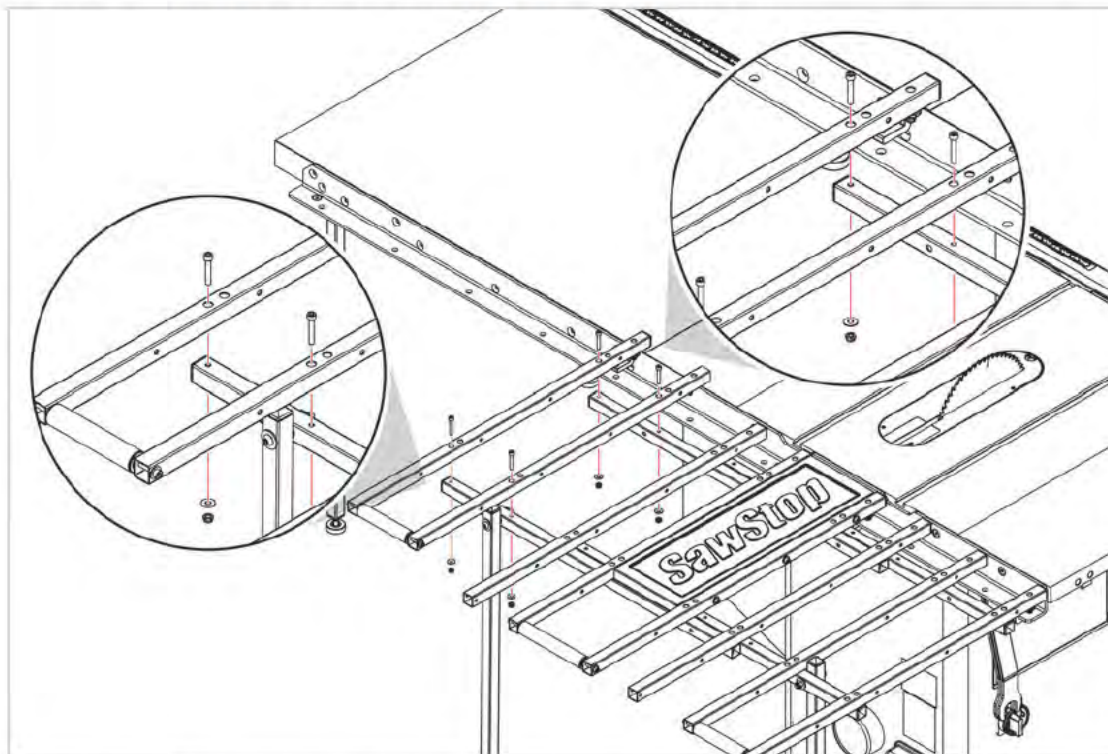

Insert an M6 x 35 socket head cap screw (L1) through one of the exposed mounting holes in a table tube (A) and table support tube (B), then through an M6 x 16 washer (L2) and an M6 lock nut (L3). Do not tighten the lock nut at this time.

Repeat this process for the remaining three sets of mounting holes in the two table tubes and table support tubes. Use a 5mm hex wrench to tighten the M10 x 20 set screw (J3) to secure the rear rail clamp.

22. Press a tube end cap (N1) into the top of both support legs (C) and into the ends of the four table support tubes (B).

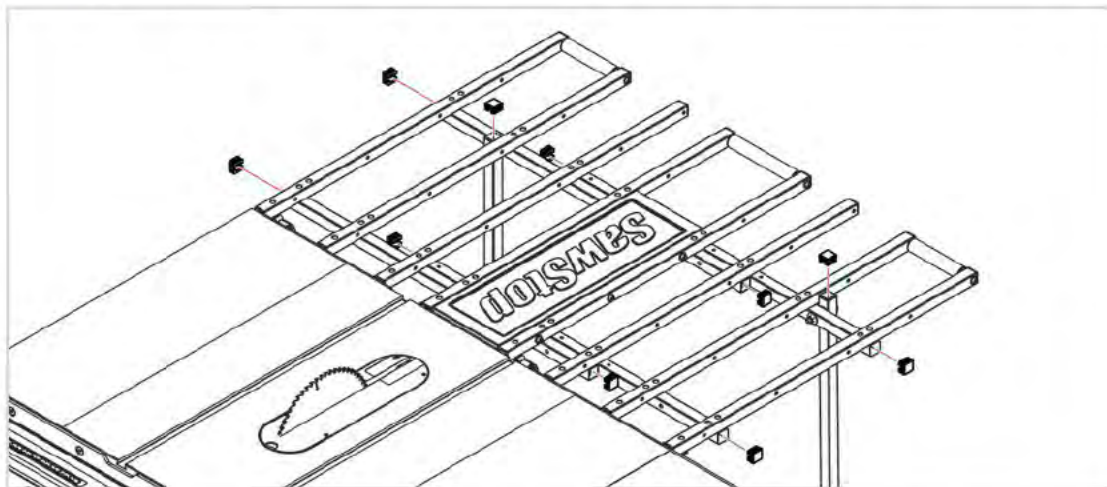

23. Use a 5mm hex wrench and a 10mm wrench to tighten the 24 socket head cap screws and lock nuts securing the table tubes to the table support tubes.

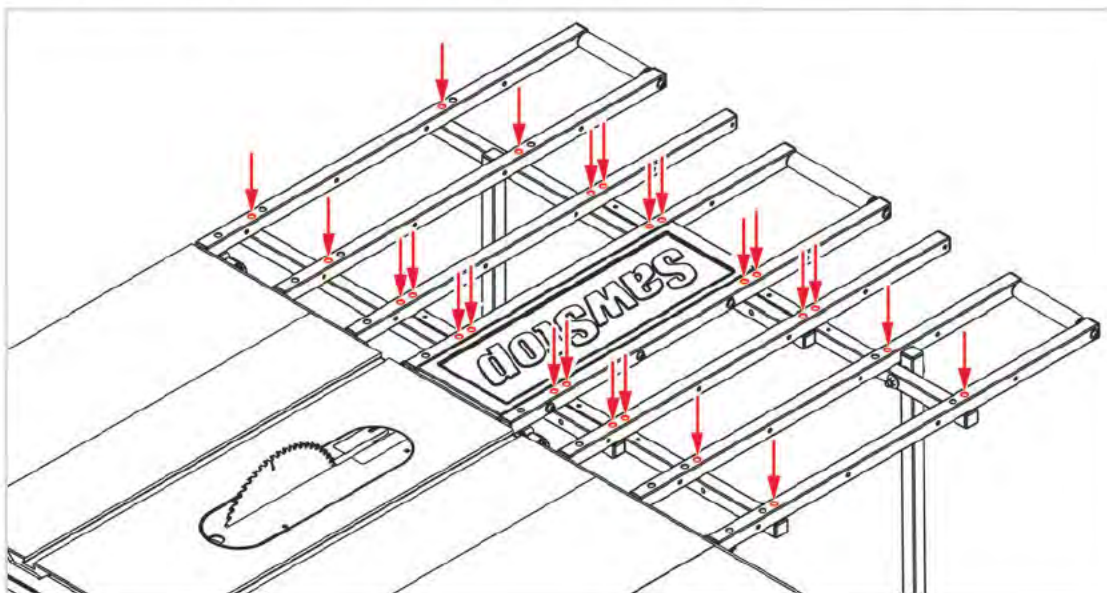

Congratulations! Assembly of your Folding Outfeed Table is complete.

Skip to page 35 for further instructions.

INSTALL WITHOUT WING



After completing common steps (1-11), proceed with the instructions below to finish installation of your folding outfeed table if your chosen configuration requires the left extension wing removed from your saw. You can find more information about this on page 3.

12. Place two table support tubes (B) on the floor behind your table saw and align them as shown below. The four sets of paired together holes should be on the left (from the user perspective), and the two solitary holes should be on the right.

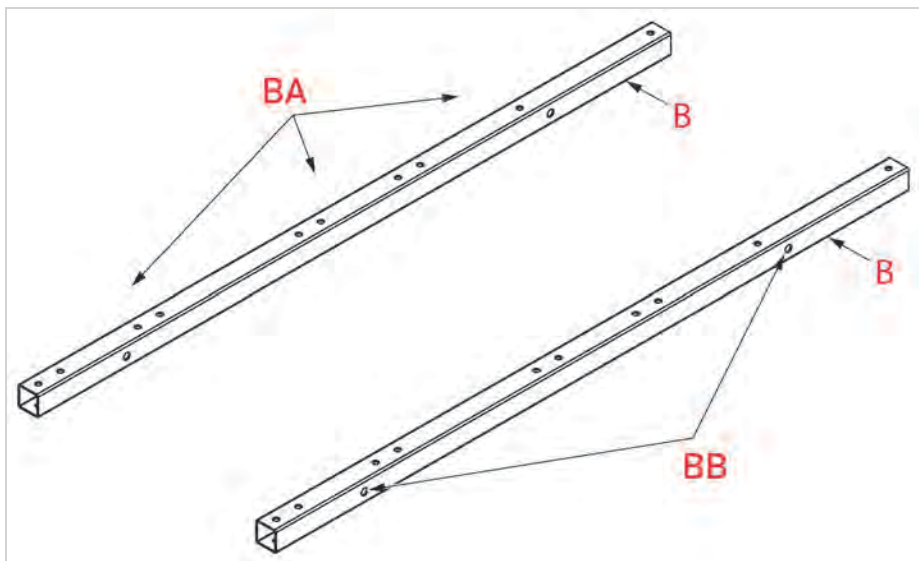

BA. Table tube mounting holes BB. Support leg mounting holes

REQUIRES: Table Tube Hardware Pack (L)

13. Position the two table tubes (A) attached to the insert table (D) across the two table support tubes (B), with the insert table and rear rail clamps on the end closest to the table saw.

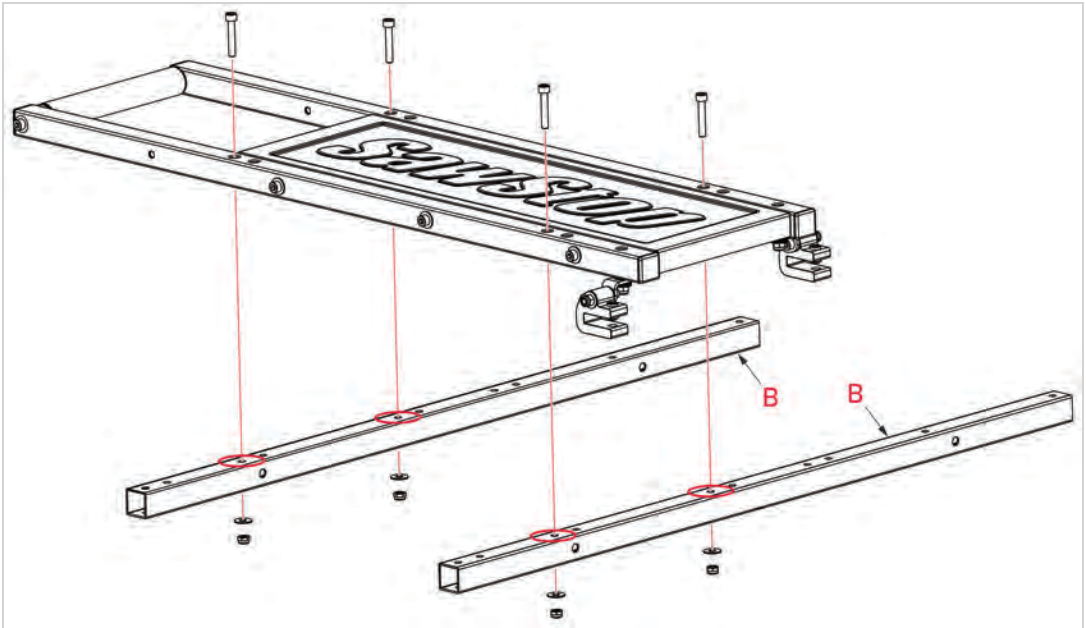

Align the mounting holes in the table tubes with the holes marked as "X" in the illustration below.

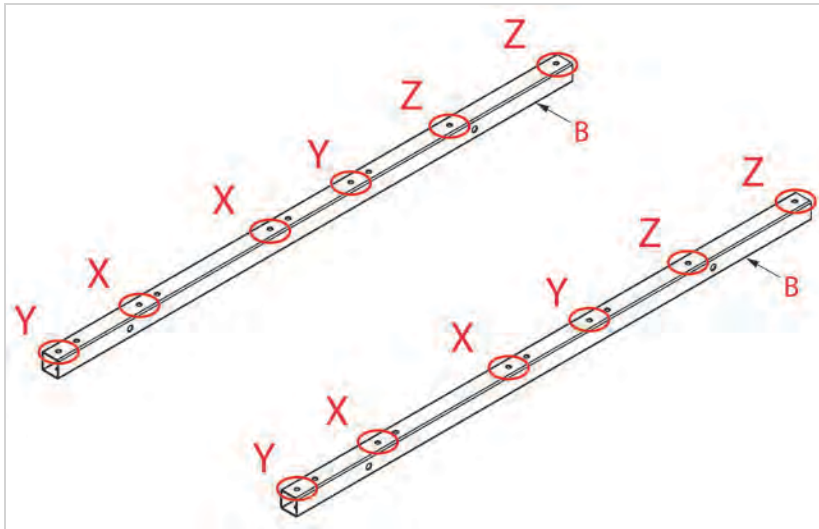

Insert an M6 x 35 socket head cap screw (L1) through one of the exposed mounting holes in one of the table tubes and table support tubes (A). Secure the socket head cap screw with an M6 x 16 washer (L2) and an M6 lock nut (L3). Do not tighten the lock nut at this time.

Repeat this process for the remaining three table support tube mounting holes in the table tubes attached to the insert table.



IMPORTANT:

It is very important to use the correct mounting holes in the table support tubes. Check carefully to make sure the insert table and attached table tubes are aligned correctly. There should be two holes to the left of the insert table, one hole between the table tubes, and five holes to the right of the insert table.

REQUIRES:	Support Leg Hardware Pack (M)	13mm wrench
	5mm hex wrench	10mm wrench

14. Locate the two support legs (C) and remove the two leveling feet (M5) from the Support Leg Hardware Bag (M) along with the two M8 hex nuts (M4). Thread an M8 hex nut onto the threaded shaft of each foot so that the nut is close to the rubber base, and then thread the foot (M5) into the bottom of a support leg (C).

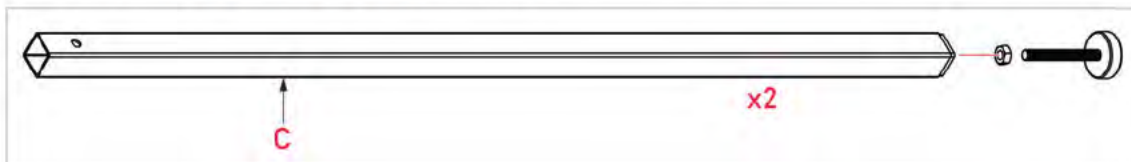

- Place one support leg (C) between the two sets of table support tubes (B), with the open end of the support leg on the left and the leveling foot (M5) extending toward the right (from the user perspective).

Align the mounting hole in the top of the support leg (C) with the support leg mounting hole in the table support tube (B). Insert an M8 x 70 button head socket screw (M1) through an M8 x 20 washer (M2), then through the exposed mounting holes in the support leg, another M8 x 20 washer (M2), the exposed mounting holes in the table support tube, another M8 x 20 washer (M2), and an M8 lock nut (M3).

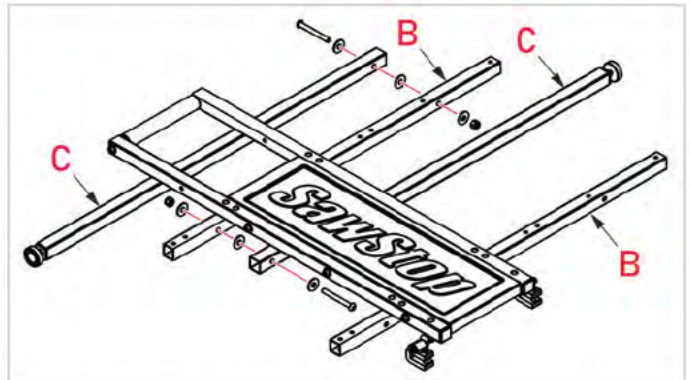
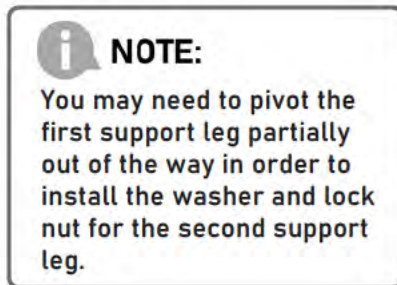

Use a 5mm hex wrench on the socket screw and a 13mm wrench on the lock nut to tighten the nut until the support leg (C) can pivot, but still moves with some resistance.

Repeat the process with the other support leg, but place the remaining support leg on the other side of the table support tubes (further from the table saw), with the open end of the support leg on the right and the leveling foot extending toward the left.

- Slide the rear rail clamps (K1) attached to the table tubes (A) with the insert table onto the rear rail of your table saw, keeping the insert table between the miter gauge slots in your saw table. Use a 5mm hex wrench to thread the set screws into the clamps enough so they engage the rear rail, but do not tighten them. They need to remain loose so you can align the outfeed table to the table saw.

Pivot the support legs down so the leveling feet contact the ground.

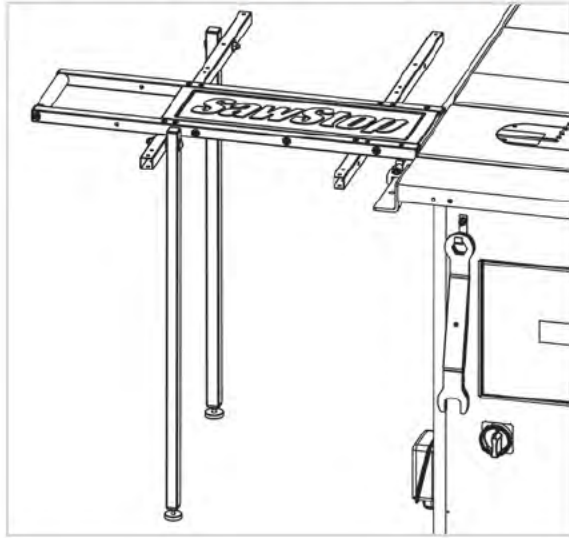

17. Position a solitary table tube (A) (not attached to a table roller) across the two table support tubes (B), with the clamp mounting holes on the end closest to the table saw. Align the mounting holes in the table tube with holes labeled as "Y" on the illustration above in step 13).

Position the other solitary table tube (A) on the other side of the insert table (D), and align the mounting holes in the table tube with the holes marked as "Y" on the second illustration in step 13.

Insert an M6 x 35 socket head cap screw (L1) through one of the exposed mounting holes in a table tube (A) and table support tube (B), then through an M6 x 16 washer (L2) and an M6 lock nut (L3). Do not tighten the lock nut at this time.

Repeat this process for the remaining three sets of mounting holes in the two solitary table tubes and table support tubes.

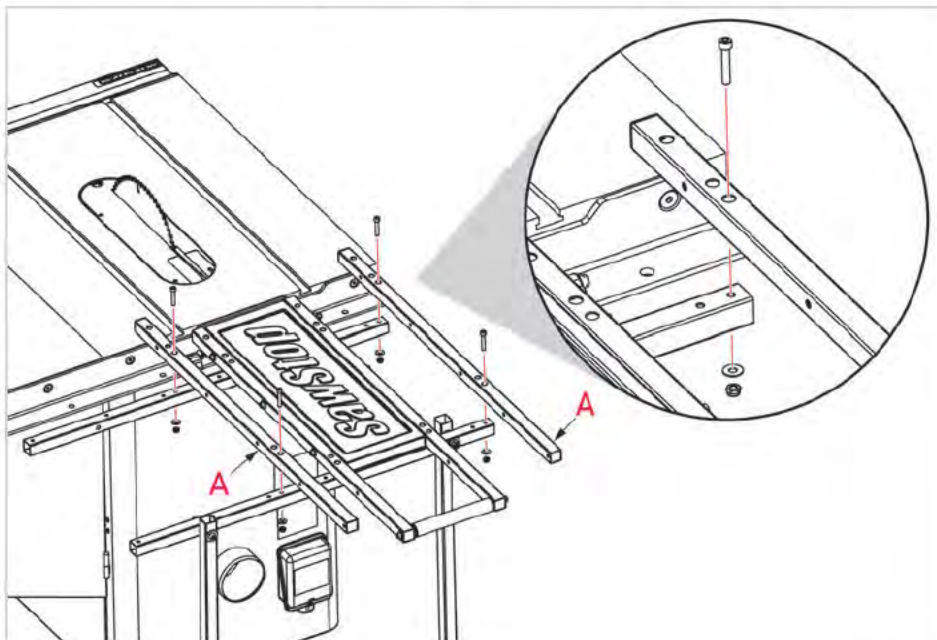

18. Position the set of table tubes with the small table roller (E) at the right end of the table support tubes. The rear rail clamp should be on the table tube furthest from the insert table. If it is not, remove it and switch it to the table tube furthest from the insert table.

Slide the rear rail clamp (K1) onto the rear rail of your table saw, but do not tighten the set screw. Align the mounting holes in the table tubes (A) with the mounting holes at the left end of the table support tubes marked as holes "Z" in on the illustration above in step 13. Make sure that tube end caps are almost flush with the rear rail. There are two sets of two holes paired together in the top and bottom of each table tube; you will use the hole in each pair that is further from the table saw.

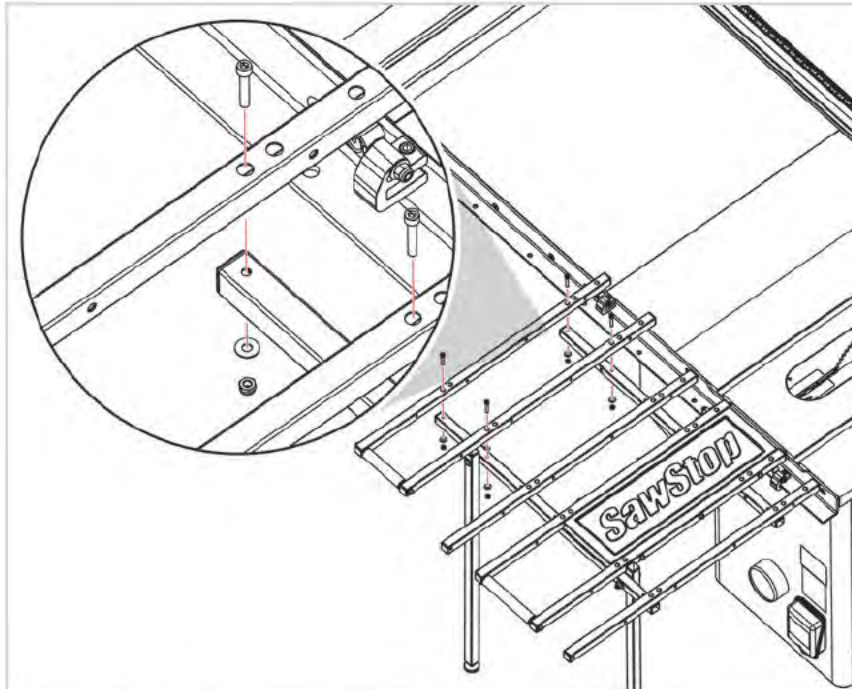

Repeat this process for the remaining three sets of mounting holes in the two table tubes and table support tubes.

19. Slide the Folding Outfeed Table toward the left end of the rear rail on the table saw (from the user perspective), until the table tubes attached to the insert table clear the miter slots.

If necessary, use a 5mm hex wrench to loosen the M10 x 20 set screws (J3) on the rear rail clamps (K1) near the insert table. Check to make sure the M10 set screws in the rear rail clamps do not interfere with any of the holes in the rear rail.

If a set screw interferes with a hole, you can switch the rear rail clamp to a different table tube. Additionally, you can disassemble the clamp and reassemble it with the clamp mounting bracket on the other side, which will allow you to switch the clamp to the other side of the table tube.

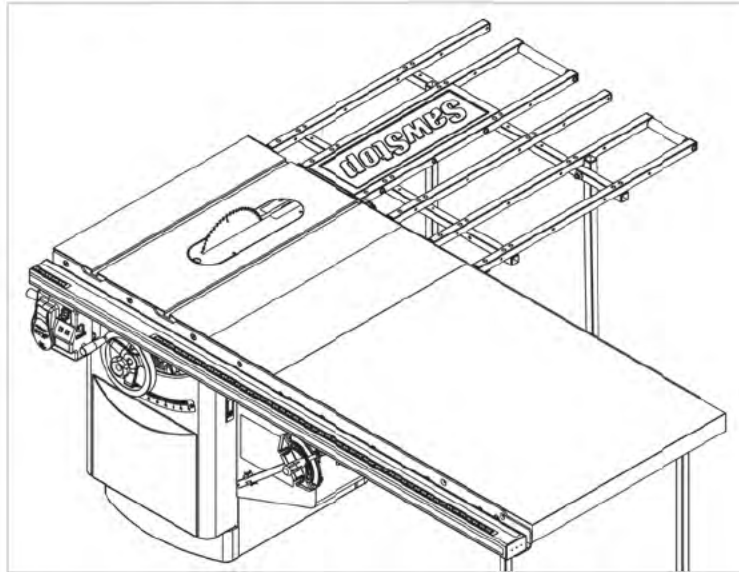

20. Use a 5mm hex wrench to tighten the three M10 x 20 set screws (J3) to secure the Folding Outfeed Table to the rear rail. Use a straightedge to recheck that the tops of the table tubes are flush or just beneath the top of the saw table and make any necessary adjustments.

21. Press a tube end cap into the top of both support legs and into the outer ends of the four table support tubes.

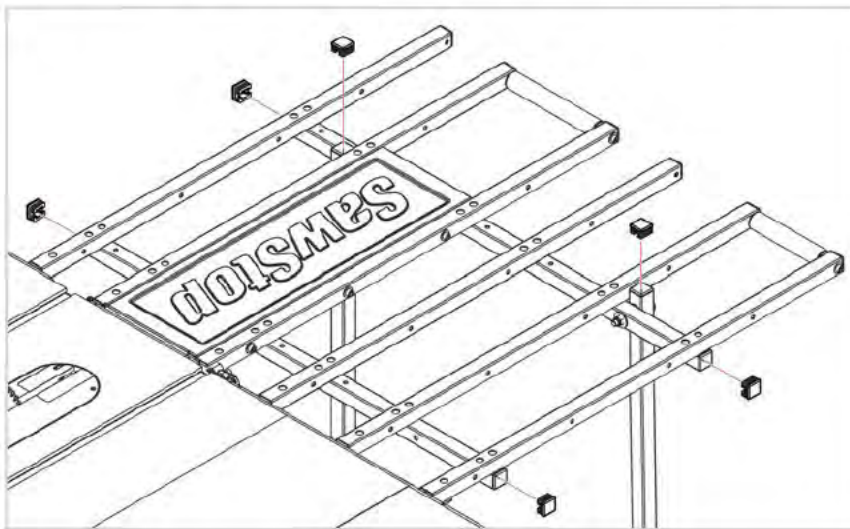

22. Use a 5mm hex wrench and a 10mm wrench to tighten the 12 socket head cap screws and lock nuts securing the table tubes to the table support tubes.

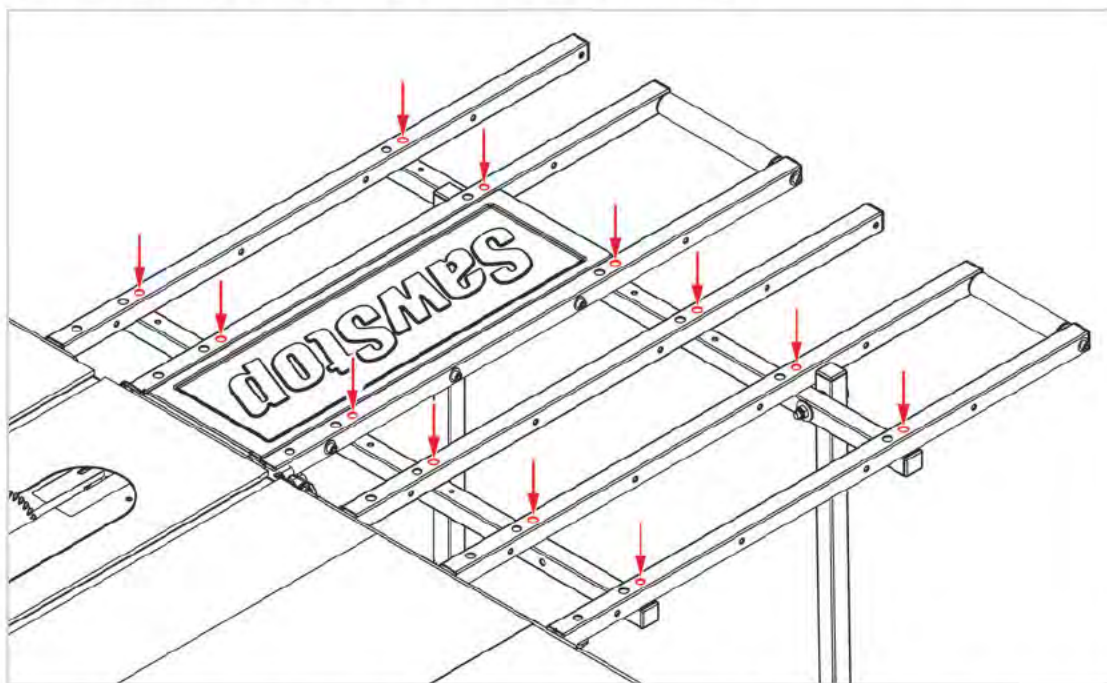

Congratulations! Assembly of your Folding Outfeed Table is complete.

FOLDING THE OUTFEED TABLE

To store your saw with the smallest footprint possible, position your outfeed table in its folded position. To do this, pivot the support legs to fold inward under the table and lower the table down into its folded resting position.

To reset your Folding Outfeed Table to its functioning position, be sure to first move and secure your saw in your desired location, raise the Folding Outfeed Table to the saw table height, and pivot both of the support legs down so that the leveling feet rest on the ground.

To adjust the height of the Folding Outfeed Table, screw the leveling feet in or out of the support legs as needed and secure them into position by screwing the hex nut snug against the bottom of the support leg.



NOTE:

The table does not stow completely against the saw cabinet if the SawStop Industrial Mobile base is installed. Be mindful near the saw of this potential trip hazard.

INSTALLING WITH OVERARM DUST COLLECTION

On any Professional Cabinet Saw using a 36" (910mm) fence rail system, the Folding Outfeed Table and the TSA-ODC Overarm Dust Collection system are both mounted on the rear rail. For both to mount on the rail as required, while allowing for folding of the TSA-FOT, you must either:

1. Cut the lower Overarm Dust Collection Tube (Procedure listed below) - or -
2. Shift the Overarm Dust Collection to the right, extending it 12" (305mm) past the end of your extension table (Procedure listed on the next page).

To cut the lower TSA-ODC tube:

Measure 12" (305mm) from the end of the lower tube (see arrow in the illustration below), mark the measurement. Cut the tube at the 12" (305mm) mark. Install the TSA-ODC per its provided instructions.

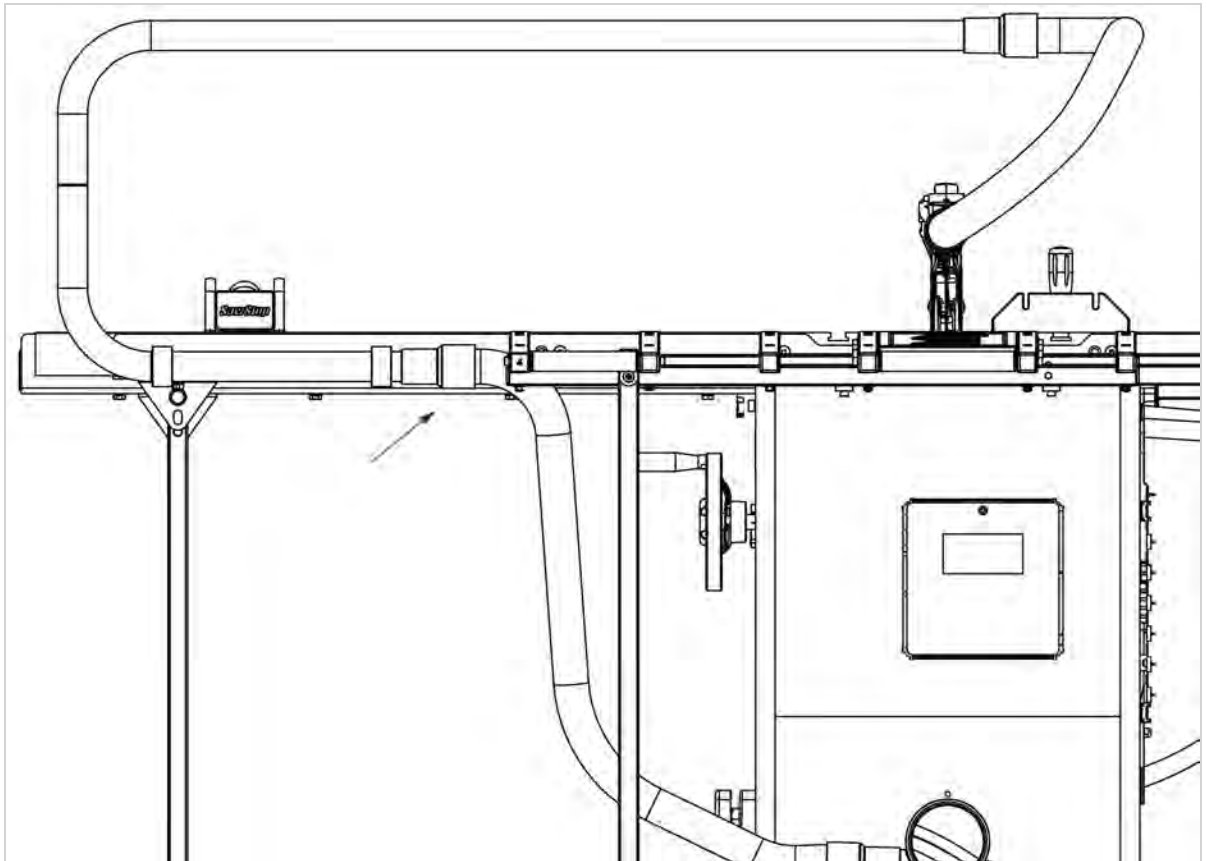

To shift the TSA-ODC to the right:

Install the TSA-ODC per its provided instructions, with one modification: Place the tube clamps near the end of the rear rail, allowing the lower rigid tube to extend 12" from the edge of your extension table.

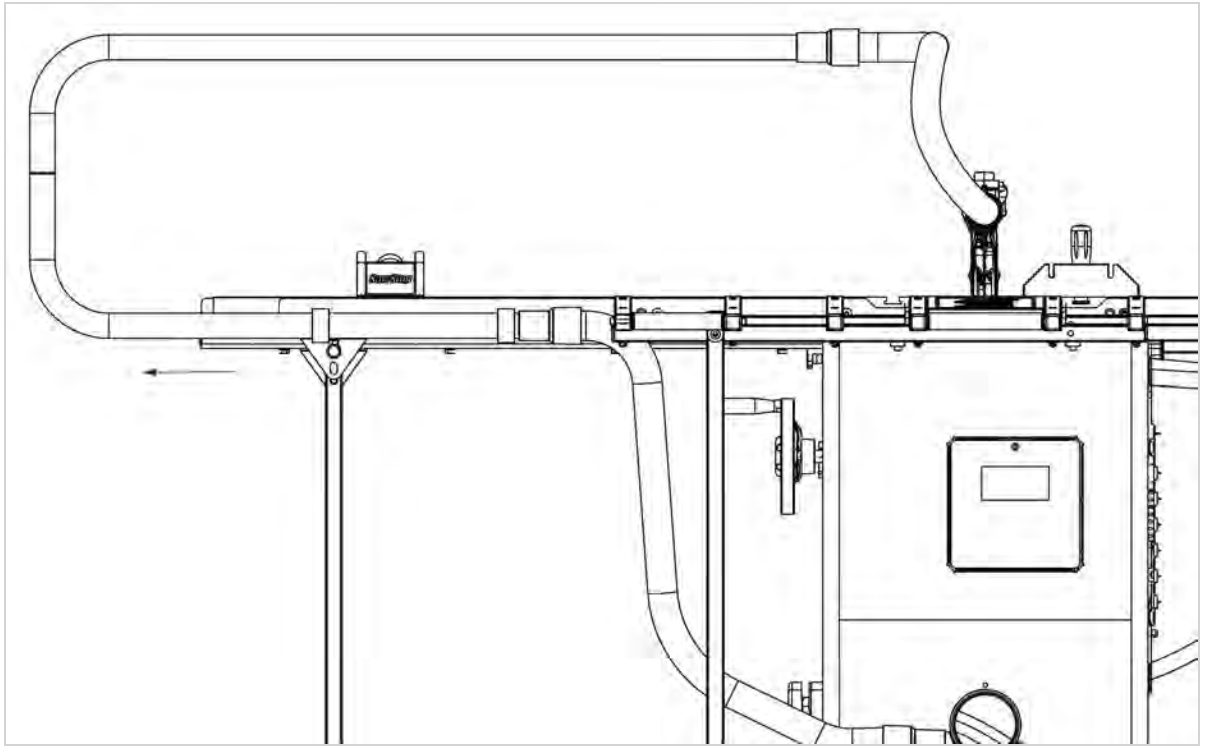

NOTES



NOTES





USA/CANADA

SawStop, LLC

11555 SW Myslony St,
Tualatin, OR 97062 USA

SawStop.com/support

Service@SawStop.com
(503) 582-9934

Parts available for purchase at SawStop.com

EUROPE/UK

TTS Europe SE

Wertstrasse 20
73240 Wendlingen a.N., DE

UK Regulatory

Authorised Rep Compliance Ltd., ARC House,
Thurnham, Lancaster, LA2 0DT, UK.

SawStop.eu/support

SupportEurope@SawStop.com

AUSTRALIA

Carbatec.com.au/contact

customercare@carbatec.com.au