

EN

DE

FR

ES



CTS-230B50UK / CTS-230B50EU

# COMPACT TABLE SAW OWNER'S MANUAL



**CTS**<sup>®</sup>

85-007590-00  
Rev A - 06052024

# TABLE OF CONTENTS

DECLARATION OF CONFORMITY .....	3
SYMBOLS .....	3
SPECIFICATIONS AND REQUIREMENTS .....	4
GET TO KNOW YOUR SAW .....	6
PREPARE YOUR SAW FOR USE .....	11
USING YOUR COMPACT TABLE SAW .....	17
CARING FOR YOUR SAW .....	22
TROUBLESHOOTING .....	37



[www.SawStop.eu/CTSsupport](http://www.SawStop.eu/CTSsupport)

- EN Additional translations of this manual are available from the above URL.
- IT Ulteriori traduzioni di questo manuale sono disponibili all'URL sopra indicato.
- NL Bijkomende vertalingen van deze handleiding zijn beschikbaar via de bovenstaande URL.
- SV Ytterligare översättningar av denna bruksanvisning är tillgängliga via ovanstående URL.
- FI Oppaan muita käännöksiä on saatavilla yllä olevasta URL-osoitteesta.
- DA Der kan findes yderligere oversættelser af denne vejledning på ovennævnte webadresse.
- NB Ytterligere oversettelser av denne håndboken er tilgjengelige på ovenstående internettadresse.
- PT Traduções adicionais deste manual estão disponíveis no URL acima.
- CS Další překlady tohoto návodu jsou k dispozici na výše uvedené adrese URL.
- PL Dodatkowe tłumaczenia tej instrukcji dostępne są pod powyższym adresem WWW.

Copyright SawStop, LLC

All Rights Reserved

Revised June, 2024

Original Instructions - Compact Table Saw

Updates to this manual and additional related documentation such as exploded views and parts lists are available at [SawStop.eu](http://SawStop.eu) or [SawStop.uk](http://SawStop.uk)



# DECLARATION OF CONFORMITY

We declare under our sole responsibility that this product: **Compact Table Saw (CTS-230B50EU, CTS-230B50UK)**

A transportable table saw, complies with all the relevant requirements in the following EU Directives:

- 2006/42/EC – Machinery Directive
- 2014/30/EU – Electromagnetic Compatibility
- 2015/863/EU – RoHS 3

Standards or normative documents:

Health and Safety	EN 62841-1:2015+AC:2015+A11:2022 EN 62841-3-1:2014/A12:2021
EMC	EN 55014-1:2017/A11:2020 EN 55014-2:1997/A2:2008
Environmental	EN 63000:2018



Michael Davies  
Managing Director SawStop Europe  
73240 Wendlingen a.N., DEa.N., DE











Eric Burmester  
Vice President of Engineering  
11555 SW Myslony St. Tualatin, OR, USA

Tualatin, Oregon, USA

Date of Declaration: May 30, 2024

## SYMBOLS

The following symbols, acronyms and abbreviations may also be found on the exterior of your tool or in this manual.

SYMBOL	DEFINITION	SYMBOL	DEFINITION
	High voltage		Warning of general caution or danger
	Protective earth ground	"	Inch
V	Volts	lb	Pound
W	Watts	Kg	Kilogram
~	Hertz (cycles per second)	°	Angular degree
N <sub>o</sub> /min	Revolutions Per Minute	mm	Millimeter
m <sup>3</sup> /hr	Cubic Meters per hour	cm	Centimeter
	Read warnings and instructions		Keep all guards and covers in place
	Use hearing protection		Use eye protection
	Use a dust mask		Do not dispose with household waste

# SPECIFICATIONS AND REQUIREMENTS

## DIMENSIONS

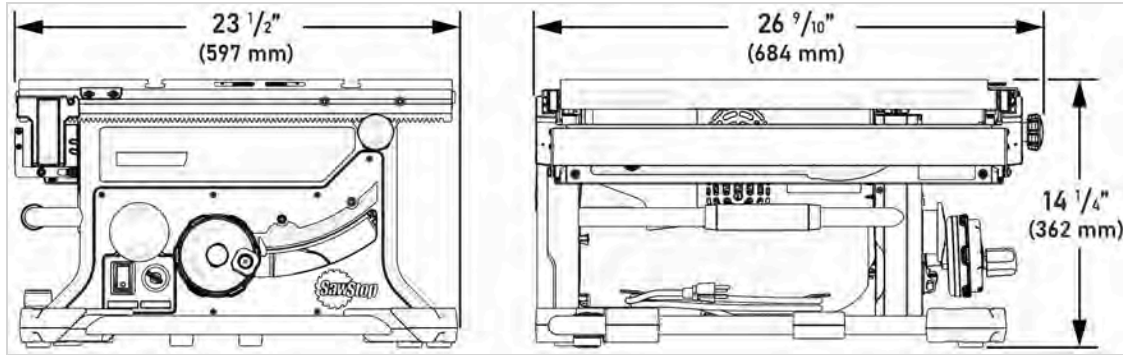

SPECIFICATIONS	
Motor Configuration (EU/UK)	230 VAC 50Hz, Universal
Power	1800 W
No-Load RPM (n0)	4,000
Weight	68 lbs (31 kg)
Shipping Weight	78 lbs (36 kg)
Max. Depth of Cut, Blade at 0°	3 1/8" (79.5 mm)
Max. Depth of Cut, Blade at 45°	2 1/8" (54 mm)
Max. Rip Capacity	24 1/2" (622 mm)

BLADE REQUIREMENTS	
Blade Diameter (A)	10" (254 mm) or 250mm (9.84")
<b>WARNING: Do not use blades smaller than 250mm in diameter.</b>	
Bore (Arbor) Diameter (B)	30 mm
Blade Plate Thickness (C)	0.071" - 0.087" (1.8-2.2mm)
Blade Kerf (D)	0.093" - 0.138" (2.3mm - 3.5mm)
Speed	N <sub>0</sub> : 4000/min
Riving Knife or Spreader Thickness (E)	0.090" (2.3 mm)
Blade and Riving Knife or Spreader Gap (F)	0.16" - 0.32" (4-8 mm)

See callout references on images

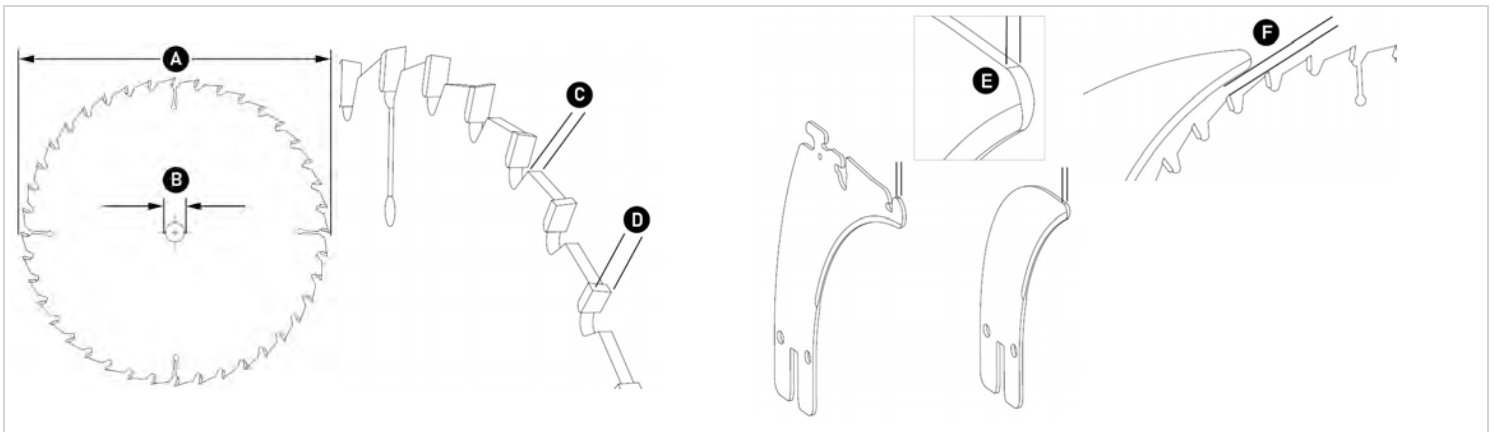

### More about blades:

- Use only saw blades recommended by the manufacturer (see specification on the previous page) that meet EN 847-1.
- Use only blades that conform to the diameter, body thickness and kerf thickness specifications marked on the riving knife included with your saw.
- Use only saw blades that are marked with a speed equal or higher than the speed marked on the tool.
- Use a blade type appropriate for the material being cut.

This illustration shows a blade as equipped with shoulders (A). Do not use blades with shoulders. The shoulders could prevent the brake pawl from effectively engaging the blade in the event of an activation of the safety system.

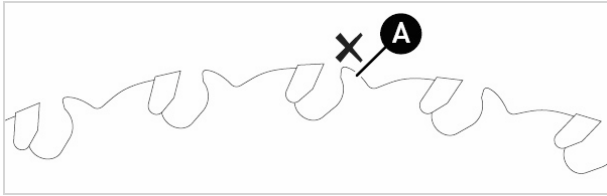

### WARNING:

Do not use undersized blades. Blades smaller than 250mm could increase the chance of a more severe injury in the event of a safety system activation.

### NOTE:

Both the riving knife and the spreader are 0.090" (2.3mm) thick. Do NOT use a blade with a kerf less than 0.093" - 0.138" (2.3mm - 3.5mm) with this tool. When the blade and riving knife or spreader are installed in the saw, there should be a gap of 4-8mm between the blade and the riving knife or spreader.

### IMPORTANT:

Avoid overheating the tips of the saw blade teeth by keeping the blade clean and sharp. Ensure the dust collection system is clean and free of debris. When cutting plastic, make sure material feed rate does not cause the plastic to heat up or melt.

### WARNING:

To avoid risk of injury, wear gloves when handling saw blades. Never wear gloves when operating the saw.

The saw can be used to cut wood, plastic, pliable metal (e.g., aluminum), or other similar materials. Do not use the saw to cut ferrous metals. Conductive materials must be cut using Bypass Mode (see **BYPASS MODE** on page 21).

## NOISE EMISSIONS LEVELS

The levels determined in accordance with EN 62841 are typically:

Sound pressure level	Lpa = 99.4 dB
Sound power level	Lwa = 112.4 dB, LpCpeak = 102 dB
Uncertainty	3 dB

The specified noise emission values

- have been measured in accordance with a standardised test procedure, can be used to compare one power tool with another,
- and can also be used for a provisional assessment of the load.

### WARNING:

Noise generated when working. Risk of damage to hearing. Use hearing protection.

Noise emissions during actual use of the power tool can differ from the declared values depending on the ways in which the tool is used especially what kind of workpiece is processed.

It is important for the operator to identify safety measures to protect the operator that are based on an estimation of exposure in the actual conditions of use (taking account of all parts of the operating cycle such as the times when the tool is switched off and when it is running idle in addition to the trigger time).

## ELECTRICAL CONNECTION

See the included **Safety and General Use Instructions for Portable Table Saws** manual for additional general specifications and safety warnings.

# GET TO KNOW YOUR SAW

## OVERVIEW

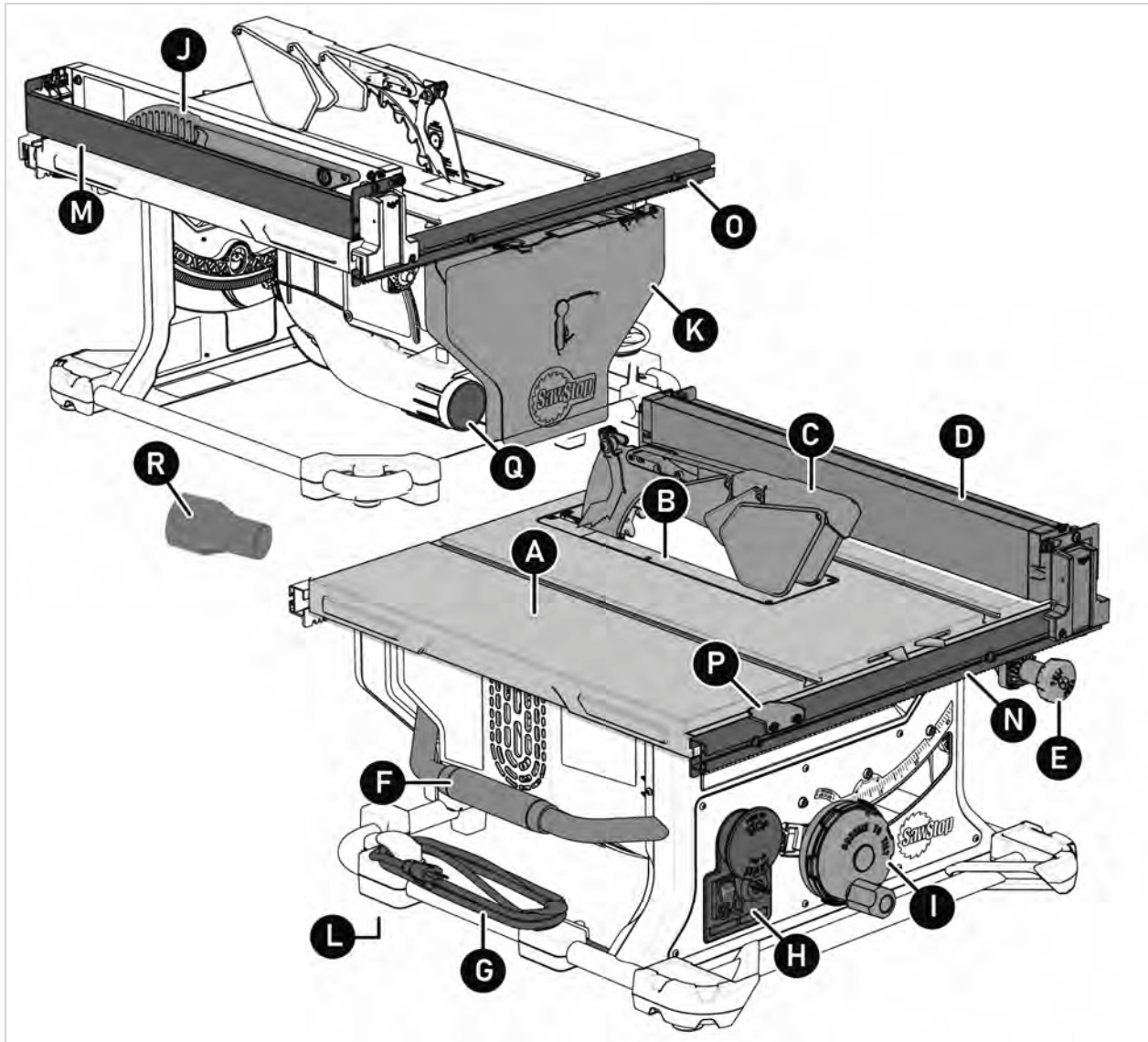

- |                      |                                  |                               |
|----------------------|----------------------------------|-------------------------------|
| A. Table             | G. Power Cord                    | M. Shelf and Low Fence        |
| B. Insert            | H. Power Controls                | N. Fence Rail, Front          |
| C. Blade Guard       | I. Bevel and Elevation Controls  | O. Fence Rail, Rear           |
| D. Rip Fence         | J. Push Stick                    | P. Position Indicator Lens    |
| E. Rip Width Control | K. Accessory Storage Compartment | Q. Dust Collection Connection |
| F. Carry Handle      | L. Leveling Foot                 | R. Dust Collection Adapter    |



## ACCESSORIES

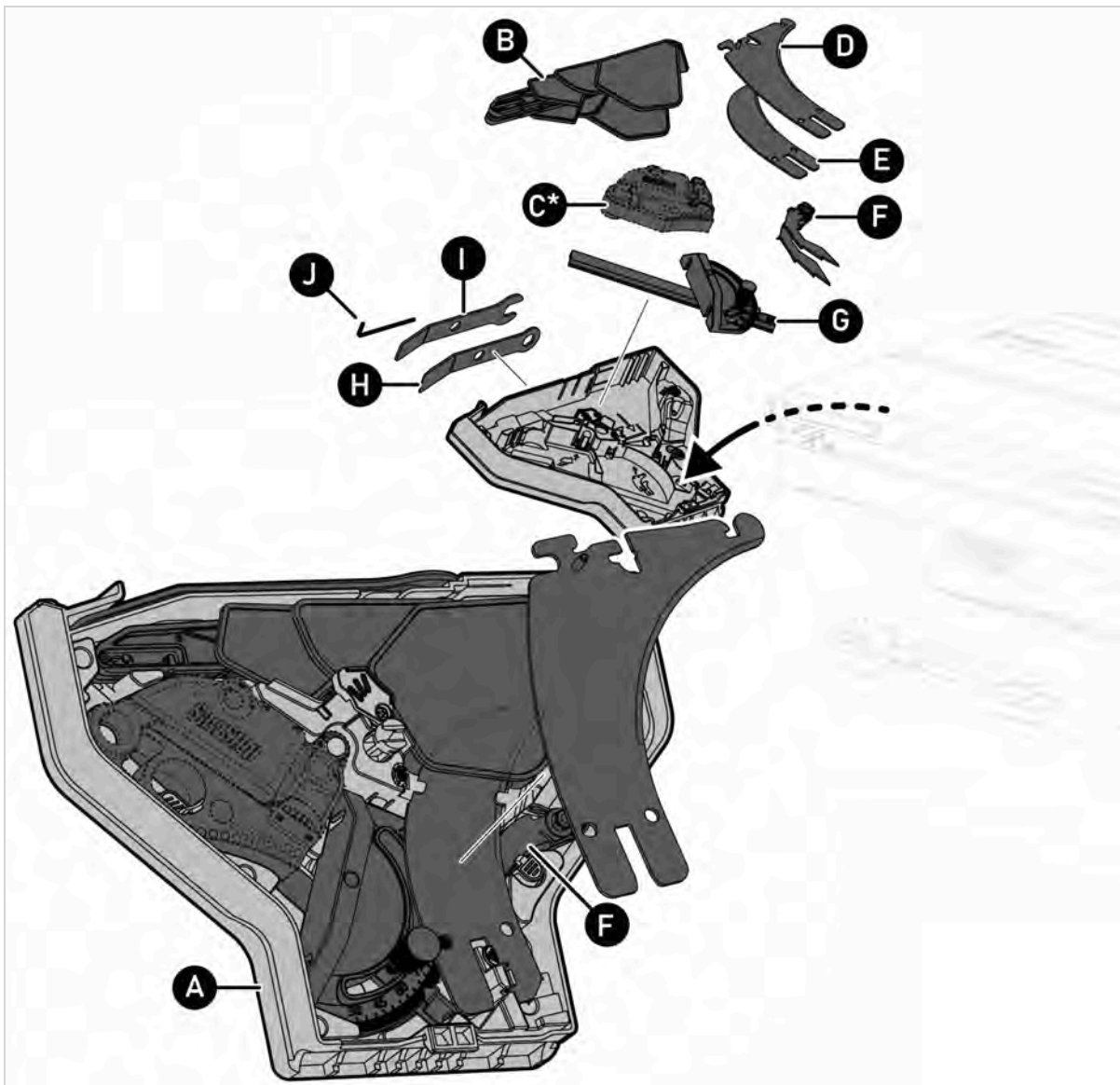

- |                                  |                           |                        |
|----------------------------------|---------------------------|------------------------|
| A. Accessory Storage Compartment | E. Riving Knife           | I. Arbor Flange Wrench |
| B. Micro Guard                   | F. Anti-Kickback Pawls ** | J. Hex Wrench          |
| C. Brake Cartridge *             | G. Miter Gauge            | K. Stand (Optional)    |
| D. Spreader                      | H. Arbor Nut Wrench       |                        |

\* A brake cartridge is included with and installed on the saw. You can also purchase an additional brake cartridge (C) (visit [SawStop.eu](http://SawStop.eu) or [SawStop.uk](http://SawStop.uk)) and keep in the storage compartment (the extra brake cartridge is shown as-stored in the accessory storage compartment).



### WARNING:

Use only the CTS-compatible version TSBC-10R3 of the brake cartridge. (Check the part number and suitability on packaging.) Previous versions of the brake cartridge are not compatible with the Compact Table Saw.

\*\* Optional accessory available for purchase through the SawStop parts store.

## STAND (Optional)

You can mount the saw on the optional SawStop folding stand (part number CTS-FS; to order visit [SawStop.eu](http://SawStop.eu) or [SawStop.uk](http://SawStop.uk)). To learn how to mount the saw on the stand see the instructions included with the stand.



## POWER CONTROLS

- A. Main power switch
- B. Start/stop paddle
- C. Bypass mode switch, with lockout feature (see page 21)
- D. Lockout slots

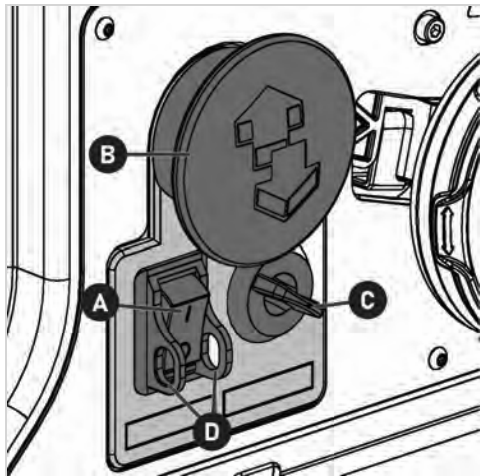

Use the main power switch (A) to control power to the saw.

Use the start/stop paddle (B) to turn the motor on (spin the blade) and off (see page 20).

Use the bypass mode switch (C) (see page 21) to activate bypass mode and to disable bypass mode.

## LOCKOUT

Place a padlock through the lockout slots to prevent the saw from being turned on.

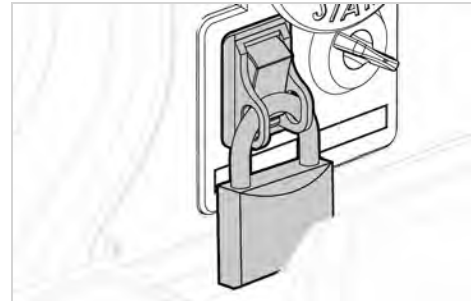

## NORMAL MODE AND STANDBY MODE

Normal Mode is the regular operating mode when the saw is running, the mode you use to cut non-conductive materials.

Standby Mode is when the saw is not running but ON.

The safety system is active in both modes.

## BYPASS MODE

Use Bypass Mode to 1) determine if a material is conductive 2) disable the safety system so you can cut conductive materials. (see page 21)

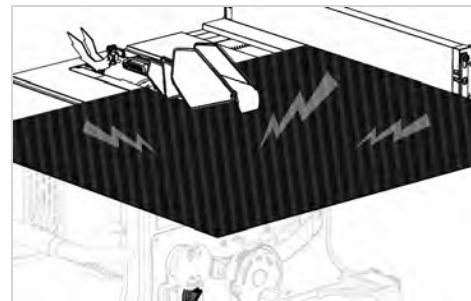

There is no protection in Bypass Mode; the brake will not activate if your skin touches the spinning blade. Use Bypass Mode only to test a material for conductivity and to cut conductive materials.

## STATUS LIGHT CODES

The green (A) and red (B) lights under the power controls indicate the status of the saw. The lights can display

individually or in combination, depending on the status. Either light can flash slowly or quickly. Either light can display as solid.

The red light can flash once indicating the saw is in Bypass Mode.

(See **STATUS LIGHTS & CODES** on page 17.)

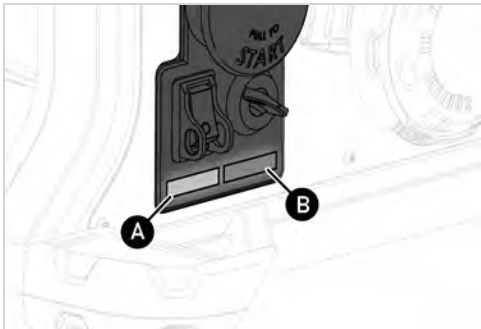

## ZERO-CLEARANCE INSERT

Your Compact Table Saw uses a 'zero-clearance' insert (A). The zero clearance slot (B) is pre-cut at the factory. The zero-clearance slot maximizes support under narrow cuts and reduces risk of kickback. You will need to cut the slot in replacement inserts (see page 24).

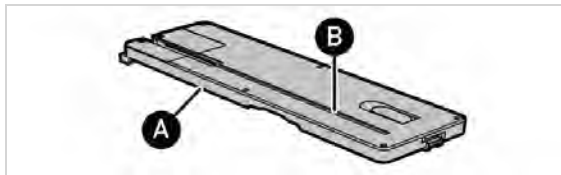

### How to Remove the Insert

1. Insert the included 4mm hex wrench into the hole on the latch of the table insert.



2. Push the top of the hex wrench away from you to release the latch.

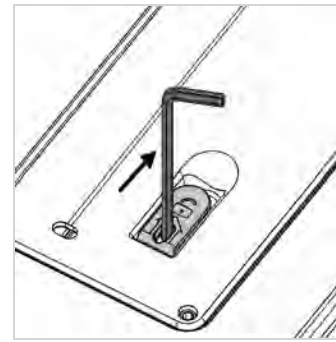

3. Lift the insert slightly and pull it toward you to remove.

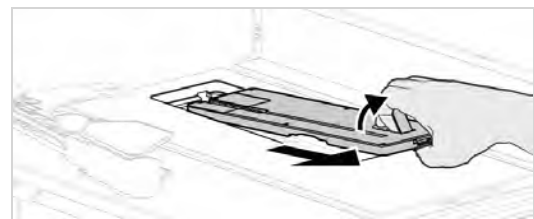

## BLADE GUARD

The blade guard consists of a micro guard (A), anti-kickback pawls (B)\* and spreader (C). Always use the blade guard when making through-cuts. Use the low fence (see page 12) for thin cuts and narrow cuts.

The micro guard helps prevent contact with the blade.

The anti-kickback pawls\* help reduce the likelihood of kickback.

The spreader provides a mount for the micro-guard and anti-kickback pawls\* and helps prevent pinching and binding, which reduces the likelihood of kickback. To learn how to assemble the blade guard, see page 13.

### **i** NOTE:

\*Anti-kickback pawls are an optional accessory available for purchase through the online SawStop parts store.



## WARNING:

Always use the blade guard whenever possible. If the cut type will not permit use of the blade guard, use the riving knife. See the **Cut Types** section of the **Safety and General Use Instructions for Portable Table Saws** manual included with your CTS.

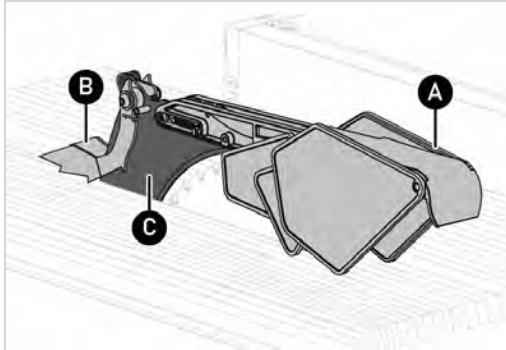

To cut, raise top of blade above material. Place material flat on table and push slowly and smoothly into blade. Guard will adjust to material height.

## RIVING KNIFE

Like the spreader, the riving knife (A) helps prevent pinching and binding, which reduces the likelihood of kickback.

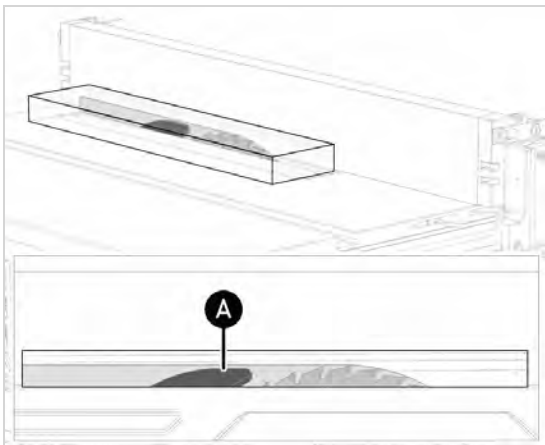

Use the riving knife instead of the blade guard when 1) a rip cut is too narrow for clearance between the blade guard and the rip fence or 2) you are making a non-through cut (the blade does not pass all the way through the thickness of the material), as shown in the illustration, above.

## INTEGRATED BLADE CONTROL

Elevation and bevel are combined in one control.

Rotate the wheel clockwise to raise the blade (A), counter-clockwise to lower the blade (B).

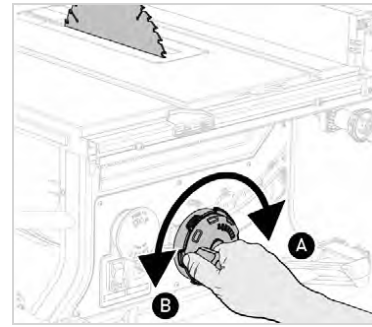

Squeeze and hold to unlock the bevel control (C), and then set the bevel (D). The maximum bevel angle is 45°.

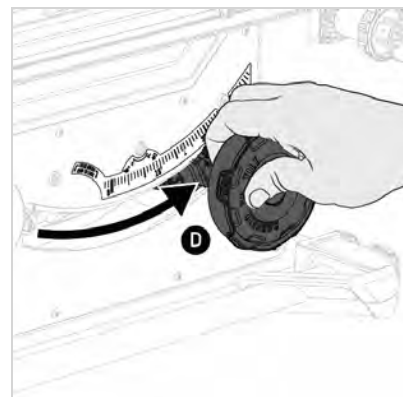
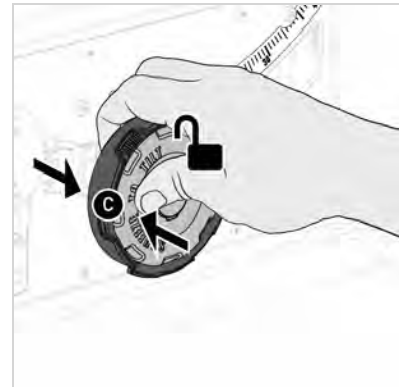

The bevel wheel has three positions:

- Unlocked, when you squeeze the wheel
- Middle; the wheel snaps to this position when you stop squeezing the wheel
- Locked, when you push the wheel towards the saw

With the bevel wheel in the middle position, turn the wheel to fine-tune the bevel, as needed (E).

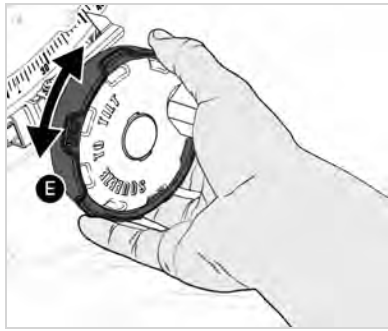

Push the wheel to lock the bevel (F).

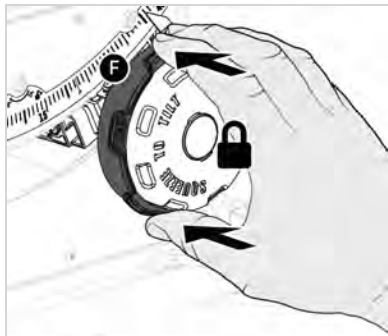

## PREPARE YOUR SAW FOR USE

### SOLID, LEVEL & CLEARANCE

Place the saw on a solid and level working surface. If using the saw on the optional stand (see page 8), place the stand on solid level ground or floor. Make sure there is enough space around the saw so that you can cut the workpiece without interference (A).

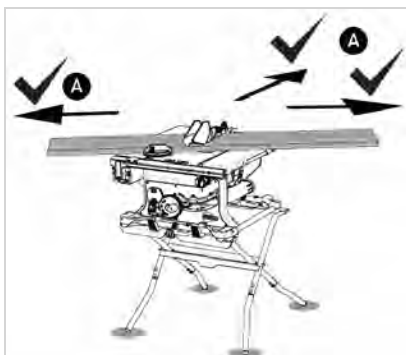

Also, make sure the workpiece is not too large to safely control as you make the cut. Make sure that you are able to

prevent the workpiece from overbalancing as you pass the workpiece across the table and complete the cut.

### LEVELING FOOT

You can adjust the leveling foot, as needed, when placing the saw on a surface. If mounting the saw on the stand, screw the leveling foot all the way in (towards the frame).

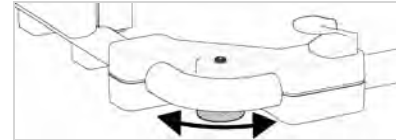

### HOW TO TRANSPORT & STORE

To transport or store the saw:

- Turn off the saw, and then lock out the power switch (A) (see page 8).
- Place the rip fence in the storage position (B).
- Remove the blade guard, and then disassemble and place the parts in the accessory storage compartment (see page 7).
- Fully lower the blade.
- Wind the power cord (C).
- Make sure the bevel control is locked (D).
- Make sure the rip-width control is locked (E).
- Use the carry handle (F) to carry the saw and the frame rail on the opposite side, as needed. It is recommended that two people carry the saw.
- The saw weighs 68 lbs (31 kg).

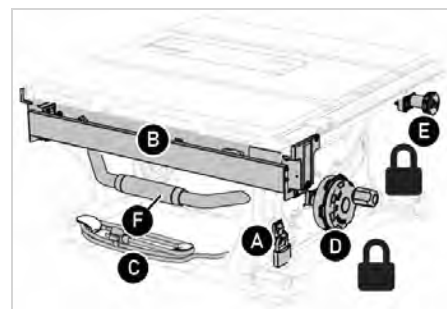

### HOW TO PLACE THE RIP FENCE

Use the rip fence for all rip cuts. (For details, see the **Cut Types** section of the **Safety and General Use Instructions for Portable Table Saws** manual included with your CTS.)

Move the rip fence from the storage location to a working position:

1. Push the two latches (A) (one on either end of the rip fence) to unlock. Lower the rip fence (B) away from the rails.

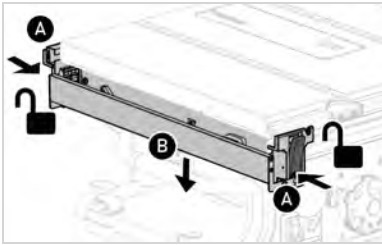

**WARNING:**

To help reduce the risk of kickback, always use the rip fence for rip cuts (with the grain). **DO NOT** use the rip fence for cross cuts. Use the miter gauge for cross cuts.

2. Flip the rip fence over (C), and then place on the adjustable lugs (D) (see the next image), and then push the latches to lock the rip fence (E). Make sure the working face (F) is towards the blade.

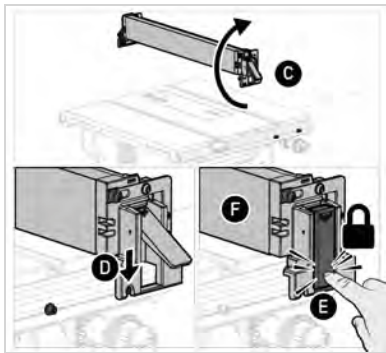

**Adjustable Mounting Lugs**

There are three sets of adjustable lugs (three lugs on the front rail, three lugs on the rear rail). You must mount the rip fence on one of the lug sets.

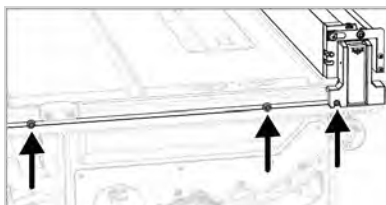

Use the lug set that's to the right of the blade, farthest from the blade, for rip cuts in general or to use the saw's widest rip capacity.

Use the lug set that's to the right of the blade, nearest the blade, for rip cuts in general.

Use the lug set to the left of the blade if you need to make a rip cut on that side of the saw.

See **USING YOUR COMPACT TABLE SAW** on page 17.

**WARNING:**

Make sure you place the rip fence on the correct set of mounting lugs so that the face of the rip fence is parallel to the saw blade.

**How to Store the Rip Fence**

With the rip fence upside down, place and hold (A) the rip fence under the left side of the table, on the lugs, and then lock the latches on both sides of the rip fence (B).

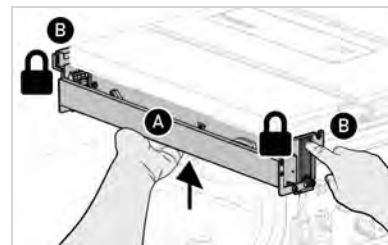

**Rip Width Control**

Use the rip width control (A) to set the rip fence to the desired rip cut width. To learn how to use the ruler to set rip width, see page 17.

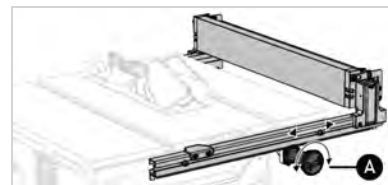

## Low Fence

The low fence (A) has two positions so you can use the mechanism as a low fence or as a shelf. Use the low fence position to make narrow rip cuts and still permit use of the blade guard. When using the low fence, subtract 2 inches (50.8mm) from the ruler to allow for the width of the low fence.

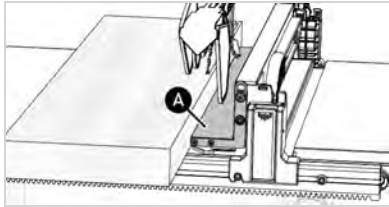

## Shelf

Use the shelf position (A) to support workpieces when the rip fence is extended to the right such that the workpiece could over-center and tip down (see **USING YOUR COMPACT TABLE SAW** on page 17).



For instructions on adjusting the vertical shelf position at full extension, please visit the Support page at [SawStop.eu](http://SawStop.eu) or [SawStop.uk](http://SawStop.uk) and locate the service bulletin called **Compact Table Saw Puck Adjustment Procedure**.

## FENCE STOPS

If the fence contacts the blade, the brake cartridge will activate. The fence stops are designed to prevent the rip fence from contacting the blade when:

- The rip fence is mounted to the right of the blade on the mounting lugs closest to the blade
- The rip fence is mounted on the lugs to the left of the blade

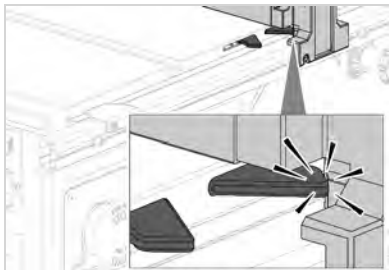

If required, you can override the fence stops by pushing and holding them in while you adjust the rip fence to pass over the stops. In this situation, take extra care that you do not cause the rip fence to contact the blade, which will result in an activation.

### **WARNING:**

When the fence stops are retracted, you must use extra caution to prevent contacting the blade with the rip fence.

The low fence is typically used when you need to make a cut that is narrower than the stops permit. Always use extra caution when using the low fence as the fence stops will not prevent the low fence from contacting the blade.

### **WARNING:**

Never override the fence stops to make a narrow cut. Always use the low fence to make narrow cuts.

## HOW TO ASSEMBLE THE BLADE GUARD

The chief device to help prevent kickback is the blade guard. Make sure the blade guard is assembled correctly and functioning properly. Learn more about kickback causes and precautions in the **Safety and General Use Instructions for Portable Table Saws** manual included with your Compact Table Saw.

## Anti-Kickback Pawls

### **NOTE:**

Anti-Kickback Pawls are an optional accessory available for purchase through the online parts store at [SawStop.eu](http://SawStop.eu) / [SawStop.uk](http://SawStop.uk).

The blade guard is stored in the accessory storage compartment in three pieces: the spreader, the anti-kickback pawls and the micro guard.

Attach the anti-kickback pawls to the spreader:

1. Place the loop end of the spring in the notch located near the back of the spreader (A).



2. Pull the pawl bushing over (B) and into the rear slot (C).

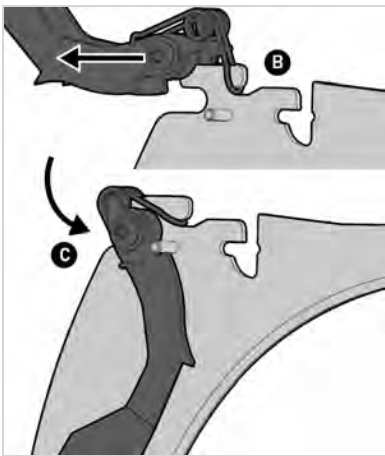

### Micro Guard

Next, attach the micro guard (A) to the spreader:

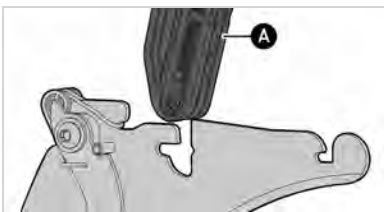

1. Slide the rear pin (B) into the middle slot.

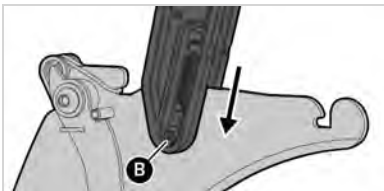

2. Pivot the micro-guard towards the spreader. The front pin (C) will contact the top of the spreader.

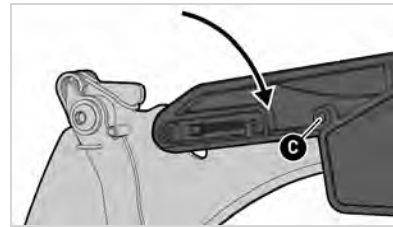

3. Pull and pivot the micro-guard until the front pin pops into the front slot.

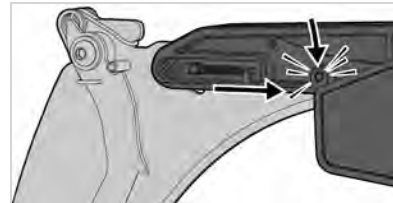

## HOW TO ATTACH THE BLADE GUARD OR RIVING KNIFE

### **i** NOTE:

The following instructions apply to both the riving knife and the blade guard.

1. Remove the table insert.
2. Turn the elevation wheel clockwise to fully raise the blade.
3. Pivot the handle up to open the clamp for the blade guard.

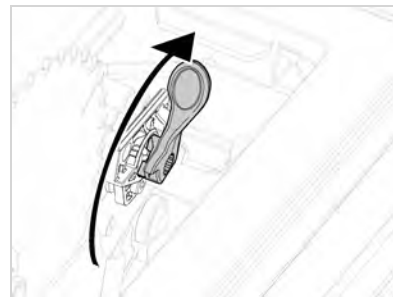

4. Insert the blade guard or riving knife into the clamp.

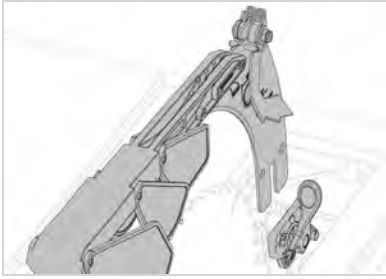

5. Fit the two holes in the spreader over the mounting pins (A).

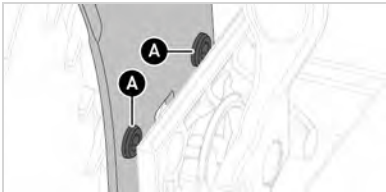

6. Pivot the handle down to close the clamp.

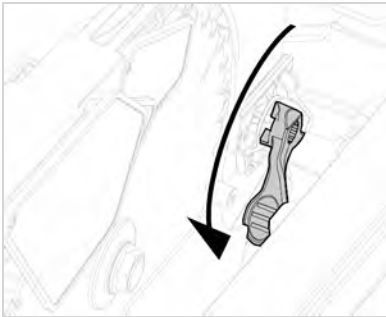

To learn how to adjust clamping force of the blade guard clamp, see page 29.

## HOW TO DISABLE THE ANTI-KICKBACK PAWLS

### NOTE:

Anti-Kickback Pawls are an optional accessory available for purchase through the online parts store at [SawStop.eu](http://SawStop.eu) / [SawStop.uk](http://SawStop.uk).

The anti-kickback pawls help reduce the chance of kickback and potential injury or property damage. The pawls are spring-loaded and designed to engage the workpiece if the workpiece moves towards the front of the saw. The pawls ride against the top of the workpiece as you make the cut. As you finish the cut, push the workpiece entirely past the back of the blade and the pawls, disengaging the workpiece from the pawls. The pawls are used for any cutting situation

where the blade guard is used. It's also possible to disable the pawls for exceptions as needed.

Rotate both pawls up until they over-center (A) and remain in the up and disabled position. You must rotate both pawls simultaneously.



To enable the pawls, rotate the pawls back down into the working position.



### WARNING:

Disable the anti-kickback pawls only for exceptions.

## HOW TO ATTACH A DUST COLLECTOR

Your Compact Table Saw uses a below-table dust collection design; we recommend that you connect a dust collection system to the outlet port on the dust shroud.

Connect a dust collection system, which provides at least 170 CFM (4800 LPM) of airflow, to the dust port at the back of the saw. You can attach it to the outer diameter or inner diameter of the port. The outer diameter (A) is 2.5" (65 mm). The inner diameter (B) is 2.3" (58 mm).

Larger diameter hoses will result in more efficient dust collection.

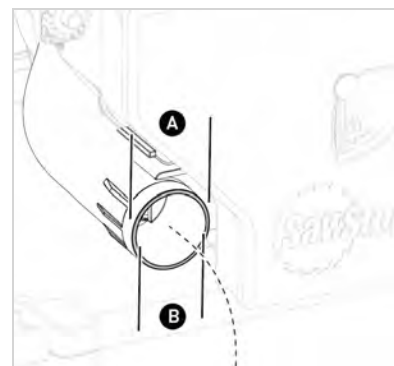

Some commonly available 50mm inner diameter hoses can be inserted directly into the dust port. The included dust

port adapter is provided for convenient connection to commonly available 36mm and 27mm dust hose sizes.

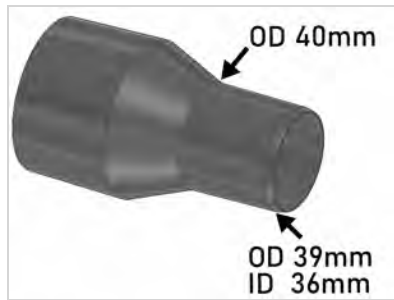

*Dust port adapter - Hose fitting dimensions*

Always use a dust collection system when making cuts.  
Keep the system free of accumulated dust and debris.

# USING YOUR COMPACT TABLE SAW

## STATUS LIGHTS & CODES

The green and red lights under the power switch indicate the status of the saw. The lights function independently or in combination, depending on the status. Either light can flash slow or fast, or be on continuously. The red light can flash once indicating the saw is in Bypass Mode see page 21.

Error codes not listed may also appear. If you are not able to identify the code or resolve an error situation, contact the SawStop Service department. Visit [SawStop.eu/contact](http://SawStop.eu/contact) for contact information.

See the descriptions of the status conditions in the table below.

GREEN	RED	STATUS	DESCRIPTION
Solid on	Slow blink	Starting up	The system is performing self-checks and energizing the brake system. This code should clear within 15 seconds after you turn on the power switch. If the ambient temperature is very low (below about 0° F), this code may take longer to clear.
Solid on	Off	Ready or running	All self-checks have been completed, the safety system is operating properly, and the saw is in Standby Mode and ready to run.
Fast blink	Off	Coasting down	The blade is coasting down and that the safety system is ready to activate the brake if contact is detected. The safety system monitors the rotation of the blade while it is coasting down. If you touch the blade while this code is flashing, the brake will activate.
Slow blink	Off	Bypass Mode ON*	The saw is running in Bypass Mode and will NOT activate the brake cartridge if you contact the spinning blade. Bypass Mode allows you to cut electrically conductive materials without activating the brake. When the saw is in Bypass Mode, the safety system is disabled.
Fast blink	Fast blink	Paddle OUT	The Start/Stop paddle is in the ON position (pulled out) before you turn on the power switch. Push the paddle in to the OFF position to clear this code. This is a safety feature to prevent the saw from restarting after a power loss or after the safety system has turned the saw off due to an error detected during use.
Off	Fast blink	Blade contact while stopped	There was contact with the blade (or a portion of the arbor) when the blade was not spinning in Standby Mode. Contact in this mode does not activate the brake. The code will automatically clear within 5 seconds after contact has ended. The system will not allow the motor to start while this code is displayed.

GREEN	RED	STATUS	DESCRIPTION
Solid on	Fast blink	Blade contact during bypass	Contact was detected while the saw was running in Bypass Mode. The code indicates that the brake would have activated if the system had not been in Bypass Mode. The brake will not activate but the safety system will continue to monitor for contact. This error will automatically clear once the blade has finished coasting down.
Off	Slow blink	Brake cartridge key error	The cartridge locking key is not installed correctly. To clear this error, first turn the power switch to OFF, and then make sure the cartridge key is fully locked (see page 27).
Off	Fast blink	Overload due to moisture	The material is too wet or green. Cycle the Start/Stop paddle and the power switch to clear. Allow material to dry or cut in Bypass Mode.
Slow blink	Solid on	Small or missing blade	There is no blade currently installed or the blade is too small and thus incompatible with your Compact Table Saw. Switch power off, unplug the power cord and install a 10" (250mm) blade.
Fast blink	Solid on	No blade rotation	The blade is stalled. Cycle power and cut material more slowly. Contact SawStop Technical Support if issue persists. (See <a href="http://SawStop.eu/support">SawStop.eu/support</a> ).
Off	Solid on	Replace brake cartridge	The brake cartridge has already activated or there is some other defect that cannot be corrected. If the cartridge has not activated, cycle the power off and on. If the error continues, install a new cartridge. For instructions on changing the brake cartridge see page 27.
Slow blink	Slow blink	Switch box error	Both lights flash slowly together (synchronized). This code indicates an error with the electrical system. The error is not user-serviceable—contact SawStop Service for assistance. (See <a href="http://SawStop.eu/support">SawStop.eu/support</a> ).



**WARNING:**

\* THERE IS NO PROTECTION IN BYPASS MODE; the brake will not activate if you touch the spinning blade. Use Bypass Mode only to test a material for conductivity and to cut conductive materials. Use extra caution in Bypass Mode.

## HOW TO SET THE RIP WIDTH

Understand the difference between rip cuts and cross cuts before cutting. (See the **Cut Types** section of the **Safety and General Use Instructions for Portable Table Saws** document included with your saw.)

See **HOW TO PLACE THE RIP FENCE** on page 11 to learn how to place the rip fence on the mounting lugs.

1. Pull the rip width control to unlock the rail mechanism.

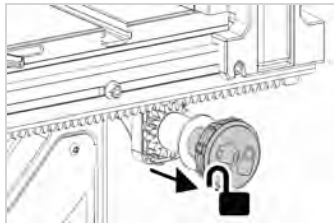

2. Turn the control to adjust the width. Look directly down on the lens position indicator (A) and the ruler to determine the rip width. See the following section to learn how use the ruler.

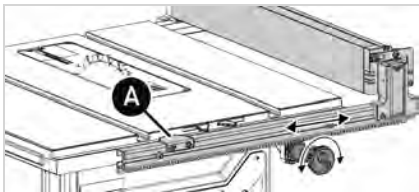
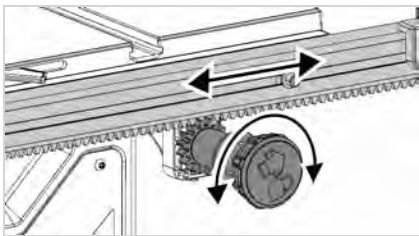

3. Push in the control to lock the mechanism.

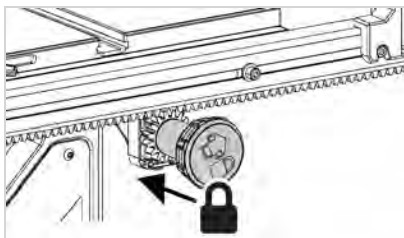

## HOW TO USE THE RULER

When you mount the rip fence on the lugs closest to and to the right of the blade (A), use the upper scale (B) on the ruler.

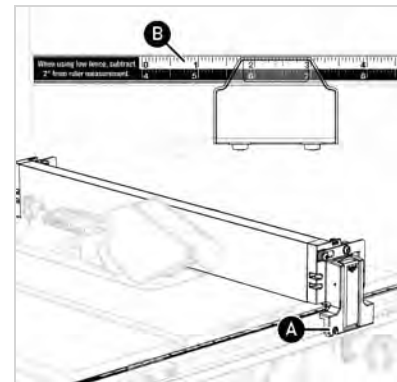

See **HOW TO USE THE LOW FENCE** below.

When you mount the rip fence on the lugs farthest from and to the right of the blade (C), use the lower scale (D) on the ruler.

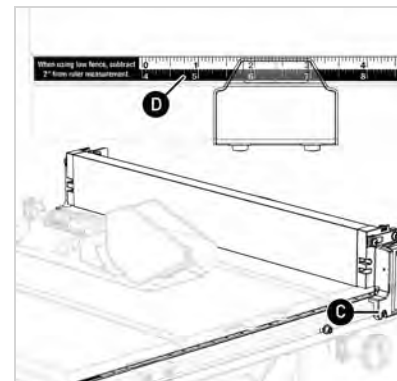

Though the lugs are adjustable, note that they must be precisely 4 inches (101.6 mm) apart to be in sync with the rulers. Additionally, the rip fence must be properly aligned with the blade to ensure the ruler accurately represents cut widths. To learn how to adjust alignment for the rip fence, see page 33.

## HOW TO USE THE LOW FENCE

### **WARNING:**

Never override the fence stops (see page 13) to make a narrow cut. Always use the low fence to make narrow cuts.



## WARNING:

The fence stops will not prevent the low fence from contacting the blade. When adjusting rip width, use extra caution to prevent the low fence from contacting the blade.

1. Pivot the low fence (A) from its storage position on the right side of the rip fence to the left side of the rip fence.

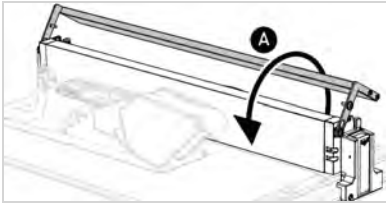

2. Place the two position screws (B) next to the low fence position (the upper slots) (C) on the rip fence.

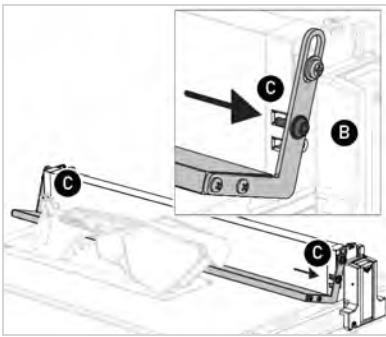

3. Push the position screws into the slots.

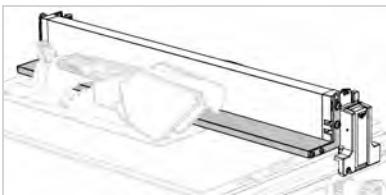

When using the low fence, subtract two inches (50.8 mm) from the value indicated on the ruler (see **HOW TO USE THE RULER** on the previous page).

## How to Use the Shelf

Use the shelf to support workpieces when making rip cuts when the rip fence is extended far enough that the workpiece could tip.

Like the low fence, pivot the shelf into position but place the position screws in the lower slots (A) (instead of the upper slots) in the rip fence.

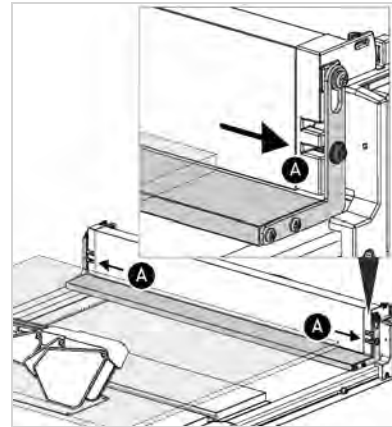

## HOW TO START THE SAW

1. Make sure the table top is clear and that nothing is touching the blade.
2. Turn on the power switch (A).



The red status light will blink slowly for a moment while the safety system initializes. When the safety system is ready, the red status light will turn off and the green status light (B) will turn on, and display steadily (see **STATUS LIGHTS & CODES** on page 17).

When the initialization process is complete, you can pull the Start/Stop paddle (C) to spin the blade.

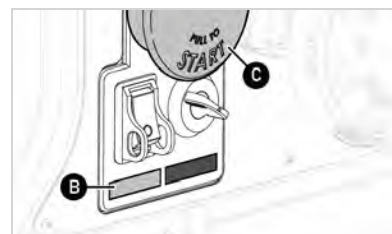



### WARNING:

Make sure the workpiece is not touching the blade when starting the motor.

## How to Restart After Stalling

Be aware that if the blade stops, for example, as due to binding or tough material, you will need to cycle the Start/Stop paddle. Depending on the circumstances, it may also be necessary to cycle the power switch.

## HOW TO STOP THE SAW

1. Press the Start/Stop paddle to cut off power to the motor. Notice also that the paddle is designed to be easy to see and strike in an emergency situation.
2. Turn off the power switch to fully turn off power to the saw.

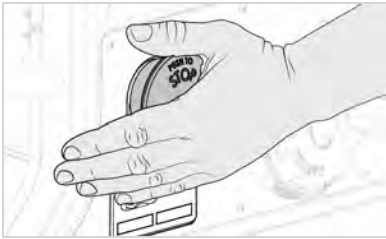

### WARNING:

Always turn off and unplug the saw before working on or maintaining the saw.

## BYPASS MODE

Use Bypass Mode when 1) you're not sure if a material is conductive and you need to test for conductivity or 2) you need to cut a conductive material.

Bypass Mode operates as the name suggests: when on, Bypass Mode prevents the brake cartridge from activating if the spinning blade contacts conductive material.



### WARNING:

THERE IS NO PROTECTION IN BYPASS MODE; the brake will not activate if you touch the spinning blade. Use Bypass Mode only to test a material for conductivity and to cut conductive materials. Use extra caution in Bypass Mode.

## Conductive Materials

The following lists some examples of conductive materials:

- Green or very wet wood
- Wet pressure-treated wood
- Very wet plywood or OSB
- Aluminum and other metals
- Carbon-filled materials
- Foil
- Mirrors

## How to Start in Bypass Mode

You'll need both hands free to activate Bypass Mode.

1. Turn on the power switch (A).

Wait for the solid green status light (B) to display alone.

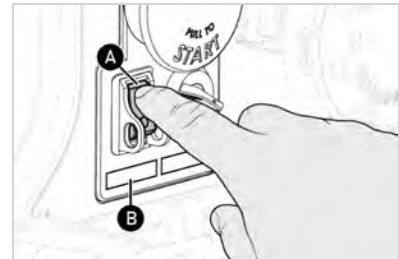

2. Turn the Bypass Mode switch (C) clockwise all the way to the stop and hold in that position.

The red status light (D) should flash once.

Do not release the switch - continue to hold.

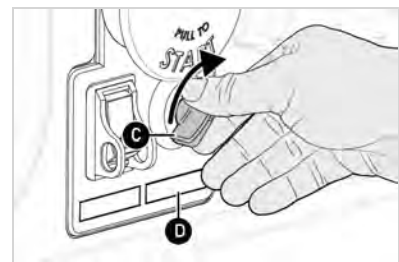

3. While holding the Bypass Mode switch, pull the Start/Stop paddle (E).



The red status light should flash once.  
The blade will spin up.

4. Release the bypass switch (C).  
The switch will spring back to its original position.  
The green status light will flash (B) slowly while the saw is in Bypass Mode.

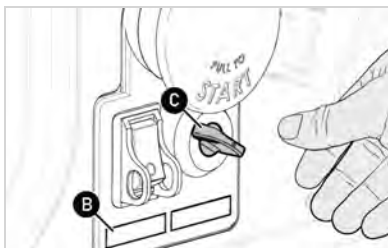

If the material is conductive, the red status light will also begin to flash rapidly (see **STATUS LIGHTS & CODES** on page 17) as soon as the material contacts the spinning blade and will continue to flash until you exit Bypass Mode.

To exit Bypass Mode, press the Start/Stop paddle. The green status light will flash rapidly as the blade spins down.

The safety system returns to the normal protection mode automatically and will be active the next time you start the saw normally.

## How to Prevent Use of Bypass Mode

You can lockout (disable) Bypass mode.

1. Pull out and hold the Bypass Mode switch.

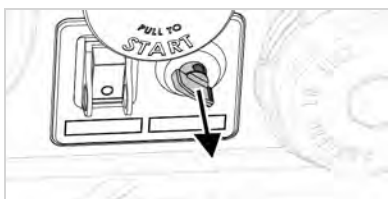

2. Place a lock through the hole in the switch shaft.



## CARING FOR YOUR SAW

Your Compact Table Saw was designed to minimize maintenance. With minimal care, you can keep your saw in efficient and safe working condition.

## TOOLS NEEDED FOR MAINTENANCE

Some of the following tools are included in the accessory storage compartment, as noted:

### Included

- Arbor nut wrench—use to loosen or tighten the arbor nut and to help remove an activated blade and brake cartridge
- Arbor flange wrench—use to keep the arbor from turning as you loosen or tighten the arbor nut
- Hex wrench, 4 mm—use to adjust the blade guard clamp and the rip fence mounting lugs

### Not Included

- Straight-edge—use to determine blade clamp alignment
- Combination square—use to help align the blade, and to align the head of the miter gauge
- Hex wrench, 5 mm—use to help adjust blade alignment
- 10 mm socket or wrench—use to help adjust blade alignment
- Feeler gauge—use to determine blade clamp alignment and blade alignment
- Marker pen—use to assist with blade alignment
- Vacuum—use to remove debris from the saw internal areas
- Phillips screwdriver—use to align the head on the miter gauge

- Flat blade screw driver, or similar tool—use to unlock the latch for the dust shroud door
- C-clamps—use to hold the support or backing board in place when cutting a slot in replacement inserts

## USER REPLACEABLE PARTS AND ACCESSORIES

DESCRIPTION	PART #
Folding saw stand	CTS-FS
Saw table insert	CTS-TSI-I
Microguard	CTS-MG
Riving knife	10"/ 254mm: CTS-051 250mm: CTS-072
Brake cartridge	TSBC-10R3
Spreader	CTS-050
Anti-kickback pawls	CTS-048

## HOW TO ORDER PARTS

Visit [SawStop.eu](http://SawStop.eu) or [SawStop.uk](http://SawStop.uk) for the exploded views and part numbers document for your Compact Table Saw. The replacement parts you identify can then be ordered through the online parts store.

## KEEP THE MOTOR HOUSING & TRUNNION HOUSING CLEAN

Keep the interior of the saw (A) free of accumulated saw dust, wood chips and other debris. Though it is normal to have some dust collect inside the saw, periodically check for dust inside the motor and trunnion covers, and the dust collector.

Vacuum out the dust as needed to prevent buildup.

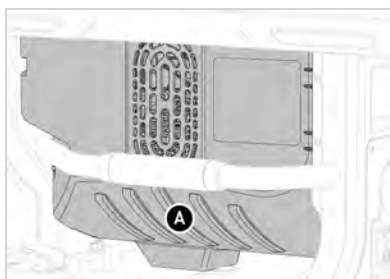

## CLEAN THE DUST COLLECTOR

### **WARNING:**

Always turn off and unplug the saw when working on or maintaining the saw.

Keep the dust collector (A) clean and free of dust and debris. You can use a vacuum to clean out the collector and the internal portions of the saw.

See **HOW TO ATTACH A DUST COLLECTOR** on page 15.

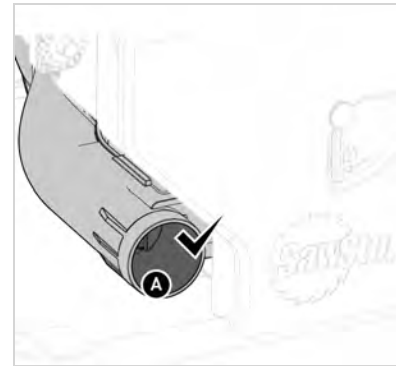

## INSPECT THE POWER CORD

Periodically check the condition of the power cord; if the cord becomes damaged, you must replace it with an original replacement cord available from the online parts store at [SawStop.eu](http://SawStop.eu) or [SawStop.uk](http://SawStop.uk).

The power cord must be replaced by a qualified electrician or authorized service agent. Do not replace the power cord yourself if your saw runs on 230V, 50Hz power.

## INSPECT THE BLADE GUARD

Check the blade guard before each use. Keep the blade guard free of accumulated saw dust, wood chips, and other debris. Check that you have a clear view of the saw blade from all angles; make sure no abrasions or materials on the blade guard obscure your view. Check that the blade guard pivots up and down freely. The blade guard should rest completely on the table when not in use.

## How to Inspect the Side Guards

Confirm the side guards (A) (both sides) swing freely.

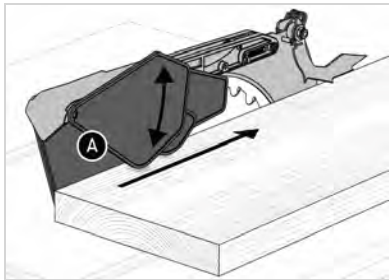

The front side guard should contact (A) the table when you set the bevel of the blade to 45 degrees.

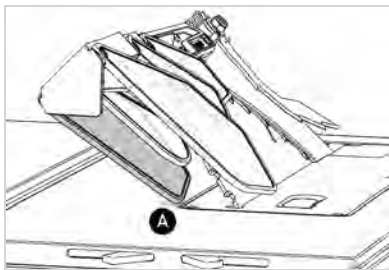

## How to Inspect the Anti-Kickback Pawls

### **i** NOTE:

Anti-Kickback Pawls are an optional accessory available for purchase through the online parts store at [SawStop.eu](http://SawStop.eu) / [SawStop.uk](http://SawStop.uk).

Confirm the anti-kickback pawls engage a workpiece. To test, with the power off and the blade lowered, push a workpiece under a pawl, and then try to pull the workpiece back towards the front of the saw.

The pawl should prevent you from pulling the workpiece. If not, make sure the pawls are correctly installed (see page 13). If installed correctly and the pawls still don't engage the workpiece, replace the pawls.

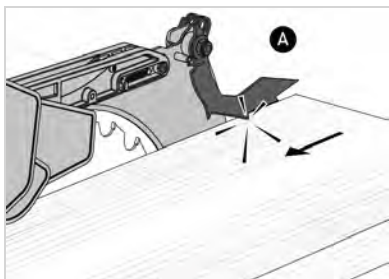

## HOW TO CUT A SLOT IN A REPLACEMENT INSERT

The blade slot in the insert that came with your saw was pre-cut at the factory. For replacement inserts, you must cut the slot. Create the slot using two cuts: one at 90 degrees and one at 45 degrees.

### **!** WARNING:

Do not use a replacement insert without first cutting the slot.

### **!** WARNING:

Always turn off and unplug the saw before working on or maintaining the saw.

1. With the blade lowered, remove the old insert and install the new insert (A).

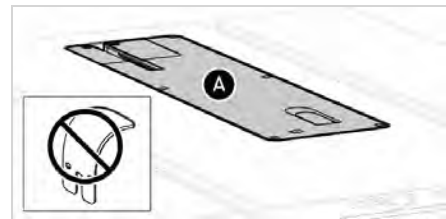

### **!** WARNING:

Make sure the riving knife is not installed when creating the slot.

2. Clamp a board (B) over the insert to make sure the insert remains solidly locked in place while cutting the slot.

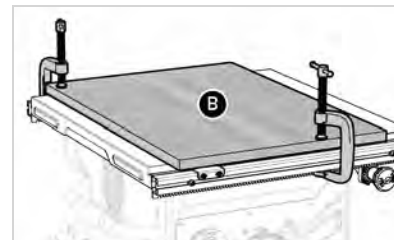

3. Start the motor, and then fully raise the blade (C).

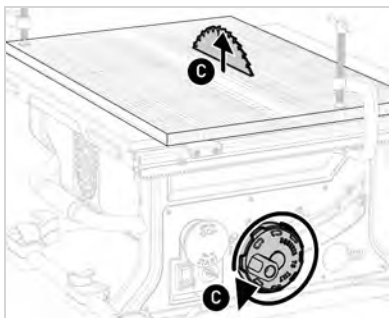

4. Fully lower the blade (D).

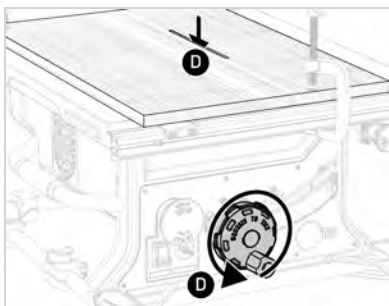

5. Set the bevel to 45 degrees (E).



6. Fully raise the blade (F).

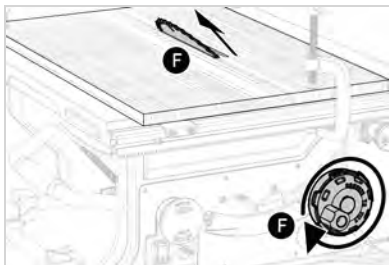

7. Fully lower the blade (G).

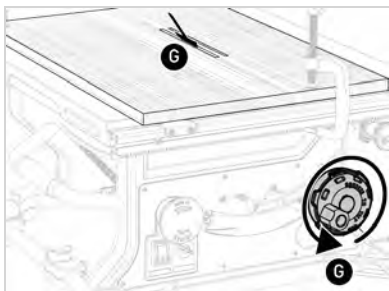

8. Press the Start/Stop paddle (H) and turn off the power switch (I). Wait for the blade to stop spinning.



The slot is cut in the insert.

9. Remove the clamps and board.

## HOW TO ADJUST THE INSERT

The insert is designed to be flush with the table top. If the insert is out of adjustment, it could interfere with the workpiece as you feed the workpiece to the blade. The misalignment could also create an inaccurate or unintentionally angled or beveled cut. Use the following procedure to make sure the top of the insert is flush with the table top.

1. With the blade fully lowered, place a straight-edge (or a workpiece with a true, straight edge) over the insert and table top. Check both the front, middle and rear of the insert.

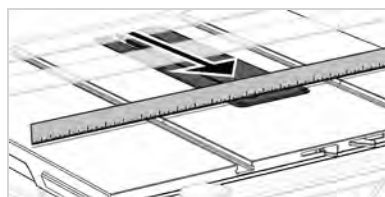

In this example, one end of the insert is above the table top (the misalignment is exaggerated for clarity).

2. Use the 4 mm hex wrench to turn any or all of the six adjustment screws, as needed.

In this example, the screws at the front edge of the insert (A) need to be turned counterclockwise to lower that end of the insert. In this case, both screws were turned an equal amount.

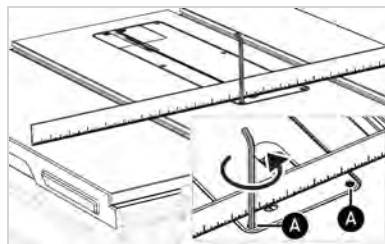

- After adjusting one or more of the screws, check the insert again and adjust the other screws, as needed. Repeat the check and adjust process, as needed, until the insert is flush with the table top.

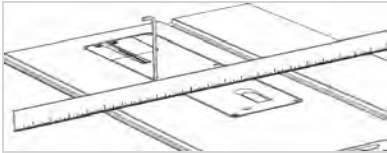

## HOW TO CHANGE THE BLADE



### WARNING:

Wear gloves when handling the blade.



### WARNING:

Always turn off and unplug the saw before working on or maintaining the saw.

#### Tools Needed:

Arbor flange wrench and arbor nut wrench (located on the top of the accessory storage compartment)

#### Instructions:

- Fully raise the blade, and then remove the insert.
- Open the blade guard clamp, and then remove the blade guard or riving knife.
- Use the arbor flange wrench to hold the arbor (A), and the use the arbor nut wrench to loosen the arbor nut (B).

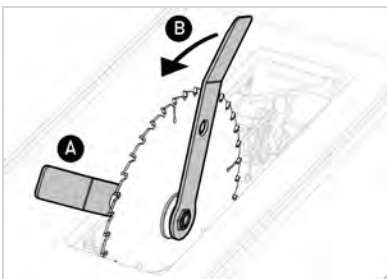

- Remove the nut, arbor washer and blade.

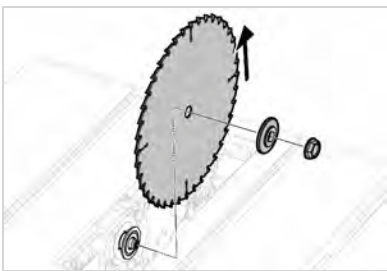

- Install the new blade (C). Install the arbor washer and arbor nut (D). Ensure that the mounting hole of the blade fits over the shoulder of the washer instead of resting on the arbor shaft. Make sure the teeth face in the correct direction, that is, pointing down at the front of the throat (E).

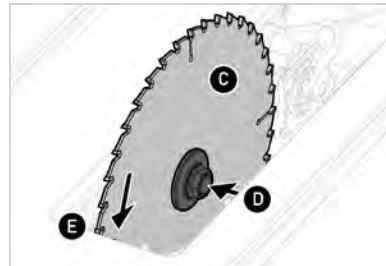

### WARNING:

Make sure the teeth face in the correct direction (pointing counterclockwise when looking from the right side of the saw).

- Tighten the arbor nut. Only a small amount of pressure is needed. Do not over-tighten.

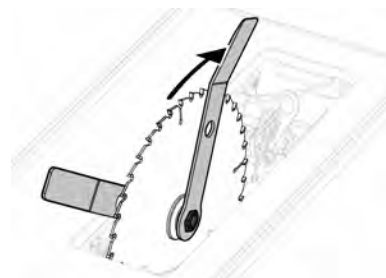

- Install the blade guard or riving knife, and then close the blade guard clamp.



To learn how to check and adjust the alignment of the spreader or riving knife, see page 29.

To learn how to adjust clamping force of the blade guard clamp, see page 29.

8. Install the insert.

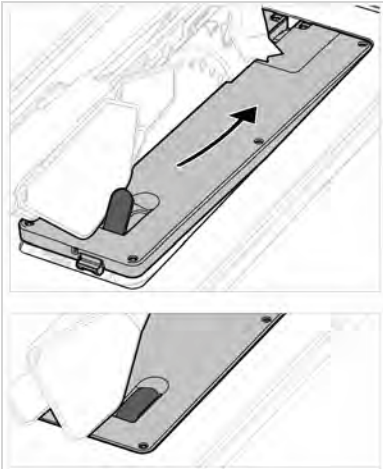

To learn how to adjust blade alignment, see page 27.

## BRAKE CARTRIDGE

Your compact table saw came with a brake cartridge designed to work with a regular 10" (250 or 254mm) blade (see page 4). The brake cartridge contains no serviceable parts—never open the housing of the brake cartridge. Replace the brake cartridge as a unit, as necessary.

Learn more about the SawStop Safety System in the **Safety and General Use Instructions for Portable Table Saws** document included with your saw.

### How to Replace the Brake Cartridge

The following shows how to replace a brake cartridge.



#### WARNING:

Use only the CTS-compatible version TSBC-10R3 of the brake cartridge. (Check the part number and suitability on packaging.) Previous versions of the brake cartridge are not compatible with the Compact Table Saw.



#### WARNING:

Always turn off and unplug the saw before working on or maintaining the saw.

1. Open the dust shroud door: use a flat-blade screwdriver or similar tool to release the latch.



2. With the blade fully raised and the insert removed, pivot the dust shroud door open.

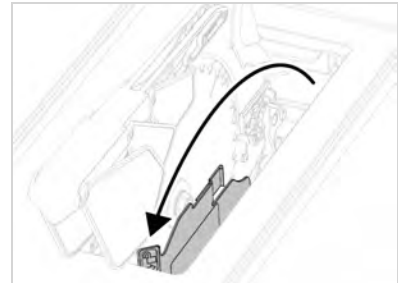

3. Turn the cartridge key 90° clockwise.

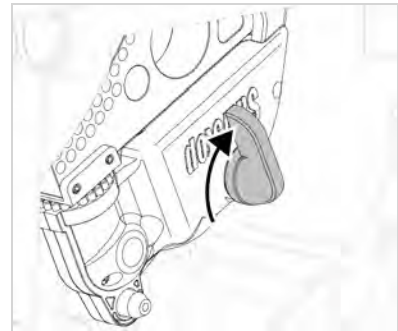

4. Remove the cartridge key.

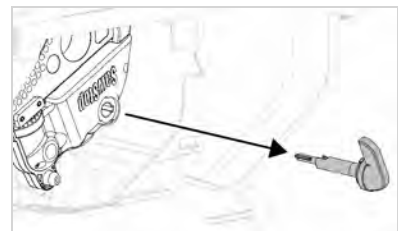

5. Remove the cartridge.

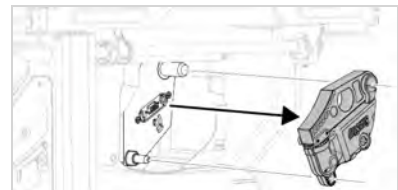

6. Install the new cartridge.

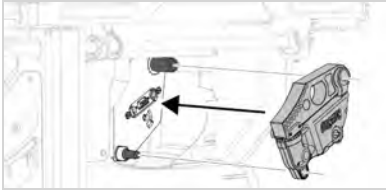

7. Install the cartridge key.

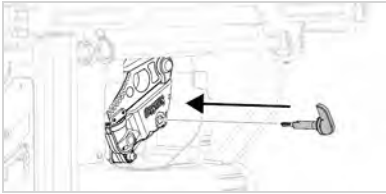

8. Turn the cartridge key 90° counterclockwise to lock.

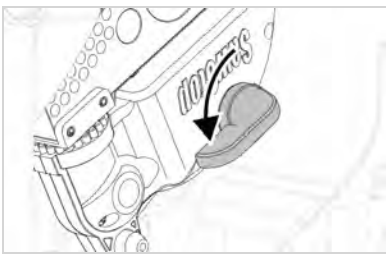

9. Close the cartridge access door.
10. Install the insert and blade guard, or riving knife.

## What to do After a Brake Activation

If you contact the spinning blade, the spring inside the brake cartridge releases and forces the braking pawl into the blade. The blade and cartridge are sacrificed to protect you. This is an activation. This also means you must replace both the cartridge and the blade.



### **WARNING:**

Always turn off and unplug the saw before working on or maintaining the saw.

1. Reset the Retraction of the Arbor Block: During normal use, the arbor block is held in place by a spring-loaded support mechanism called the retraction bracket. When the brake is activated, the angular momentum of the spinning blade is transferred to the arbor block, causing it to drop out of the retraction bracket.

To reset the arbor block into the retraction bracket, fully lower the blade by turning the elevation hand wheel counter-clockwise until the lower elevation limit stop is reached. The arbor block will automatically engage the support mechanism with an audible click. Now turn the elevation hand wheel clockwise to raise the arbor block and blade.

2. Open the brake dust shroud door and remove the cartridge key.
3. Remove the arbor nut and washer. (see page 26)  
Be careful to not drop any parts or tools in the saw. If parts are dropped, you may be able to retrieve them through the dust shroud door or by tipping the saw to allow them to slide out through the dust port. Make sure all parts are fully removed/back in place before starting again.
4. The blade will be embedded in the brake pawl; you will remove the blade and brake cartridge as a unit. Use the blade wrenches as levers to push the blade off the arbor flange and the brake cartridge off the mounting pins. Pry against the blade and cartridge a small amount alternately, in the locations illustrated below.

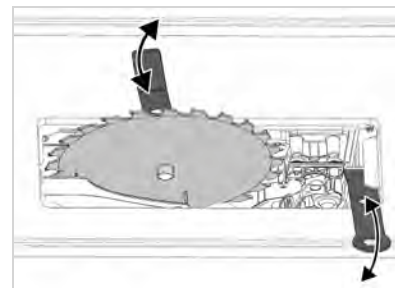

### **WARNING:**

Wear gloves when handling the blade.

5. Lift the blade and brake cartridge from the saw.
6. The forces encountered during activation may have caused your blade to become slightly misaligned. It is recommended to align your blade to the miter slots (see page 27) before using the saw.

Please visit [SawStop.eu/contact](http://SawStop.eu/contact) to provide details of the activation. Your input will be used in our ongoing research and development. You can also send the activated cartridge to SawStop and we will read the data stored in the cartridge. If the data indicate that the activation was caused by skin contact then we will send you a free replacement cartridge.

Use only the CTS-compatible brake cartridge: TSBC-10R3. (Check the part number and suitability on packaging.)

**Previous versions of the brake cartridge are not compatible with the Compact Table Saw.**

## HOW TO ADJUST THE SPREADER OR RIVING KNIFE

The spreader or riving knife mount in the blade guard clamp and help prevent the workpiece from binding on the blade. The alignment of the blade guard clamp is set correctly at the factory but over time, and with usage, the clamp can shift out of alignment. The following instructions show how to check and adjust the clamp and thereby center the spreader or riving knife within the thickness of the blade. The following applies to both the spreader and the riving knife. The riving knife is used in the examples. If you adjust alignment using the riving knife, the spreader will also be centered, and vice versa.

### How to Center Within the Kerf

#### **WARNING:**

Always turn off and unplug the saw before working on or maintaining the saw.

When the blade guard clamp is properly adjusted, the riving knife (A) will be centered within the thickness of the blade. Note that the riving knife is thicker than the blade plate (the body of the blade) (B) but not as thick as the kerf (D).

The kerf is the actual width of the cut zone, as a function of the width of the teeth (C) (see page 4).

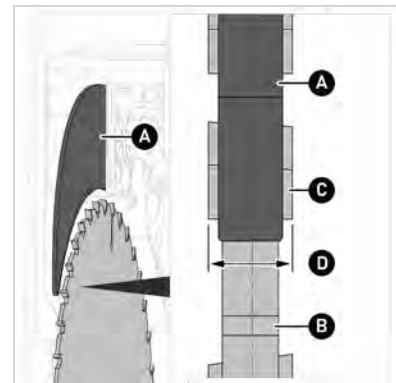

#### Tools needed:

- Feeler gauge
- Straight-edge
- 4 mm hex wrench
- Ideally, use a new blade. At a minimum, make sure the blade is not warped.

#### Instructions:

1. Fully raise the blade, remove the insert and make sure the blade guard clamp (A) is fully closed.

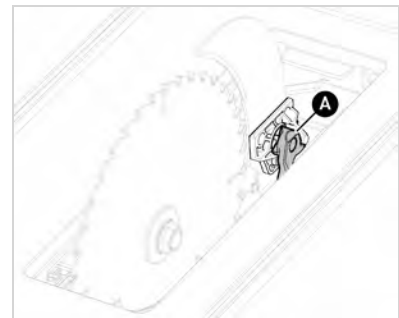

2. Place a straight-edge against the riving knife and along side the blade plate (not against the teeth).

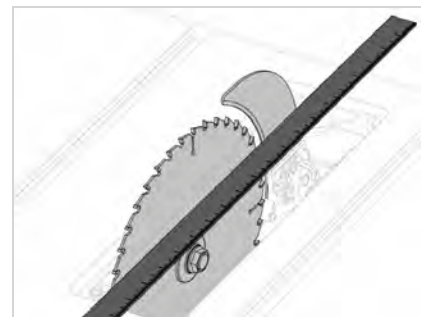

This illustration is as if looking directly down on the table and shows the gap between the straight-edge (A) and the blade plate (B), when the riving knife (C) is centered. The image also shows a tooth on the top of the blade (D) and a tooth on the bottom of the blade (E).

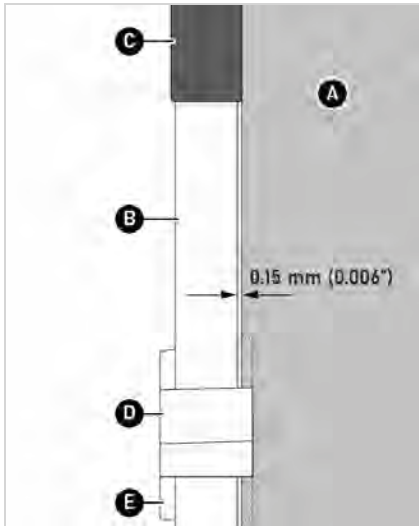

3. To confirm alignment, use the feeler gauge to check the gap between the blade plate and the straight-edge. The gap should be 0.15 mm (0.006"). In this example, the gap is 0.20 mm (0.008"). This means the clamp has shifted to the right.



4. Turn the three clamp mount screws an equal amount to adjust the alignment of the clamp.

In this case, you turn the screws clockwise to shift the clamp to the left.

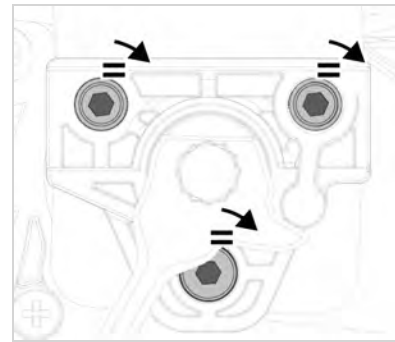

5. For access to the lower screw, open the dust shroud door: use a flat-blade screwdriver or similar tool to release the latch.



6. Pivot the dust shroud door open.

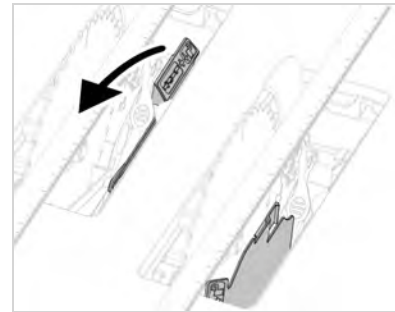

7. Use the included 4 mm hex wrench to turn each screw (A) a small and equal amount clockwise.

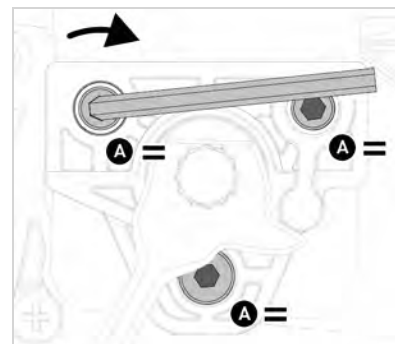

8. Check the gap again. Turn the screws, as needed, until you reach the value of 0.15 mm (0.006"). Take care to turn each screw an equal amount.

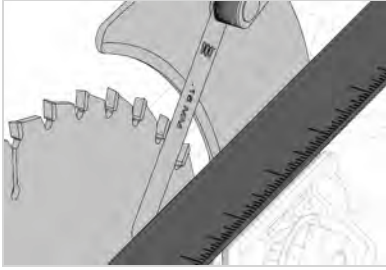

9. Check the gap near the top of the riving knife. Lower the blade until the top of the riving knife is just above the top of the table. Again, make sure the straight-edge is resting against the body of the blade, not the teeth.

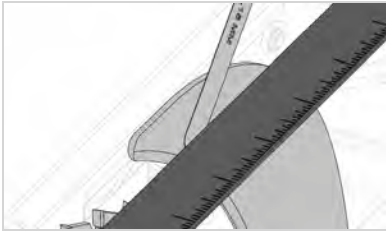

10. When finished, close the dust shroud door and install the insert.

### How to the Adjust Clamping Force

The clamp handle should offer resistance as you rotate the handle down to lock the clamp, and the clamp should hold the spreader or riving knife firmly in place. With the clamp locked, you should not be able to shift the spreader or riving knife vertically within the clamp. At the same time, you should be able to rotate the clamp all the way down into the fully locked position. As needed, use the following procedure to adjust the clamping force.



#### WARNING:

Always turn off and unplug the saw before working on or maintaining the saw.

1. With the elevation set to maximum and the insert removed, open the clamp, and then remove the blade guard or riving knife.



2. Push and hold the clamp handle and the clamp bracket to the left to expose the head (A) of the adjusting bolt.

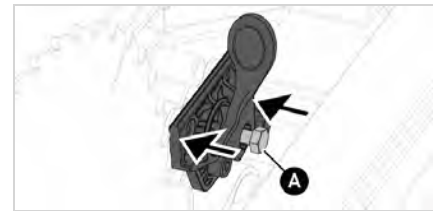

3. If the clamp is too loose, tighten the adjusting bolt slightly by turning the bolt a small amount clockwise. In this example, the bolt is turned just one position relative to the notches in the clamp handle (A) (B).

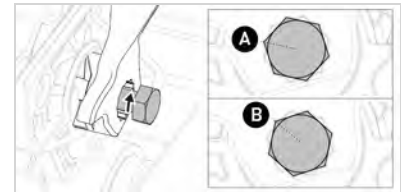

4. Release the clamp so the spring pressure pushes the clamp handle back over the head of the adjusting bolt.



Install the blade guard or riving knife and check the clamping pressure. Adjust again, as needed.

If the clamp pressure is too tight, you will use the preceding steps but turn the adjusting bolt counter-clockwise.

## HOW TO ALIGN THE BLADE TO THE MITER SLOTS

The alignment process consists of two procedures:

- Aligning the blade to the miter slots.
- Aligning the rip fence to the miter slots.

In this procedure, you align the blade to the miter slots. You can perform either procedure before the other—the order does not matter.

### Tools needed:

- Adjustable combination square
- Marker pen
- 10 mm socket or wrench
- 5 mm hex wrench
- Feeler gauge



### WARNING:

Always turn off and unplug the saw before working on or maintaining the saw.

### Instructions:

1. With the blade fully raised and the insert removed, mark one of the teeth at the back of the blade.

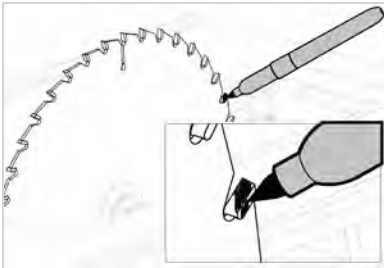

2. Loosen the locking knob on the combination square, and then place the square against the side of the right-hand miter slot near the back of the blade. Align the marked tooth and the end of the ruler.

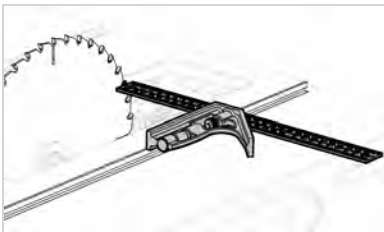

3. Slide the ruler against the side of the marked tooth. Use a light touch, do not deflect the blade.

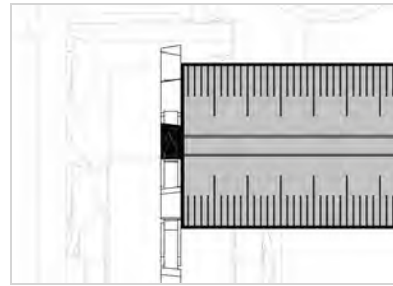

4. Tighten the locking knob on the combination square.

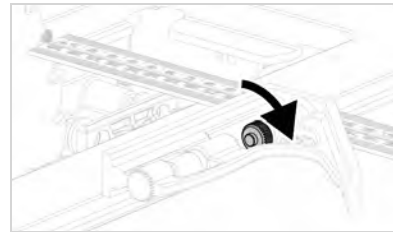

5. Rotate the blade so that the marked tooth is at the front of the blade.

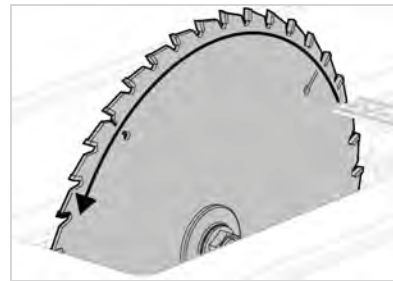

6. Move the combination square so that the end of the ruler aligns with the marked tooth, holding the square firmly against the side of the miter slot.

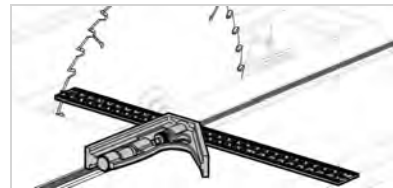

7. If there is a gap, measure the gap with the feeler gauge. If 0.25 mm (0.010") or less, the alignment is within tolerance and no further work is required.

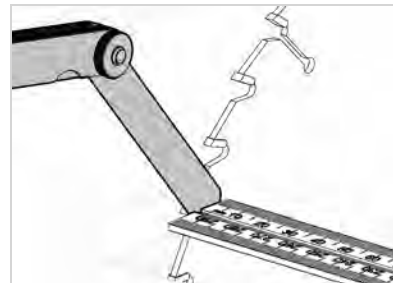

In this example, the gap is larger than 0.25 mm (0.010") and the blade alignment should be adjusted.

Carefully set the square aside.

8. Remove the blade, and then fully lower the elevation mechanism.

Here's how the adjustment mechanism works:

- Turn the alignment adjustment bolt (B), which is threaded through the alignment block (C)
- The alignment block rests against the blade alignment bracket (D)
- Turning the bolt pushes the trunnion assembly right or left, which, in turn, shifts the blade.

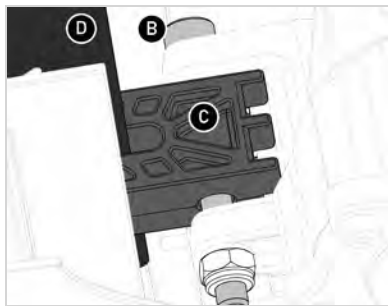

9. Use the 5 mm hex wrench to turn the alignment adjustment bolt a small amount.

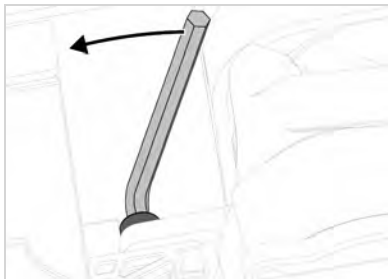

In this example, the bolt is turned clockwise (as if looking from the left side of the saw) to push the trunnion to the right, closing the measured gap.

10. Install the blade, tighten the arbor nut, and then rotate the marked tooth to the front.

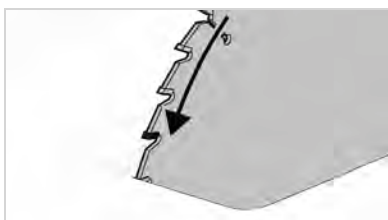

11. Check the gap again. If less than 0.25 mm (0.010"), the blade is aligned. If the gap is still too large, repeat the steps, as needed.

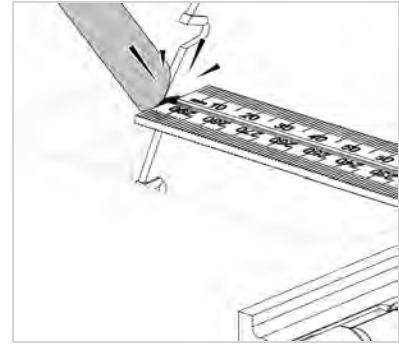

In this example, the gap is completely closed.

## HOW TO ALIGN THE RIP FENCE TO THE MITER SLOTS



### WARNING:

Always turn off and unplug the saw before working on or maintaining the saw.

The alignment process consists of two procedures:

- Aligning the blade to the miter slots (see page 27)
- Aligning the rip fence to the miter slots

In this procedure, you align the rip fence to the miter slots. You can perform either procedure before the other—the order does not matter.

### Tool needed:

- 4 mm hex wrench

### Instructions:

There are three sets of mounting lugs (A) (B) (C) on the front and rear rails. Begin by checking the right-hand lugs (A).

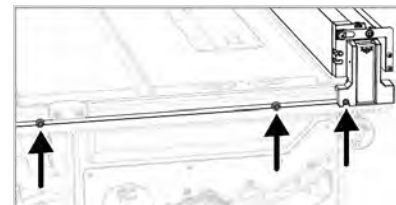

1. Mount the rip fence on the right-hand lugs.
2. Adjust the rip fence until the rip fence is flush with the right-hand face of the miter slot.

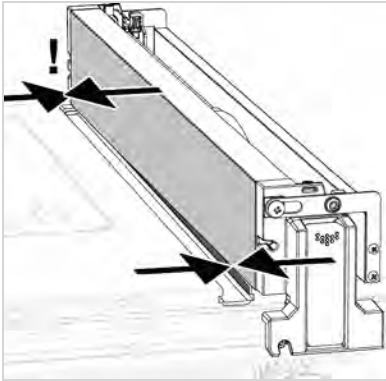

If the rip fence is flush along the entire length of miter slot, the rip fence is aligned to the table and no further work is required for this set of lugs.

In this example, the rip fence is misaligned such that the rip fence at the back of the table is angled in towards the blade.

3. Use the 4 mm hex wrench to loosen the mounting lug on the rear rail.

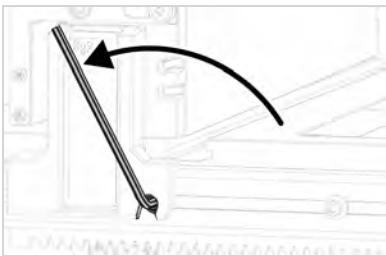

4. Shift the rear of the rip fence and the mounting lug to the left until the rip fence is aligned with the miter slot.

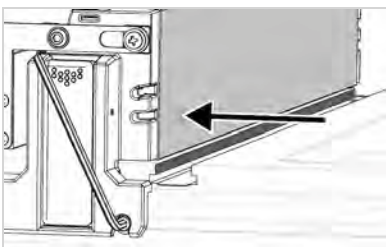

5. Tighten the mounting lug.

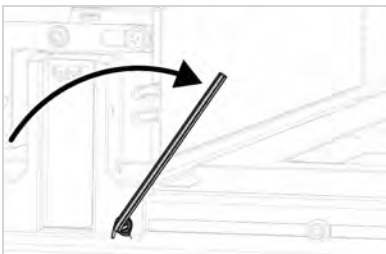

If the rip fence is misaligned in the other direction (the front of the rip fence is closer to the blade), use the previous steps in like manner to correct the misalignment.

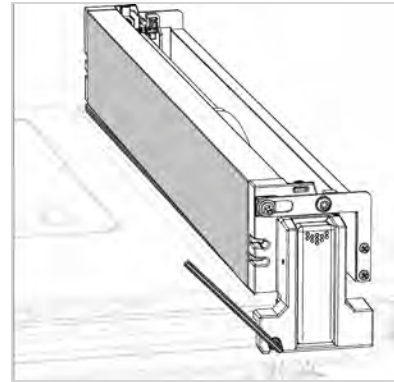

Repeat this process for the other two sets of lugs (B) (C).

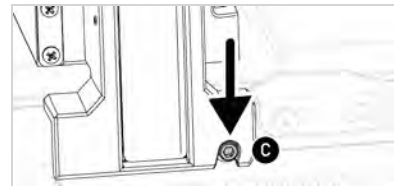
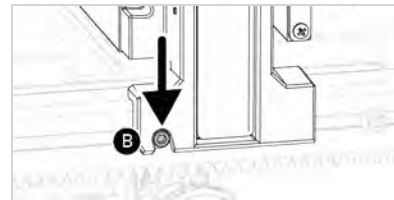

## HOW TO CALIBRATE BEVEL

Use the following procedure to calibrate the blade bevel to the bevel scale. You will make sure the blade is square (90°) with the table top when the bevel is set to 0°, and that the bevel indicator is set to 0°. For best results, first install a new and high-quality blade.



### WARNING:

Always turn off and unplug the saw before working on or maintaining the saw.

1. Set the bevel to  $0^\circ$  (A), and then turn the micro-bevel wheel counterclockwise until you feel a hard stop (B). Push the wheel in to lock the bevel (C).

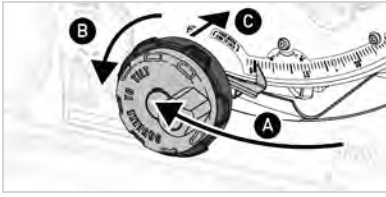

2. Remove the insert and set the blade to maximum elevation.



3. Place a square against the blade body (not against a tooth) and the table top.

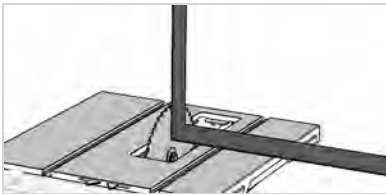

If the blade body is not flush against the square, continue with the following steps. In this example, the blade is tilted to the right (A).

4. Use the 4mm hex wrench to loosen the two bevel-lock nuts (B).

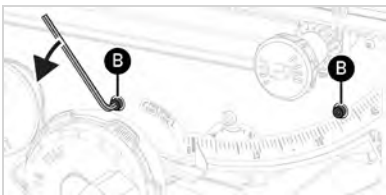

5. Turn the bevel cam clockwise or counterclockwise, as needed, to make the blade flush with the square. In this example, the cam is turned counterclockwise to shift the blade back to the left, perpendicular with the table (C).

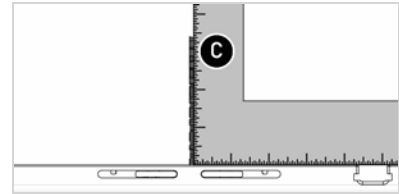

6. Tighten the lock nuts (D).

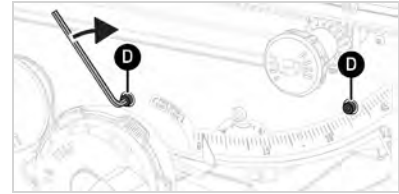

7. Confirm the bevel indicator is pointing to 0. In this example, the indicator is not pointing to 0.

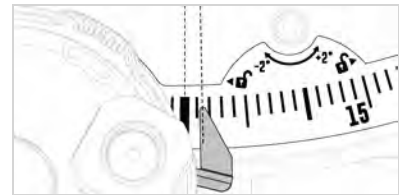

8. Loosen the screw for the indicator.



9. Shift the indicator to align with  $0^\circ$  on the bevel scale.

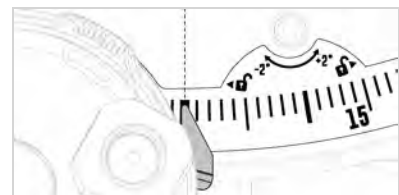

10. Tighten the screw for the indicator.



## HOW TO CALIBRATE THE MITER GAUGE

Confirm that the miter head, or scale, and pointer are correctly aligned with the guide rail of the miter gauge. In the following example, the pointer (A) has been knocked out of alignment, which means that the values on the scale will be incorrect, as referenced to the pointer.

In this case, the scale is set to 90° (B) but the real angle is 89.18° (C) or 90.82° (D).

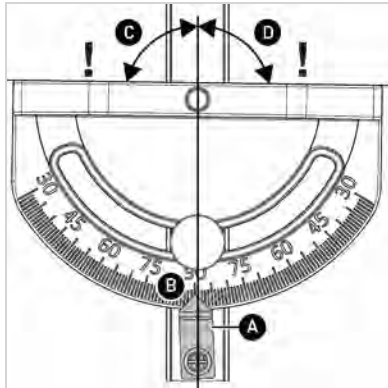

### Tools needed:

- Phillips screwdriver
- Combination square

### Instructions:

1. Loosen the locking knob.

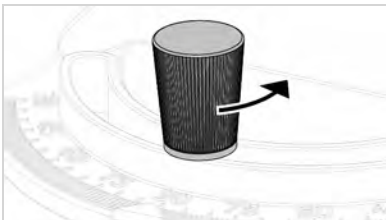

2. Loosen the screw for the pointer.

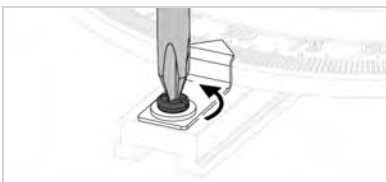

3. Loosen the locking knob on the combination square, slide the ruler so the end of the ruler is flush with bottom face of the anvil (E), and then hold the combination square against the side of the guide rail.

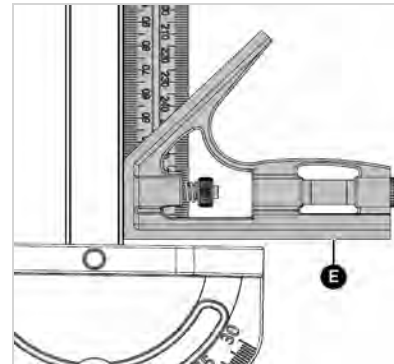

4. Slide the combination square against the miter head, and then pivot the head so it's flat against the anvil.

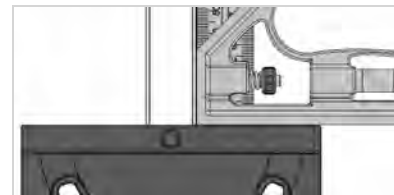

5. While holding the miter gauge and square firmly, tighten the locking knob.

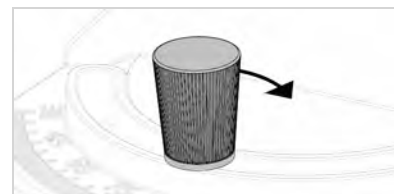

6. Pivot the pointer so that it is aligned with the 90° mark on the miter scale.



7. Hold the pointer firmly, and then tighten the screw.

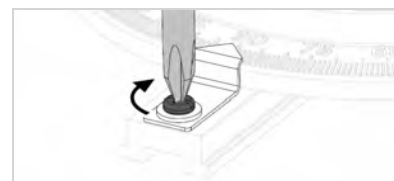

# TROUBLESHOOTING

See the following table for troubleshooting information. If are not able to find a given problem and solution contact SawStop Service (Visit [SawStop.eu/contact](http://SawStop.eu/contact).)

PROBLEM	POSSIBLE CAUSE(S)	RECOMMENDATION
The motor will not start and both status lights on the switch box are off.	There is no power to the saw.	Make sure the electrical supply to the saw is on and that the correct voltage is being supplied.
	There is no brake cartridge installed in the saw.	Install the brake cartridge (see page 27).
	The brake cartridge is faulty.	Replace the brake cartridge with a new cartridge (see page 27).
The motor will not start: the power switch is on, the red status light on solid, the green status light is off.	The brake cartridge is faulty.	Replace the brake cartridge with a new cartridge (see page 27).
The motor starts slowly and/or fails to reach full operating speed.	The electrical supply voltage is too low.	Make sure the correct voltage is being supplied to the saw (see page 5).
The motor stopped unexpectedly during use but the brake did not activate.	The Start/Stop paddle was bumped.	Ensure the Start/Stop paddle is in the OFF position, and then restart the saw.
	The material being cut is overloading the safety detection system (e.g., green or wet wood).	Use a different wood or cut in Bypass Mode (see page 21).
	Electrical power to the system was lost, at least temporarily.	Ensure that the electrical supply to the saw is on and you are using the correct voltage (see page 5).
	The brake cartridge is faulty.	Replace the brake cartridge with a new cartridge (see page 27).
	Loose arbor nut.	Check arbor nut tightness and tighten if necessary.
Cannot turn the saw on in Bypass Mode.	The sequence for starting the saw in Bypass Mode was not completed.	Follow the steps for starting the saw in Bypass Mode (see page 21).

PROBLEM	POSSIBLE CAUSE(S)	RECOMMENDATION
The brake activated, even though there was no accidental contact.	An electrically conductive material contacted the blade, arbor or arbor pulley.	Make sure no metal or other conductive material is touching the blade, arbor or pulley. Use Bypass Mode to cut conductive materials (see page 21).
	The spreader or riving knife came into contact with the blade.	Ensure that the spreader or riving knife is aligned and securely clamped in place. There should be a gap of 4–8 mm between the blade and the spreader or riving knife (see page 4).
	The blade made contact with the brake pawl.	Make sure there is a gap of 1.5 mm to 3 mm between the teeth of the blade and closest point on the brake cartridge. Use only a 10" (254mm) blade (see page 4).
The blade hits the brake pawl during installation.	The blade is the wrong size.	Use only a 10" (254mm) blade (see page 4).
Cannot install the cartridge key.	The key is not rotated properly to align with the keyhole in the cartridge.	Use only a 10" (254mm) blade (see page 4).
	The shaft of the cartridge key is binding in the cartridge or on the cartridge bracket.	Rotate the key so that the handle is pointing directly toward the brake pawl.
Raising or lowering the blade feels or sounds rough.	The alignment block is worn.	Replace the alignment block.
The saw does not make accurate bevel cuts.	The bevel mechanism is not adjusted properly.	Adjust the bevel mechanism (see page 34).
	The bevel angle indicator is not adjusted properly.	Adjust the bevel angle indicator (see page 34).



PROBLEM	POSSIBLE CAUSE(S)	RECOMMENDATION
Cannot remove the brake cartridge.	Retraction mechanism is not reset, blocking access to the brake cartridge.	Reset Retraction Mechanism by fully lowering the blade by turning the elevation wheel counterclockwise until it stops. You should hear the retraction mechanism snap back into the normal operating position.
	The cartridge key is still installed.	Remove the cartridge key.
	The cartridge is bound up on the mounting pins.	Pry the cartridge off the pins with the arbor nut wrench.
Cannot install the brake cartridge.	Retraction mechanism is not reset, blocking access to the brake cartridge.	Reset Retraction Mechanism by fully lowering the blade by turning the elevation wheel counterclockwise until it stops. You should hear the retraction mechanism snap back into the normal operating position.
	The holes in the brake cartridge shell are not aligned with the mounting pins.	Make sure the mounting holes in the brake cartridge are aligned with the mounting pins.
	There is debris on or around the mounting pins, or in the cartridge mounting holes.	Make sure the pins and mounting holes are clean and free of obstructions.
	The blade is interfering with the brake pawl.	Use only a 10" (254mm) blade (see page 4).
Table Insert latch difficult to close.	Worn insert latch.	Use provided 4mm hex wrench to close insert latch.
	Dust and debris in latch.	Remove the single screw holding latch to insert assembly. Remove and clean latch assembly using a light solvent such as isopropyl alcohol. Reinstall latch assembly.